

CENTURION by AmeriWater

Operation & Maintenance Manual



TABLE OF CONTENTS

TABLE OF CONTENTS	1
1 PREFACE	6
2 CONTACT US	7
3 HEALTH AND SAFETY	8
3.1 Explanation of labels	8
3.1.1 Rear panel labels.....	10
3.2 Safety considerations	12
3.3 Intended Use	13
3.4 Operating staff	13
3.5 Residual dangers.....	14
3.6 Handling	14
3.7 Bringing the unit to an immediate STOP	14
3.8 Disposal of device/consumables/replacement parts.....	15
3.8.1 Dealing with leaks from the unit.....	15
3.9 Unauthorized conversion and manufacturing replacement parts	15
3.10 Warranty claims and liability	15
4 ABOUT YOUR CENTURION BY AMERIWATER	16
4.1 General views of the Centurion by AmeriWater unit	16
4.2 Overview	16
4.3 Standard features	16
4.4 Detailed features and process of operation	17
4.5 Explanation of rear connections.....	18
5 INSTALLATION AND COMMISSIONING	19
5.1 Installation & commissioning checklist.....	19
5.1.1 Packing List	19
5.1.2 Installation Kit (RPM00912).....	20
5.2 Environment	20
5.3 Checking water services.....	20
5.4 Checking electrical services	21
5.5 Connection to mains electrical supply	21
5.5.1 Fixed Installation	21
5.5.2 Permanent installation.....	21
5.6 Check default settings	21
5.7 Connection to water services	22
5.7.1 In/Entrée.....	22
5.7.2 Drain	22
5.7.3 Out/Sortié & Return/Retour	22
5.7.4 Acid/Acide	22
5.7.5 Connection to dialysis equipment	23
5.8 Initial start up	23

5.8.1	Initial Start Up from dry Procedure.....	23
5.9	Carry out heat sanitization	24
5.10	Record commissioning performance	24
5.11	Pre-dialysis checks following commissioning	25
5.12	Sample Daily Log Sheet.....	26
5.13	Decommissioning for relocation procedure	27
6	OPERATING THE TOUCHSCREEN	28
6.1	Explanation of buttons	28
6.1.1	Using the touch screen	28
6.1.2	“MENU” button.....	28
6.1.3	“START” button	29
6.2	Operation.....	29
6.2.1	Initial Start-up Procedure	29
6.2.2	Starting the unit	29
6.2.3	Stopping the unit during normal operation	30
6.2.4	Operation of screen buttons	30
6.3	Explanation of the mimic screen	30
6.3.1	Mimic symbols	31
6.3.2	Inlet solenoid.....	31
6.3.3	Mains water break tank.....	31
6.3.4	RO boost pump	32
6.3.5	Reverse Osmosis (RO) module	32
6.3.6	Permeate solenoid	32
6.3.7	Drain Solenoid	32
6.4	Explanation of displayed functions.....	33
7	MENUS AND SETTINGS.....	34
7.1	USER menu.....	34
7.1.1	USER menu screen	34
7.1.2	Set Time and Date	34
7.1.3	Pre Filter replacement date	36
7.1.4	Product Information.....	36
7.2	Engineer Menu	37
7.2.1	Language	37
7.2.2	Units	37
7.2.3	Alarms	37
7.2.4	Maintenance	38
7.2.5	Data logging.....	39
7.2.6	Setup	39
7.3	Settings Menu.....	46
7.4	Menu Structure Diagrams.....	47
7.5	Factory default settings.....	51

8	CHEMICAL CLEANING, HEAT DISINFECTION, AND HEAT DRAW	53
8.1	Explanation – why does the unit require regular cleaning/heat disinfection.	53
8.1.1	Frequency	53
8.1.2	Cleaning/disinfection chemicals	54
8.1.3	Chemical selection guideline	54
8.1.4	Mixing Instructions for Americlean A and Americlean B.....	55
8.2	Chemical cleaning	56
8.2.1	Chemical clean sequence	57
8.3	Interruption to electrical supply during the chemical clean cycle	63
8.4	Heat disinfection	64
8.4.1	Heat disinfection sequence	65
8.5	Heat Draw	69
8.5.1	Heat Draw sequence.....	71
8.6	Sample Port / Quick Disconnection Disinfection Procedure	74
9	MAINTENANCE AND CHECKS.....	75
9.1	Planned routine checks.....	75
9.1.1	Electrical safety inspection and test protocol	75
9.2	Planned preventative maintenance schedule.....	77
9.2.1	Conductivity Calibration	77
9.3	Unplanned minor maintenance and repairs.....	79
9.3.1	Replacement of RO Membrane	79
9.3.2	Replacement of RO boost pump	81
9.3.3	Replacement of inlet solenoid (S1)	82
9.3.4	Replacement of drain valve solenoids #1 (S4) & #2 (S5))	83
9.3.5	Replacement of the chemical draw valve (S3).....	85
9.3.6	Replacement of the permeate valve (S2).....	86
9.3.7	Replacement of the blend valve (S7).....	87
9.3.8	Replacement of the equalize valve (S6)	88
9.3.9	Replacement of the turbine flow sensor	88
9.3.10	Replacement of Internal electrical box fuses.....	89
9.3.11	Replacement of the external fuses.....	90
9.3.12	Replacing the main PCB lithium battery	91
9.3.13	Uploading new software	92
9.3.14	Removing and replacing the main lead	94
9.4	Location of spare parts	95
9.5	Replacement of consumables.....	97
9.5.1	Removal and replacement of the Ultra-filter	97
9.5.2	Consumable replacement frequency.....	98
9.6	Pre-Dialysis checks.....	98
9.7	Cleaning external surfaces	99

9.8	Storage and preservation recommendations	100
10.0	TROUBLESHOOTING	101
10.1	Troubleshooting Guide	102
10.1.1	Warning & alarm messages (Processing Mode)	102
10.1.2	Electrical & mechanical faults.....	109
10.1.3	Water quality non-compliance	111
10.2	Safety features and alarms.....	112
10.2.1	Tank low level	112
10.2.2	Service due.....	112
10.2.3	Poor Permeate Quality	113
10.2.4	High pump pressure.....	113
10.2.5	Low pump pressure.....	114
10.2.6	Permeate line cell error	114
10.2.7	Temperature high	114
10.2.8	Temperature sensor error	114
10.2.9	Level switch error.....	114
10.2.10	Leak.....	114
10.2.11	Tilt.....	114
10.3	Processing modes.....	115
10.3.1	External Standby	115
10.3.2	Power On /Timed standby.....	115
11	CONSUMABLES AND SPARES.....	116
11.1	Consumables	116
11.2	Recommended spares list	116
11.2.1	Minor spares listing	116
11.2.2	Major spares listing	117
11.3	Centurion by AmeriWater Exploded Diagrams.....	118
11.3.1	Break Tank Detail.....	118
11.3.2	Heater Tank Detail	119
11.3.3	Pump Side Plumbing Detail.....	120
11.3.4	Membrane Assembly Detail	121
11.3.5	Rear Bulkhead Detail	122
11.3.6	Right Hand Side Detail.....	123
11.3.7	Side Panel Detail	124
11.3.8	Control Panel Detail.....	125
11.3.9	Touch Screen Detail.....	126
11.3.10	S3 & S6 Detail	127
12	TECHNICAL SPECIFICATIONS	128
12.1	Technical specification	128
12.1.1	Electrical specifications/connections.....	128
12.1.2	Fuse rating/type	128
12.1.3	Main PCB battery specification	128

12.1.4	IP Rating	128
12.1.5	Water quality and performance.....	129
12.1.6	Feed water requirements	129
12.1.7	Water services connections.....	129
12.1.8	Raw water break tank.....	129
12.1.9	Weights and dimensions.....	129
12.1.10	USB mass storage device	129
12.2	Environmental data	130
12.3	Guidance on electromagnetic emissions.....	130
12.4	Guidance on electromagnetic immunity	131
12.5	Guidance on electromagnetic immunity for non-life supporting equipment	132
12.6	Separation distances for RF devices and Centurion	133
12.7	Classification and standards applied	133
13	UNIT OPERATING VALUES	134
14	APPENDIX	135
14.1	How to use the push-fit connectors	135
14.2	E-Waste.....	136
14.3	Circuit board connection schedule.....	137
14.4	Flow Schematic.....	139
14.5	Electrical Schematic	140
	CALIFORNIA PROPOSITION 65.....	141

1 PREFACE

Note: The **Centurion by AmeriWater** is an accessory in a **Medical Electrical (ME) System** in which the dialysis equipment comprises the **Medical Electrical Equipment**.

This **Operation & Maintenance Manual** provides all of the information and instructions needed for trained renal technicians to perform basic service and maintenance on the **Centurion by AmeriWater** single patient reverse osmosis unit.

Please read the instructions carefully and make sure that you fully understand the information given before carrying out any servicing or repairs.

Details on how to install & commission the **Centurion by AmeriWater** can be found in the **Installation & Commissioning Guide**. Installation of the unit would always be carried out by your Healthcare provider or an approved trained technician.

Once trained and approved to do so by your Healthcare provider a detail step by step guide on how to chemically clean, carry out routine heat disinfection, and heat draw cycles can found in the **Chemical Cleaning, Heat Disinfection, & Heat Draw Instructions** document.

For users of the unit (Home patients) an **Operating Manual** details in simple terms how to operate the unit for home dialysis.



Warning: Before operating the unit always check to see that the water and electrical connections are secure and not likely to cause a trip hazard.



Warning: This Reverse Osmosis System (RO) contains a preservative solution to prevent microbiological growth and freezing. Discard all product water for at least two hours of operation before placing the RO in service.



Warning: The AmeriWater Centurion 1500+ Reverse Osmosis Systems are water treatment systems intended for single patient use in hemodialysis applications. As such, the Centurion is intended to be turned off between patient treatments. Turning off the Centurion between patient treatments allows heat and electrical energy to dissipate from the system. Failure to turn off the Centurion between patient treatments may result in electrical energy and heat build-up in the system, which may result in erratic operation.

2 CONTACT US

Should you require any additional information relating to the servicing, maintenance, spares and consumables, contact **AmeriWater** or refer to guides detailed in Section 1 PREFACE.

AmeriWater: Tel No. 800-535-5585

(Or your local authorized **AmeriWater** distributor)

Useful Telephone Nos.

Distributor:

Tel No.....Contact Name:.....

Tel No.....Contact Name:.....

3 HEALTH AND SAFETY

CAUTION: Explanation of expressions



WARNING

This symbol is used to alert the user not to take a certain action, which if taken could cause a potential hazard and result in a serious adverse reaction, injury or even death. The warning symbol may also be used to alert the user to take a certain action to avoid a potential hazard. In all cases within this document, where this symbol is used it is important that you familiarise yourself with the nature of the potential HAZARD and any action that needs to be taken.

Note:

A reminder or useful information that can be used to help explain a command or action or give guidance

3.1 Explanation of labels

There are a number of labels applied to the outside of the *Centurion by AmeriWater* unit which identify hazards, advise caution or instruct the user to seek reference before proceeding with an action. These are identified below.



No Pushing: The unit has been designed as a stationary device during normal operation. Do not push the unit when in operation as this may cause the integral tilt detector to shut the unit down.



Refer to Manual: is used when reference should be made to the manual to obtain advice and or information before carrying out a task. Please read the information given in the operating instructions carefully before proceeding. If in doubt contact, **AmeriWater** for advice and assistance.

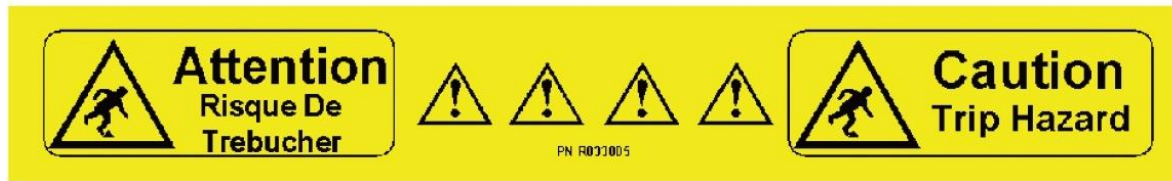

Trip Hazard: there are a number of water and electrical connections from the rear of the unit to the renal replacement equipment and general services. To warn anyone from inadvertently tripping over these service lines a Trip Hazard label is used as a visual warning.



Hot Surface: This label is used to indicate that the surface labelled may be hot to touch under certain circumstances during the operation of the unit and in particular during the heat disinfection cycle. Avoid handling any part with this label during heat disinfection or take suitable measures to protect yourself from the heat.



DO NOT SIT: Under no circumstances should the unit be sat on or objects placed on the top sloping cover as the stability of the unit may be affected.



DO NOT STEP: The unit should under no circumstances be stood upon or used as step.

Note: The *Centurion by AmeriWater* unit is supplied with several detachable parts. Only use those parts that are identified with the following labels. **DO NOT** use alternative parts or this may invalidate the warranty or compromise the performance of the unit. Refer to **Section 3.9** “**Unauthorized conversion and manufacturing replacement parts**”

3.1.1 Rear panel labels

**DO NOT OBSTRUCT
NE PAS COUVRIR**

Placed above the main cooling fan, the label is used to warn users not to cover the vent.

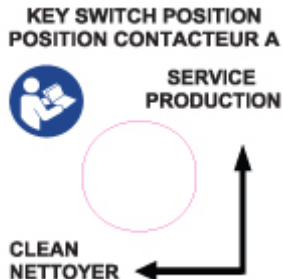

For safety a key is provided to operate the unit and prevent the unit accidentally being placed into a clean. This label identifies the position of the key. When approved/trained to do so always refer to the “**Chemical cleaning and heat disinfection Instructions**” found in **Section 8** if unsure about when and how to use this key.



External alarm is not used on the 00MROC-2 Centurion by AmeriWater



The black cap provides protection of the USB outlet used for essential programming and downloading of recorded data. **DO NOT** remove the cap during normal operation or connect to any external device or mass storage device not specified within this manual. Refer to **Section 12.1.10** for detail of compatible mass storage devices.

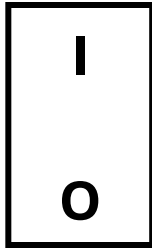

Mains On/Off isolating switch

I = Power **On**

O = Power **Off**

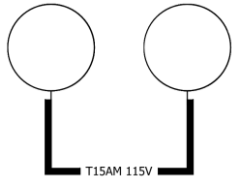

This label identifies the position of the unit's two external fuses. Refer to **Section 12.1.2** for Fuse details and **Section 9.3.11** for replacement instructions.

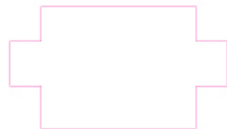

The supply mains electrical power lead is plugged in at this point. The label gives details of the electrical supply rating suitable to operate the unit. See **Section 12.1.1** and **Section 9.3.14** for replacement instructions.



115V 60Hz 15A



This label provides details of all the water connections. The “Refer to manual” symbol advises anyone connecting or disconnecting the water lines to refer to the relevant **Installation and Commissioning guide** for more details.

ACID/ACIDE	Cleaning chemical injection port.
IN/ENTRÉE	Main feedwater connection.
OUT/SORTIÈ	Purified water outlet to dialysis machine.
RETURN/RETOUR	Purified water return from dialysis machine.
DRAIN/DRAIN	Waste water from unit to be connected to drain.

3.2 Safety considerations

Requirements, standards and regulations specific to the country in which the unit is used must be observed. Contact the local regulatory body for confirmation of these regulations and standards.

CAUTION: When used as a medical device Federal Law restricts this device to sale by or on the order of a physician as per 21CFR 801.109(b)(1).

**Warning:**

- The unit is not for use in explosive or oxygen rich atmospheres.
- The unit is for indoor use only and must not be washed down.
- The unit must not be allowed to freeze or be stored at temperatures below 41°F or above 158°F.
- Always operate in a well ventilated area and ensure the cooling fan vents are not covered.
- **DO NOT** sit on the unit, place items on top of it or use it as a step. Always operate the unit on a firm and level surface.
- **DO NOT DRINK** the purified water produced by the unit; it should only be used for the purposes intended as stated in **Section 3.3“Intended Use”**
- Do not sit on the unit, place items on top of it and always operate on a firm and level surface.
- On no account must the unit be connected to the electrical supply when the side panels have been removed unless you have been trained to service or repair the unit.
- If the unit’s performance becomes impaired and any remedial work is outside the scope of this manual, do not operate the unit and seek advice from **AmeriWater**.
- The unit must only be service and maintained by **AmeriWater** or by suitably trained/authorized technician.
- Failure to observe the instructions contained in this manual may compromise the safety, performance and reliability of the unit and may void any warranties.
- The unit must only be use in accordance with its “**Intended Use**” to feed hemodialysis equipment as specified in **Section 3.3**



Warning: This Reverse Osmosis System (RO) contains a preservative solution to prevent microbiological growth and freezing. Discard all product water for at least **two hours** of operation before placing the RO in service.

**Note:**

- It is possible that equipment/devices located in close proximity to the RO unit may affect the operation of the unit due to emitted electromagnetic radiations or other interferences. If this is so relocate the relevant equipment away from the unit. Refer to **Section 12.6**.
- Care must be taken not to place near the RO unit any source of RFI/EMI, which is liable to cause electromagnetic disturbance. If the RO is affected by such disturbance, the source must be suppressed or moved.

3.3 Intended Use

The AmeriWater **Centurion by AmeriWater** Reverse Osmosis Systems are water treatment systems intended for use in hemodialysis applications. They are designed to pre-treat and purify potable water for use in making dialysate for hemodialysis and to meet current AAMI and Federal (U.S.) standards. The device is intended to be a component in a complete water purification system, and is not a complete water treatment system. It must be preceded by pre-treatment devices, and may need to be followed by post-treatment devices as well to meet current AAMI and Federal (U.S.) standards. The Centurion by AmeriWater Reverse Osmosis System is intended for use in a hospital, clinic, dialysis center, or for home care for single patient use. The device includes an integrated heat sanitization process.

The **Centurion by AmeriWater** unit is a **Class III (Health Canada) / Class II (USA) Medical Device** intended for use in hemodialysis applications. It should only be used to feed hemodialysis equipment that complies with the current IEC 60601-2-16 standard.

The unit has been designed to pre-treat and purify potable water for use in the preparation of dialysate solution suitable for hemodialysis and related therapies in accordance with current **AAMI/ANSI/ISO** and Federal (US and Canadian) standards.

The **Centurion by AmeriWater** unit is intended as a stationary device for indoor use only in hospitals, clinics, dialysis centres or for home care for single patient use as part of a **Medical Electrical (ME) system**. The unit should not be stacked on top off or placed directly adjacent to other electrical/electronic equipment.

The **Centurion by AmeriWater** water purifier works on the principle of reverse osmosis and Ultra-filtration to provide purified water suitable for both hemodialysis and Hemodiafiltration and has been designed for continuous operation.

3.4 Operating staff

**Warning:**

The unit must only be operated/serviced/maintained and installed by persons who have been suitably trained and have studied the instructions within this manual and supporting documents and who are familiar and confident with the operation of the unit.

Service and maintenance of the unit is limited to authorized and trained technicians approved by **AmeriWater** or their appointed distributor.

It is essential that in the event of an emergency the location of the Circuit Breaker or other isolation device protecting the equipment is known and that the mains plug is accessible at all times as this can be used as a method of isolation.

If at any time you are unsure about the electrical safety of the unit or have reason to believe that it is potentially unsafe to use you should switch the unit off and isolate the unit at the Circuit Breaker.

3.5 Residual dangers

**Warning:****Electrical Shock.**

With the side covers removed for servicing or maintenance activities take necessary precautions to avoid electrical shock.

Mechanical force.

With the side covers removed and under normal operating conditions some parts of the system can be under pressure of up to 215 psi (15 bar).

Hot Surfaces. During the heat disinfection/draw cycle some of the internal and external surfaces/components/pipework will become hot to touch.

3.6 Handling

**Warning:**

The unit has been specifically designed as a stationary device. Should the unit need to be relocated it must be decommissioned before moving. Refer to **Section 5.12 “Decommissioning for relocation procedure”** in **Installation & Commissioning Guide**. The dry weight of the unit is 86 pounds. A transport cart or other suitable device should be used when moving the unit. Precautions should be taken to secure the unit from toppling during relocation.

Do Not pick the unit up by the side covers; they are not designed to take the weight of the unit. Support the unit by holding the underside of the chassis while steadying the body.

When relocating the unit always ensure the unit has performed its full drain down routine. To do this switch the unit on, isolate the incoming mains water supply, press **“START”** and run the unit until it stops due to **‘Low Tank Level’** then switch off.

Do Not move the unit while it is still in operation.

3.7 Bringing the unit to an immediate **STOP**

If you need to stop the unit quickly and immediately at any time, simply press the black rocker switch on the back of the unit. Then as a precaution, it needs to be turned off the water supply. Alternatively press the red **“STOP”** button on the touch-screen twice.

Unless safe to do so **Do Not** restart the unit until you have checked that it is safe to do so. If the original fault that required the unit to be shut down cannot be resolved contact **AmeriWater** for advice or assistance, contact telephone numbers can be found in **Section 2**.

3.8 Disposal of device/consumables/replacement parts

Refer to **Section 14.2** for details regarding disposal of the device, its replacement parts and consumables.

3.8.1 Dealing with leaks from the unit

In the event of a leak from the unit, shut the unit down by following the procedure in **Section 3.7**.

If water has leaked from the unit follow in-house clinical practices that relate to the clearing up of spillages or leaks. If the leak cannot be cleared up immediately as a guide we recommend that the area affected is clearly identified and suitable warning signs erected to warn passers-by of a “potential slip hazard”.

3.9 Unauthorized conversion and manufacturing replacement parts

DO NOT under any circumstance, modify, or replace parts with unauthorized parts on the unit or attempt to change/alter its operation or functionality.

If following replacement with approved parts or following repair the unit still does not function/operate in the correct manner contact **AmeriWater** or their locally approved distributor.



Warning:

The **Centurion by AmeriWater** unit should only be used in accordance with its intended use and should be maintained and operated according to the instructions contained within this Operation manual. **AmeriWater** will not accept any responsibility for any damage or injury resulting from improper use, maintenance, unauthorised repair or use of any un-approved parts.

3.10 Warranty claims and liability

This product is covered under the standard AmeriWater warranty policy. For specific terms and conditions, please contact your AmeriWater Sales Representative.

4 ABOUT YOUR CENTURION BY AMERIWATER

4.1 General views of the Centurion by AmeriWater unit



Side view



Front view



Rear view

4.2 Overview

The **Centurion by AmeriWater** water purification unit has been specifically designed as a single patient, reverse osmosis (RO) unit to supply purified water suitable for hemodialysis or renal replacement therapies.

The unit is capable of producing purified water up to 0.40 GPM (1.5 litres per minute) based on a feedwater supply at 50°F.

The unit is fitted with an internal pump that pressurises the water supply and forces it through a membrane which then separates out all of the impurities from the feedwater. Purified water passing through the membrane, termed “permeate”, goes to the dialysis machine and the rejected impurities are flushed to drain.

4.3 Standard features

- Product water output up to 23.7 gallons/hr (0.40 gallons/min)
- Product water exceeding all recognized hemodialysis standards.
- Integrated hot water disinfection up to point of use.
- Integrated hot water disinfection to the hemodialysis machine.
- Multi-colored touch screen display for easy control.
- Instrumentation providing display of water quality, temperature, flow, pressure and salt rejection.
- Quiet running option.
- Audible alarm.
- Data logging facility.
- Internal leak and water loss detection system.
- Recirculation up to point of use.

- Ultra-filter
- Tilt warning detection.
- Built in backflow prevention.
- Semi-automatic chemical cleaning program.

4.4 Detailed features and process of operation

All external water and electrical connections can be found at the back of the unit to reduce the risk of accidental damage.

The feed water enters the unit, passes through the inlet solenoid valve and fills the internal feed water break-tank. The level in the tank is controlled by three level switches, one at high level, one at mid-level and one at low-level. The mid-level switch controls the opening of the inlet solenoid and the high-level switch controls the closing of the inlet valve.

If the feed water stops for whatever reason, or there is insufficient flow, the third bottom level switch turns off the high-pressure Reverse Osmosis (RO) boost pump to protect it from running dry and damaging itself.

The (RO) pump takes water from the internal break tank and boosts the water pressure to the RO membrane. There is a pressure sensor situated immediately after the pump, which will display a warning message on the touch screen, should the maximum system pressure be exceeded.

The pressurized water is forced through the membrane which then separates out up to 98% of the impurities. The purified or "Permeate" water then goes on to feed the dialysis machine. The water containing the rejected impurities is flushed to drain.

The quality, temperature, and flowrate of permeate produced from the RO module is monitored and displayed on the touch screen.

The permeate is further purified by the ultra-filter to reduce the endotoxin level to less than 0.03 EU/ml and a TVC of <0.1cfu/ml.

To ensure the quality of water is maintained every time the unit starts up it carries out a flush to clear the unit of any standing water before producing fresh permeate water.

The microprocessor control system constantly monitors the unit's performance and water quality. If any parameter is exceeded at any time the unit will respond with a warning or advisory message on the touch screen giving advice.

If the unit detects an unsafe condition it will automatically shut down in a safe and controlled manner.

4.5 Explanation of rear connections

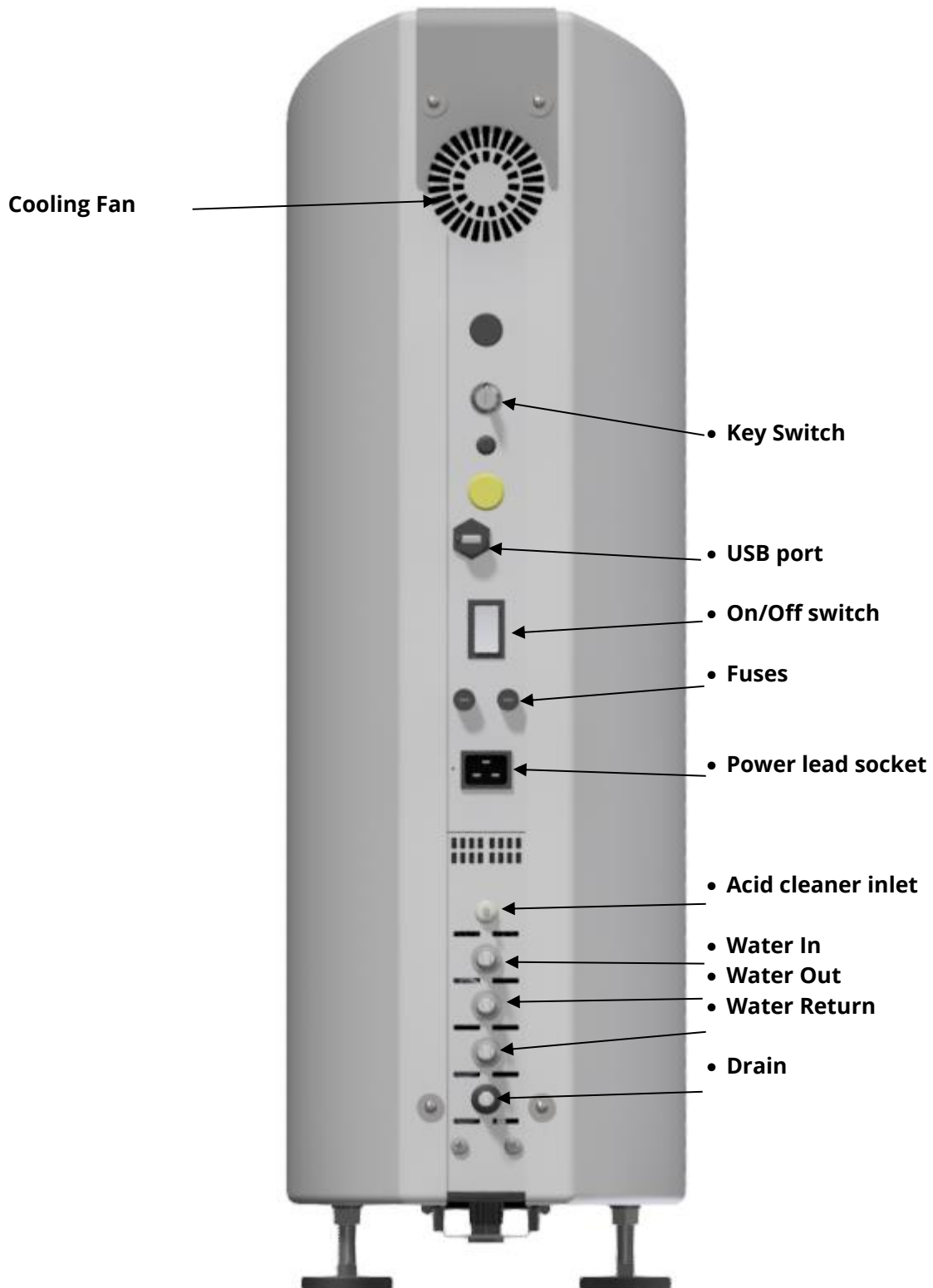

5 INSTALLATION AND COMMISSIONING

5.1 Installation & commissioning checklist

Step	Item	Manual/Section Ref:
1	Check Packing list	Section 5.1.1
3	Check operating environment	Sections 5.2-5.7 and 3.2
4	Check water services	Section 5.3
5	Check electrical services	Section 5.4 & 12.1.1
6	Connections to electrical mains	Section 5.5
7	Check /adjust default settings as required	Section 5.6
8	Set/check time and date	Section 7.1.2
9	Connect water services	Section 5.1.2, 5.3 & 12.1.7
10	Run unit to drain	Section 5.7.2
11	Record performance	Section 5.10 & 13.0
12	Carry out heat disinfection	Section 5.9
13	Electrical safety checks	Section 9.1.1
14	Pre-dialysis checks	Section 5.11
15	Instruction/Training of end user	-

5.1.1 Packing List

Item	Quantity supplied	Notes
Installation Kit	1	See Section 5.1.2
Centurion by AmeriWater	1	-
Distribution Manifold	1	See Section 5.7.5
Lead,mains, C19/US	1	Part no. 66-0181

5.1.2 Installation Kit (RPM00912)

Qty	Item Description
1	½" Hose tail
3	Worm drive clip (8mm)
2	Stainless steel worm drive
0.5m	4mm Nylon tube
3	Hose connector $\frac{5}{16}$ " - $\frac{3}{8}$ "
1m	Braid hose blue ½"
2m	Hose 8mm ID (BLUE)
2m	Hose 8mm ID (BLACK)
1m	Hose Insulation ¾" (BLACK)
1	M8 fibre washer
1	12 x 12 x 0.075 PTFE tape
1	½" x 13mm adaptor
1	12 - 8mm reducer
1	9mm hosetail

5.2 Environment

The unit should be installed, indoors, on a firm, flat level surface in a clean and dry environment. The unit should, be floor mounted and operated in a well ventilated area. Particular attention should be paid to cable management as the unit will require several hydraulic and electrical connections. Refer to **Section 3.2 Safety considerations** and **Sections 5.2– 5.7** for full details of the unit's operating environment.

5.3 Checking water services

Before connecting the unit to the water supply check that the quality meets the requirements as specified in **Section 12.1.6**. The supply should be from a potable water source.

The unit will also require a drain to take the wastewater from the unit. Refer to **Section 12.1.5** for drain water flowrate.



Warning:

You must ensure that the drainage system is capable of handling water that could have a temperature of up to 190 °F.

When the quality of the feedwater supply has been confirmed connect to the unit as detailed in **Section 5.7.1**.

For details of connection to the drain refer to **Section 5.7.2**.

5.4 Checking electrical services

**Warning:**

To reduce the risk of electric shock, this equipment must only be connected to a supply main with protective earth connection.

For permanent installations, the mains supply must be provided with a Branch Circuit Breaker, refer to **Section 5.5.2** for details of rating and specification.

National and local regulations regarding protection against electric shock, electrical overload etc, for the electrical supply must be followed. Where required, appropriate protective devices such as MCCB (Moulded Case Circuit Breakers), Ground Fault Circuit Interrupters (GFCI), Residual Current Devices (RCD, eg. RCCB, RCBO), must be provided by the installer or user. This will equally apply to other devices in the Medical Electrical System, such as the dialysis unit; consult the suppliers' documentation on this subject.

5.5 Connection to mains electrical supply

5.5.1 Fixed Installation

For a **“fixed installation”**, a 115V, 60Hz single phase supply with a protective earth is required. The mains lead supplied in the installation kit (**Part no. 66-0181**) should be used to connect the unit to the wall socket. The socket must be easily accessible and unrestricted to allow isolation of the electricity supply if required.

5.5.2 Permanent installation

For a **“permanent installation”**, a 115V, 60Hz single phase supply with protective earth is required.

The incoming mains supply must be provided with a Branch Circuit Breaker to the following specification:

Rating:	15 amp
Type:	Trip Characteristic C
Specification:	UL 489 or CSA C22.2 No. 5.1

The mains lead supplied in the installation kit must be used. This lead does not have a plug fitted and must be wired into a fused spur socket by a trained/qualified electrical engineer. The on/off rocker switch at the rear of the unit must be easily accessible and unrestricted as it could be used as a method of isolation of the unit.

5.6 Check default settings

Refer to **Section 7.5** for default settings chart.

5.7 Connection to water services

5.7.1 In/Entrée

All the fittings necessary to connect the Centurion to the water supply, dialysis machine and drain can be found in the supplied installation kit,

Using the 8mm ID blue reinforced tubing, fit a 5/16" - 3/8" hose connector to one end of the tubing and secure with a worm drive clip. Push the plain end into the “**In/Entrée**” push fit connection on the rear of the unit; the other end should be connected to the mains water isolation valve (not supplied) and secured with a worm drive clip.

A potable feed water supply is required, terminated with a suitable isolation-valve and ½" hose barb end. A mains pressure exceeding 6 bar (90 psi) should be reduced to 3 bar (45 psi) using a suitable pressure regulator valve (not supplied). The unit will not operate on a pressure below 1.5 bar (22 psi). Refer to **Section 12.1.6** for feedwater requirements.

5.7.2 Drain



Warning:

A suitable, unrestricted, drain is required, capable of handling a flow of at least 2 gallons/ minute and made of material that can tolerate hot water up to 185°F.

Using the 8 mm ID **black** reinforced tubing, fit a 5/16" - 3/8" hose connector to one end and secure with a worm drive clip. Push the plain end into the **Drain** connection at the rear of the unit. Run the pipework to a suitable drain, within 2 metres of the unit ensuring the tubing is unrestricted and runs no higher than 1 metre above the unit.

5.7.3 Out/Sortié & Return/Retour

In this configuration use the doubled up 8 mm “clear” FEP tubing covered with the red heat shrink sleeving (Distribution manifold). At one end, push the tubing into the recirculation manifold assembly connectors. At the other end, connect to the Centurion unit at the “**Out/ Sortié** and **Return/Retour**” ports. The self seal adaptor provides the connection to the dialysis equipment.

5.7.4 Acid/Acide

This port is only used during chemical disinfection of the unit. Only the 4mm clear tubing should be used to connect to this port. Refer to **Section 8 Chemical cleaning and heat disinfection** for details of carrying out a chemical clean.

Cut the clear tubing such that it is able to draw chemical freely from the cleaning solution bottle. At the end that goes into the cleaning solution cut off at a 45° angle.

5.7.5 Connection to dialysis equipment

**Warning:**

Following the rinsing/disinfection procedure the permeate product water should be sampled and the operator satisfied that the water is of the required quality before reconnecting to the dialysis machine.

The distribution manifold should be used to connect directly to the inlet of the Hemodialysis equipment. Use the quick release coupling at the end of the manifold to join to the tubing from the Hemodialysis fitted with the mating half of the coupling.

Note:

It is recommended that the line from the Hemodialysis machine to the coupling be as short as possible to reduce contamination. During heat disinfection the unit will provide hot water right up to the end of the manifold.



Warning: The distribution manifold could if not suitably positioned be a potential trip hazard.

5.8 Initial start up

BEFORE a Centurion unit can be used for the first time, it **MUST** first be purged of any air trapped in the system and then fully rinsed out, in line with the Procedure below.



Warning: This Reverse Osmosis System (RO) contains a preservative solution to prevent microbiological growth and freezing. Discard all product water for at least two hours of operation before placing the RO in service.

Failure to actively rinse preservation chemical from the system will affect the performance of the unit and will result in an alarm condition and may result in patient illness – please ensure that procedure below is followed.

5.8.1 Initial Start Up from dry Procedure

The first time a unit is run it is required to go through a specific process to first remove the air from the system and then rinse out any preservative solution.

The following steps will provide the most efficient method to clear the air from the system.

1. Ensure the unit is connected to the water and electrical services as detailed in **Sections 5.5 & 5.7**
2. Turn on the water supply and check for leaks.

3. Switch on the mains power supply and press the rocker switch on the rear of the unit to the “I” position.
4. Press start on the display (the internal tank will fill and the pump will run.)

NOTE: While the Centurion is purging air from the system the unit may display various alarm/warning messages may be displayed such as ‘low pressure’ and “Permeate line cell error”. The unit may depending on the alarm message may shut down, immediately re-start the unit. This may occur a few times until most of the air is expelled and the system pressure has stabilized and reached the correct level.

5. Run the unit for 2-3 minutes and then turn the water supply off, (keep the unit running). This will drain the internal tank to its lowest position and stop the pump.

With the pump stopped, any air trapped below the membrane will be safely expelled into the now empty tank; some bubbles may be heard escaping.

6. Leave to stand for 1 minute before turning the water supply back on (the unit will restart automatically).
7. Repeat step 5.
8. Turn the water supply on (the unit will restart automatically) and run the unit for 2 hours with product water directed to a drain.
9. The unit should now be purged of any air, and/or preservative solution.
10. Continue to run the unit and enter the performance parameters for the unit into the table in **Section 13** for future reference.
11. When the water quality has been deemed acceptable connect the distribution manifold to the dialysis machine as detailed in **Section 5.7.5**. Before the unit is used carry out the electrical safety test as detailed in **Section 9.1.1**.

5.9 Carry out heat sanitization

(Refer to Heat disinfection instructions located in Section 8.4)

5.10 Record commissioning performance

(Complete **Section 13**)

5.11 Pre-dialysis checks following commissioning

Following any repair/servicing, maintenance or prior to each dialysis session or following storage of the unit it is recommended that the following checks are carried out

- Check that the electrical mains lead is securely clipped in place on the unit and at the wall socket and that the lead is not damaged or likely to cause anyone to trip over it.
- All the water connections are in place, not kinked and show no signs of leaks.
- The “**Blue**” water tubing is connected to the “**In/Entree**” port, the “**Black**” water tubing is connected to the “**Drain**” port.
- The water supply is turned on.
- There are no warning messages displayed on the touch-screen. (Refer to **Section 10.0, “Troubleshooting”** manual, if any alarm or warning messages are displayed.
- The unit should run quietly, if the unit sounds un-usually noisy or you are concerned about its operation refer to the “**Troubleshooting**” Section for guidance.
- The unit has been signed off as electrically safe for use by an approved person.
- The water quality is satisfactory for its intended use to feed hemodialysis equipment.



- **Warning:** The AmeriWater Centurion 1500+ Reverse Osmosis Systems are water treatment systems intended for single patient use in hemodialysis applications. As such, the Centurion is intended to be turned off between patient treatments. Turning off the Centurion between patient treatments allows heat and electrical energy to dissipate from the system. Failure to turn off the Centurion between patient treatments may result in electrical energy and heat build-up in the system, which may result in erratic operation.

5.12 Sample Daily Log Sheet

Equipment Information			
Serial Number:		Date:	

Centurion Cart		
Inlet Pressure Regulator Setting (psi)		≤ 50 psi
Sediment Filter - Differential Pressure (psi)		< 10 psi
Primary Carbon - Differential Pressure (psi)		< 10 psi
Primary Carbon – Effluent Total Chlorine (mg/L)		≤ 0.1 mg/L
Secondary Carbon - Differential Pressure (psi)		< 10 psi
Secondary Carbon – Effluent Total Chlorine (mg/L)		≤ 0.1 mg/L
Check for Leaks		No Leaks

Centurion Heat Disinfection RO Portable		
RO Operating Parameters		
Ultra-Filter Date Replaced (Record Date)		< 26 Heat cycles
Salt Rejection (%)		> 95%
Pump Pressure (psi)		125 – 160 psi
Permeate Quality (µS/cm)		< Alarm set point
Temperature (°F)		55° - 95°F
Feed Quality (µS/cm)		< 2,000 µS/cm
Flow Rate (GPM)		> 0.25 GPM
Last Heat Disinfect Result		Pass
Check for Leaks		No Leaks

Heat Draw		
Last Heat Draw Result		Pass
Check for Leaks		No Leaks

NOTES:

1. Record all log readings while RO is operating and after the RO has been operating for at least 15 minutes.
2. If recorded log readings are outside acceptable parameters, contact clinical engineering for assistance before using.

5.13 Decommissioning for relocation procedure

- Press the “STOP” button and allow the unit to shut down.
- Using the rocker switch located at the rear of the unit switch the unit off and isolate from the mains electrical supply by disconnecting the mains power cord from the wall socket.
- Turn off the water supply.
- Disconnect the distribution loop from the Hemodialysis machine if connected. For convenience the distribution loop can be left connected to the unit as the coupling at the Haemodialysis point is self-sealing.
- Disconnect the tubing from the “In” and “Drain” connections at the rear of the unit. Refer to **Section 14.1** for details on how to remove water connectors.
- Ensure that the outer surfaces of the unit are wiped down with a sanitant before moving, refer to **Section 9.7** “Cleaning of external surfaces” or apply in-house infection control procedures.
- The unit is now ready for relocation, refer to statements regarding moving of the unit in **Section 3.6** “Handling”.

6 OPERATING THE TOUCHSCREEN

6.1 Explanation of buttons

The operation of the *Centurion by AmeriWater* is controlled via the touch screen display which can be found on the top of the unit. The picture below shows an interpretation of the display.

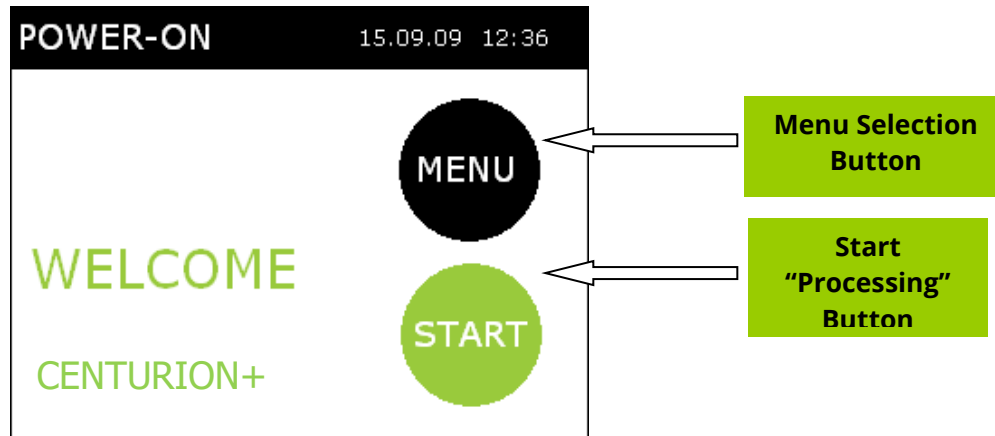

6.1.1 Using the touch screen

In normal operation the screen will display a diagram which mimics the flow path of the water purification along with any messages. **See Section 6.3** for more details.

To select an action simply touch the screen on the appropriate button once with your finger.

Note:

Do Not use sharp or pointed implements, such as pens, pencils etc... to operate the screen as this will damage the sensitive surface of the display, always operate the screen using your fingertips.

Do Not press more than one button at a time.

6.1.2 “MENU” button

Pressing the “MENU” button will bring up the following “USER MENU” screen will appear.

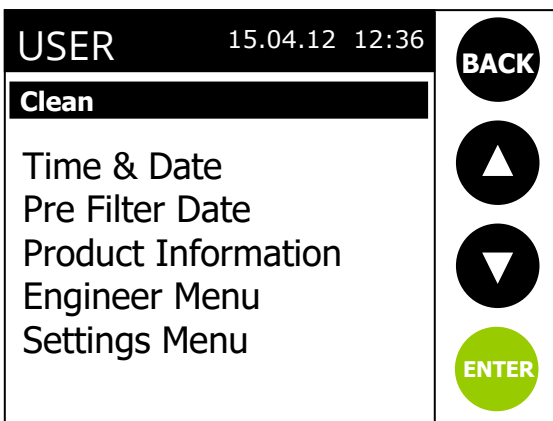

For details on each of the sub-menus and how to access them go to **Section 7**.

6.1.3 "START" button

Pressing the "START" button the unit will go into "PROCESSING" mode and start to produce purified water and the screen below will be displayed.

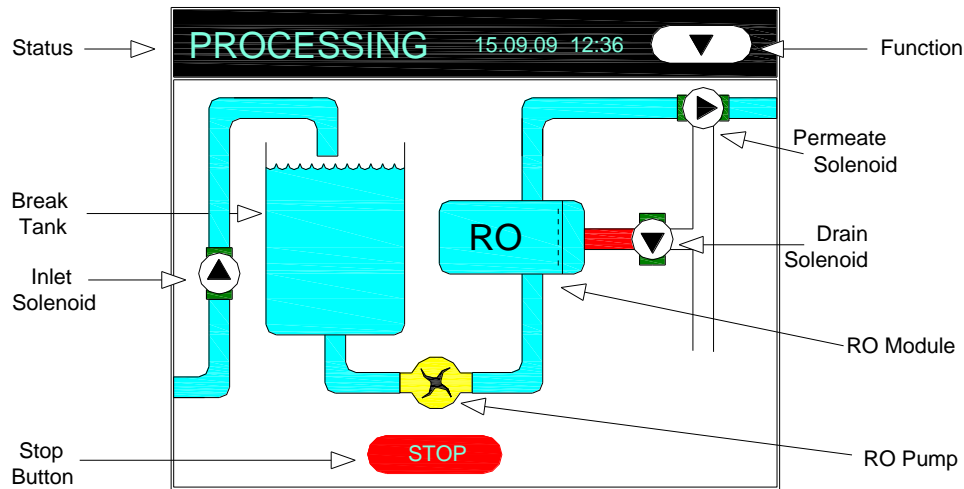

Refer to **Section 6.3** for explanation of the mimic screen symbols.

6.2 Operation

6.2.1 Initial Start-up Procedure

Carryout the Pre-Dialysis checks listed in **Section 9.6**

Once you have completed the above checks switch on the unit using the, **I/O** on/off switch at the rear of the unit. Switch to the "I" position.

When powered the unit's HMI screen will illuminate and display both text and a visual mimic of the units operation.

The touch screen will initially display "Initialization" for a few seconds before showing the **Power On** screen, which displays the current date, time, model type and any active messages.

During "Initialization" the unit will sound two "bleeps" indicating that the audible alarm is functioning.

6.2.2 Starting the unit

To start the unit select the "START" button, the screen will then change to the "PROCESSING" screen which will display a mimic of the unit's operation.

The unit will then carry out a high flow flush to drain, followed by an internal permeate rinse. After 90 seconds, the permeate will automatically flow to the dialysis machine, if connected.

6.2.3 Stopping the unit during normal operation

To stop the unit at any time press the “**STOP**” button on the screen. If the unit has been running for two hours or more, the unit will perform a shut-down flush which directs a high concentrate flow across the membrane to the drain for 30 seconds. After the 30 second shut-down flush the screen will revert to the “**Power On**” display.

During the shut-down flush pressing the “**STOP**” button twice from the processing screen will stop the unit immediately terminating the flush. **(Refer to Section 3.7)**



Warning: The supply mains isolation switch is located at the rear of the unit, ensure that it is accessible at all times and remains clear from obstruction.
Ensure that the wall plug is accessible at all times as this can be used as a method of isolation.

6.2.4 Operation of screen buttons

To access text about the current process, while the mimic screen is displayed, press the function button ▼ at the top right of the screen. This will in turn, display “**Permeate Quality**”, “**Temperature**”, “**Flow Rate**”, “**Pump Pressure**”, “**Feed Quality** and “**Salt Rejection**”.

6.3 Explanation of the mimic screen

This screen is displayed during normal processing.

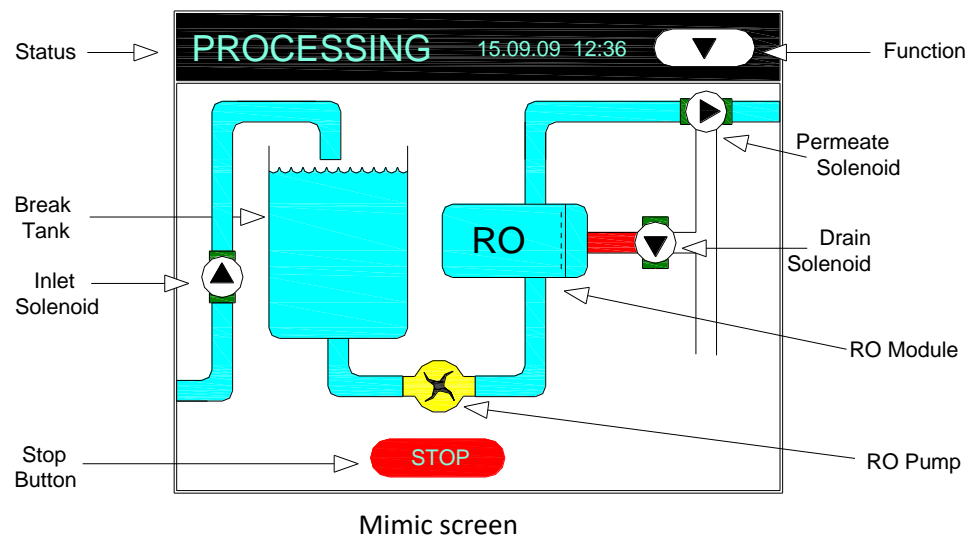

6.3.1 Mimic symbols

The symbols are presented on the screen below the “status bar”. The text indicates the current operation and the stage reached within that operation. This text will alternate with any warning or advisory messages that may be present.

The symbols represent the main components within the unit. Anything coloured red indicates that it is closed or stopped. If the symbol is moving or flashing it indicates it is working.

These symbols are:

- * Inlet solenoid.
- * Mains water break tank/heater tank
- * RO boost pump
- * RO module
- * Permeate solenoid
- * Drain solenoid

6.3.2 Inlet solenoid

The inlet solenoid is a normally closed valve that opens when energised. This is indicated by the black triangle pointing in the flow direction and the blue shading after the valve showing water is flowing.

Water droplets falling into the break tank also indicate that the solenoid is energised and water is flowing through the valve and into the break tank.

6.3.3 Mains water break tank

The water level in the top break tank is monitored by a three float sensor. Four level positions are shown within the tank symbol directly reflecting the sensed level.

- Bottom level
- Low level
- Mid-level
- High level

a) On falling water level:

With the top, mid and bottom switches sensing water the mimic displays high level.
With the mid and bottom switches sensing water the mimic displays high level.
With the bottom switch only sensing water the mimic displays mid-level.
With no switches sensing water the mimic displays bottom level.

b) On rising water level:

With no switches sensing water the mimic displays bottom level.
With the bottom switch sensing water the mimic displays low level.
With the mid and bottom switches sensing water the mimic displays mid-level.
With the top, mid and bottom switches sensing water the mimic displays high level.

c) Level switch fault conditions:

With the top and bottom switches sensing water, but not the mid-level switch, the inlet solenoid is closed and the boost pump stops.

With the mid switch sensing water but not the high or low switches, the inlet solenoid is open and the boost pump is stopped.

If a water level error condition is detected an appropriate error message is displayed (see **Section 10.1.1**).

The error conditions are:

Water sensed on high-level switch only.
Water sensed on mid-level and high-level switches only.
Water sensed on low-level and high-level switches only.
Water sensed on mid-level switch only.

6.3.4 RO boost pump

When the pump is running an animated rotor revolves inside the pump symbol.

6.3.5 Reverse Osmosis (RO) module

A shaded box represents the RO module with the water inlet, drain and permeate connections shown. The box symbol provides no indication of status.

6.3.6 Permeate solenoid

The Permeate solenoid is open when energised. This is indicated by the triangle pointing in the flow direction and blue shading after the valve indicating that water is flowing.

6.3.7 Drain Solenoid

The unit has two Drain solenoids but the display gives a general indication of operation only. The Drain valves open when energise and the black triangle indicates direction of flow and the blue shading after the valve shows that water is flowing.

6.4 Explanation of displayed functions

Each time you press the Function button, ▼, at the top right hand edge of the screen you will be able to display information relating to the performance of the unit. The information will be in the form of numbers and text and displayed on the “status bar”. This information may be required by your Healthcare provider when diagnosing a possible fault.

There are 6 different functions an explanation of each is given in the table below.

Displayed Function	Explanation
Flow Rate	This is the volume of permeate the unit is producing and is measured in “ gallons/min ”
Permeate Quality	This value indicates the quality of the permeate water and is measured in “ microsiemens/cm ” or µS/cm .
Temperature	This tells you the temperature of the water being produced and is displayed in, °F .
Pump Pressure	The unit contains a pump to process the water and this displays the pressure the pump is running at in “ psi ”.
Feed Quality	If enabled the unit will constantly measure the quality of the incoming water supply and display the reading in “microsiemens/cm” or µS/cm .
Salt Rejection	Again if enabled the “ Salt Rejection ” compares the quality of the purified water to the feed water and expresses it as a “%”. This will be used by your Healthcare provider to check the performance of the unit.



Warning:

It is recommended that the key used to select CLEAN:SERVICE positions is removed to prevent anyone from accidentally switching the unit to the wrong mode during use. The key is only required for use during either Heat disinfection or chemical clean. Having the key switch in the wrong position could interrupt dialysis or the cleaning/disinfection of the unit.

7 MENUS AND SETTINGS

7.1 USER menu

Pressing the “**MENU**” button from the **POWER-ON** screen will reveal the “**USER MENU**”. The menu is typically for use by the Patient or Nursing staff.

There are six sub menus which will allow you to start a “**Clean**” (see Section 8), adjust the “**Time & Date**” (see Section 7.1.2), reset the internal Ultra-filter replacement date (see Section 7.1.3), for “**Product Information**” refer to Section 7.1.4. The “**Engineer menu** (Section 7.2) and “**Settings Menu** (Section 7.3), are PIN number protected and should only be accessed by trained/approved personnel.

7.1.1 USER menu screen

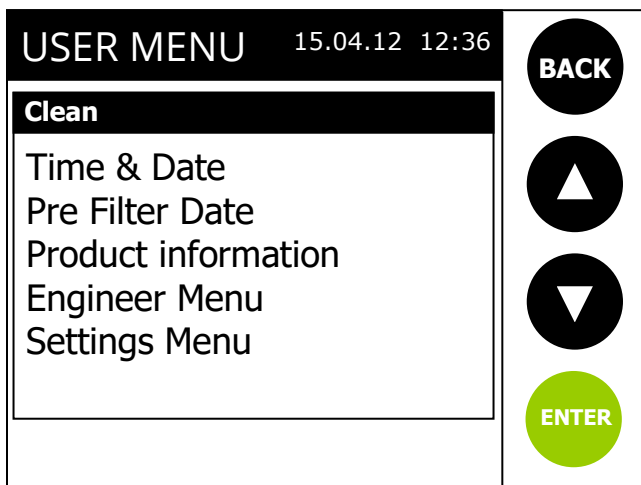

7.1.2 Set Time and Date

From the USER MENU and by using the ▲/▼ buttons select “**Time & Date**”, then press the “**ENTER**” button. The first screen below will be displayed.

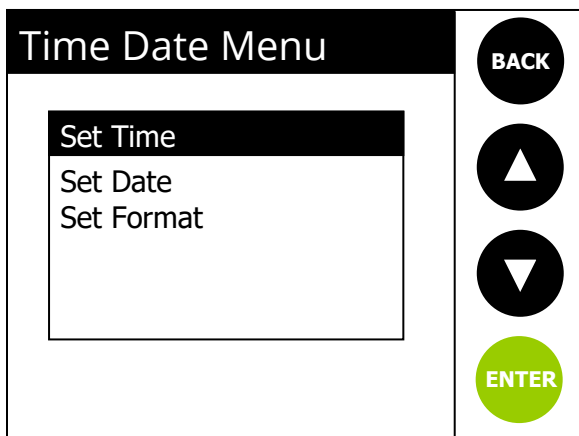

Again by using the ▲/ ▼ buttons select from one of the entries listed and press “**ENTER**”

To return to the main “**USER MENU**” simply press the “**BACK**” button

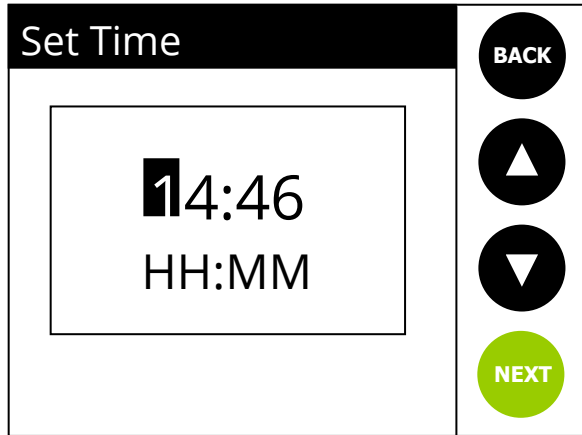

If you select **“Set Time”** the screen opposite will be displayed. The flashing cursor identifies which digit you can adjust.

By using the ▲/▼ buttons you can either increase or decrease the number value. Once the correct number has been selected, press **“NEXT”** to move to the next number. **On pressing “NEXT”** on the final number a confirmation screen will pop up, stating **“Done”** and after a few seconds the screen will revert back to the **“Time Date Menu”**

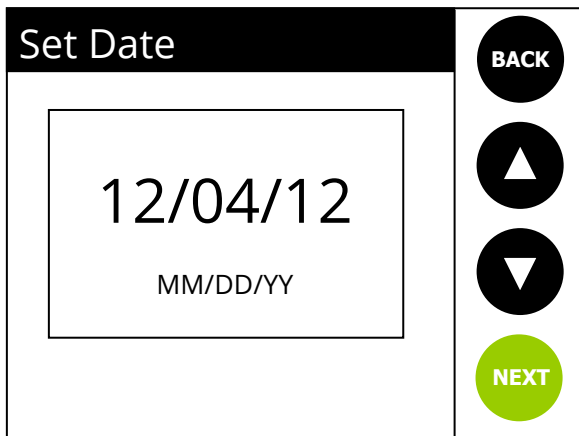

To select **“Set Date”** from the menu use the ▲/▼ buttons and press **“ENTER”**. The date will be displayed and the cursor will flash on the first number.

Use the ▲/▼ buttons to change the number to the correct value, then press **“NEXT”** to move to the next one. On pressing **“NEXT”** on the final number a confirmation screen will pop up and after a few seconds the screen will revert back to the **“Time Date Menu”**

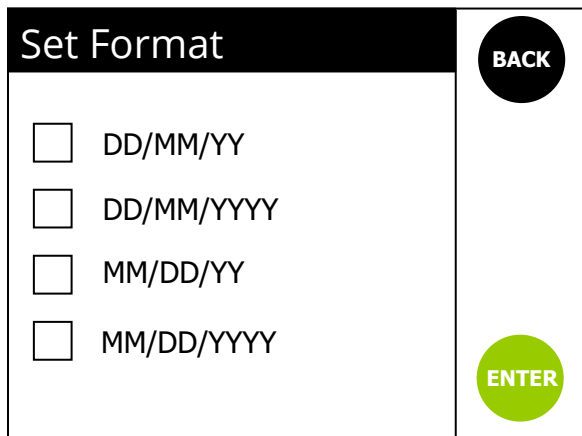

Should the format of the date be wrong, by selecting the **“Set Format”** menu and by pressing **“ENTER”** the **“Set Format”** menu will be displayed. Touch the box that matches the correct format. A tick will appear to confirm your selection. Press **“ENTER”** a confirmation screen will pop up and after a few seconds the screen will revert back to the **“Time Date Menu”**

Note: Pressing the **“BACK”** button prior to pressing the **“ENTER”** button will cancel changes currently being made and return you to the **“USER MENU”**

7.1.3 Pre Filter replacement date

(00MROC-2 Centurion by AmeriWater UF)

The Pre filter replacement date should be reset when the Ultra-filter is replaced during maintenance. This would normally be carried out by your Healthcare provider and will ensure that the Centurion unit will provide a prompt message when the next filter change becomes due.

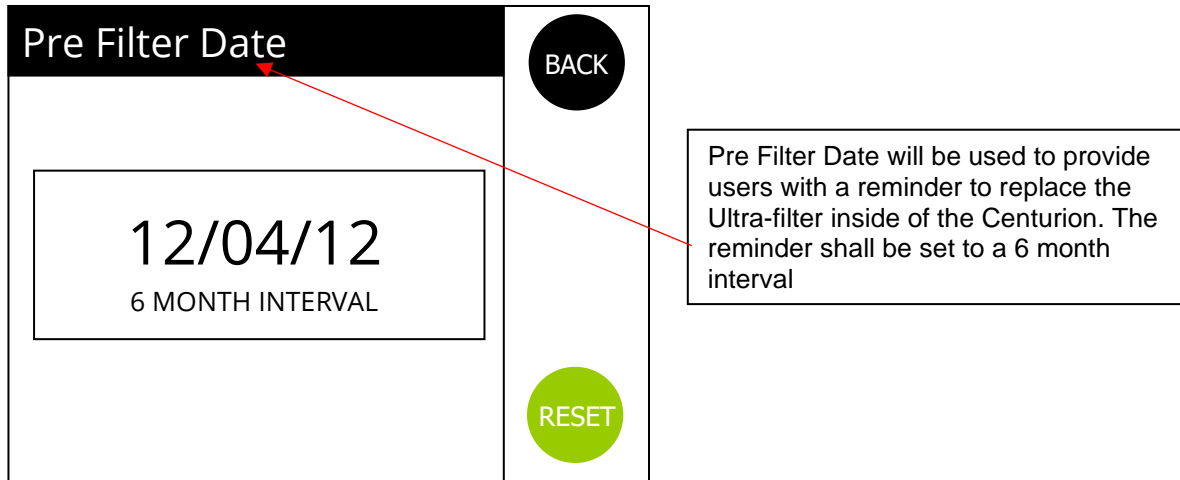

7.1.4 Product Information

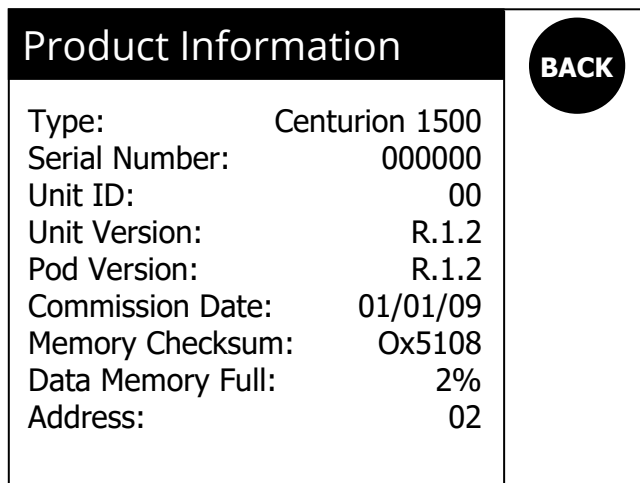

This screen shows the product details and software version numbers and is for information only.

7.2 Engineer Menu

**Warning:**

The 'Engineer Menu' is only accessible for use by trained and authorized personnel. If any data held within this menu is altered the performance/safety of the unit and/or water quality may be seriously affected. An access PIN number is required to enter this menu.

Refer to "Engineer menu" structure chart in **Section 7.4** which provides details of the sub-menus.

7.2.1 Language

There are 4 language options available, English UK, English US, French and Italian. To select the desired option simply press the corresponding box. A tick in the box will confirm selection.

7.2.2 Units

Select either "**Imperial units**" or "**Metric units**". To select the desired option simply press the corresponding box. A tick in the box will confirm selection.

If "**Imperial units**" selected;

- i) Temperature values in °F
- ii) Pressure values in (psi)
- iii) Flow rate in GPM (US gallons)

If "**Metric units**" selected;

- i) Temperature values in °C
- ii) Pressure values in (psi)
- iii) Flow rate in litres per min (L/m)

7.2.3 Alarms

"Audio Alarm enabled", select either "Disabled or Enabled". If enabled a buzzer will sound if an alarm condition should occur. The default setting will be "Enabled"

"Set Quality Alarm", the value for this will be factory pre-set. The value can be adjusted by using the ▲/▼ buttons. The value inputted relates to the permeate water quality and the level at which the unit will alarm should the water quality exceed this value.

The selectable range available will be between 5 and 100 µs/cm. The default setting will be set at 70 µs/cm. Entering a value of "0" will disable the alarm.

"Set Temp Alarm", the value for this will be factory pre-set. The value can be adjusted by using the ▲/▼ buttons. The value inputted relates to the temperature of the permeate water and the level at which the unit will alarm should the water temperature exceed this value.

The selectable range available will be between 68 to 95 °F. The default setting will be 95°C. Entering a value of “0” will disable the alarm.

If the measured water temperature should exceed 122°F the unit will shut down and return to “Power-on”.

7.2.4 Maintenance

(Refer to separate “Maintenance Menu structure in **Section 7.4 Table-1**)

“**Pump run hours**”, displays the number of hours the RO boost pump has been running. The option exists to reset this value to zero should a new pump be fitted by accepting the “Reset” command.

“**Pump On/Offs**”, displays the number of times the RO boost pump has cycled on/off. Can be used as a diagnostic tool when troubleshooting pump problems. The option exists to reset this value to zero.

“**Solenoids On/Off**”, records the number of times the “Inlet” solenoid has cycled on/off, or open/closed. The option exists to reset this value to zero should a new valve be fitted by accepting the “Reset” command.

“**Data transfer**”, there are three sub routines associated with this entry:-

“**Upload Files**”, this option allows for the downloading of stored processing data to be transferred to a USB memory device. On selecting this function and accepting the “Send” command stored logged data will be sent to the USB device. If no USB memory device is inserted the unit will display the following message “**Memory Device Not detected**”.

The USB memory device should be plugged into the USB port located at the rear of the unit, (see **Section 4.5**)

Only use USB memory devices specified in **Section 12.1.10**.

“**Clear Logger**”, if you wish to clear the stored logged data, press “**Clear**” then “**yes**” and the contents of the memory will be cleared. Clearing the log will reformat the memory on the Centurion. If an issue occurs where the logs cannot be retrieved, reformatting the memory will solve this.

“**Set Log Frequency**”, this function allows for the setting of the data logging interval. The selectable range is between 0 and 120 minutes, the default setting is set at 30 minutes. Entering a value of “0” will disable the function.

“**Software update**”, there are three sub routines associated with this entry:-

- “**Update Display**”
- “**Update Controller**”
- “**Update GUI**”

This function allows for the uploading of new software code. To upload new code insert a USB memory device, with the appropriate new code loaded, into the USB port at the rear of the unit.

Select the relevant item that requires new code and then select “**Yes**”. The new software file will then be uploaded, the progress being displayed on a percentage scale. Uploading of new code can take several minutes.

7.2.5 Data logging

All operating conditions and values are monitored and stored/recorded within the unit's internal memory. The data is saved as a CSV (comma separated variable) file which can be uploaded onto a USB data stick.

The logger will save all the relevant data to the unit's 1MB of internal logging memory. The data saved will include all status changes, alarms and process values.

The duration between when values get updated is adjustable. By default this Log Frequency time shall be 30 minutes, but can be adjusted within the Engineer Menu (see **Section 7.2.4**). With the default Log Frequency of 30 minutes set, the internal memory can easily store 6 months of data, potentially less if the Log Frequency is reduced.

The unit will continue to save data to the internal memory until the memory becomes full. When full any additional data will not be saved. The Product Information screen (see **Section 7.1.4**) will display the status of the internal memory as a 'data memory full percentage'.

The stored data files can be uploaded to a USB data stick whenever required. This can be carried out by selecting a “Data Transfer”. The Data Logger screen presented will enable you to either Upload Files to the external USB device, or Clear Logger of all saved data. Before the unit's logger memory is erased an “Are You Sure?” option shall be presented (see **Section 7.2.4**).

Note: Before erasing the unit's stored data with the Clear Logger option. It is advised to first check that the upload was successful by viewing the content of the USB device on a PC.

7.2.6 Setup

(Refer to SETUP Menu structure in **Section 7.4** Table-4 for details)

“**Calibration**”, there are four sub-menus within this function:-

- i) Permeate Line Cell Constant
- ii) Feed Line Cell Constant
- iii) Feed Line Cell Offset
- iv) Flow calibration

Permeate Line Cell Constant: The line cell constant displayed has an acceptable input range set between 0.05 and 1.00. If a value outside this range is entered it will be ignored.

The default value will be set at 0.65

Feed Line Cell Constant: The Feed line cell constant displayed has an acceptable input range set between 0.05 and 2.55. If a value outside this range is entered it will be ignored.

The default value will be set at 1.20

Feed Line Cell Offset: The Feed line cell offset displayed has an acceptable input range set between 0.01 and 1.00. If a value outside this range is entered it will be ignored.

The default value will be set at 0.10

The value changes the gain of the Feed quality circuit which is used to compensate for any component tolerance issues. A value of 0.10 represents unity (no gain adjustment)

Flow Calibration: This menu option displays a five-digit value; this value represents the number of pulses per litre provided from the flow sensor.

Any value between 0 and 60000 can be entered and saved.

If a value outside the allowable range is entered, the value will be ignored, and the previous value retained.

The pre-set default value is "22000".

If a value of "00000" is entered, the flow rate display will be disabled, i.e. the "Flow Rate" text and associated value will not be selectable or displayed on the STATUS BAR during *Processing*.

"Quality Options", there are four sub-menus within this function:

- i) Salt Display
- ii) Feed Quality Display
- iii) Leak shutdown
- iv) Leak Value Display

Salt Display: displays the % Salt rejection performance. The % Salt rejection is the ratio of the permeate quality to the inlet feed quality expressed as a %. It provides a method of determining the performance of the reverse osmosis membrane.

The default for this option is set at **"Enabled"**.

Feed quality Display: If **"Enabled"** the feed water quality displayed in $\mu\text{S}/\text{cm}$ will be displayed on the status bar during normal **"Processing"**.

The default option is set at **"Disabled"**.

Leak Shutdown: this option provides the option to stop the unit running should a leak be detected. If “Enabled” the unit will stop running. The volume of water required to trigger the leak detector is 300-400 mls.

The default setting for this option is “**Enabled**”.

Leak Value Display: If “**Enabled**”, the “Leak Quality” value will be displayed during “**Processing**”. During Heat disinfect, the pump pressure, flow rate, tank temperature, and ring temperature will be displayed on the screen. The default option is “**Disabled**”.

“**Boost Pump Speed**” the Boost Pump Speed is adjustable. There are three sub-menus within this function:

- i) Processing Speed %
- ii) Heat San Speed %
- iii) Chem Draw Speed %
- iv) Nocturnal Speed %

Processing Speed %: Refers to the speed at which the RO boost pump runs during all normal “**Processing**” states, including “**Standby Run**” mode.

The default setting for Processing speed is set at **80%**.

Heat San Speed %: Refers to the speed at which the RO boost pump runs during the Heat sanitisation process, including **Processing rinse**.

The default setting for Heat San speed is set at **50%**.

Chem Draw Speed %: Refers to the speed at which the RO boost pump runs during the **chemical draw** stage, including **rinse pipe** routine.

The default setting for Heat San speed is set at **80%**.

“**Clean Options**”, there are six sub-menu options within this function:

- i). Chemical Draw Time
- ii). Hold Period
- iii). Heat Draw Timer Enable
- iv). Heat Draw Timer Set
- v). Flow Cal Enable
- vi). Flow Cal Set
- vii). Heat Draw Enable/Disable

Chem Draw Time: refers to the time in seconds set for the drawing of chemical during a chemical clean routine. The time should be adjusted to draw the contents of the 250 ml chemical bottle.

The selectable range available is 0 to 99 seconds. The default settings being 45 seconds.

Hold Period: refers to the duration of the **Recirculation** (Temperature Hold) period within the **Heat sanitisation** routine.

Two options are available, 10 or 30 minutes. The default time is set at 30 minutes.

Heat Draw Timer Enable: If “**Enabled**” the heat draw timer set will need to be set by the user.

The default option is set at “**Enabled**”.

Heat Draw Timer Set: refers to the time in minutes set for the drawing of high temperature water during a heat draw. When this time expires the heat draw cycle will end and go into cool down.

The selectable range available is 0 to 999 minutes. The default setting is 60 minutes.

Flow Cal Set Enable: If “**Enabled**” the unit will enter calibration mode, which mimics heat draw. If “**Disabled**” the unit will exit calibration mode.

The default option is set at “**Disabled**”.

Flow Cal Set: refers to the value used for heat draw flow calibration.

The default setting is 300 mlm (this value will vary with each unit).

Heat Draw Enable/Disable: If “**Enabled**” then heat draw will appear on the “Clean” Screen. If “**Disabled**” heat draw will not appear on the “Clean” screen.

The default option is set at “**Enabled**”

“**Setup Options**”, there are seven sub-menu options available within this function:-

- i) Drain On Stop
- ii) Rear Fan Enabled
- iii) Switch Settings
- iv) Pump Retries
- v) Standby
- vi) Auto Restart
- vii) Reminders

Drain On Stop: This options provides the ability to enable or disable the “**Drain Down**” feature.

If “**Enabled**” on switching the unit off and returning to Power-on mode the unit will drain down to low level. The default setting is “**Enabled**”

Rear Fan Enabled: This option provides the ability to enable or disable the continuous running of the main rear fan. If “**Disabled**” the rear fan will only run during heat sanitisation routine, if “**Enabled**” the fan will run continuously whenever power is applied to the unit. The default setting is “**Disabled**”.

Switch Settings: This option is further categorized into setting up, *External Standby Switch Polarity* and *Tank High Level Switch Polarity*. In both cases the option exists to select the switch to be Normally Open (NO) or Normally Closed (NC).

The default settings for both options is set at (NO). Refer to AmeriWater for advice on selecting the correct option.

Pump Retries: Refers to the number of times the system will attempt to start the pump before a low-pressure alarm is activated. The default setting is 3.

“Standby”: *This feature provides two modes of standby:-*

- i) Power on Standby
- ii) Timed Standby

Power On Standby: This feature shall operate if the “Standby / Power On” menu option has been “Enabled”. Also the Standby: Timed menu option shall need to be “Enabled”. When both Standby options have been enabled, the unit shall run in a *Processing* state, after first performing a Start Up sequence, for 10 minutes every 2 hours. This periodic run sequence shall continue while the time is between the programmed “Standby / Time”, *On Time* and *Off Time*.

The POWER ON screen shall remain during both *Standby off periods* and *Standby run periods*.

Whenever both “Standby / Power On” and “Standby / Timed” are “Enabled”, a message “! Timed Standby Enabled” shall be displayed on the STATUS BAR.

Whenever the unit runs, during a *Standby run period*, a message “STANDBY RUN” shall be displayed on the STATUS BAR.

Timed Standby: Operates in the *External Standby* and *Power On Standby* states, if the “Timed Standby” menu option has been “Enabled”.

The Timed Standby option shall provide the ability to set an On/Start Time and an Off/End Time.

Outside of the entered time range, the unit shall not automatically start up and run in a *Power On* or *External Standby* state. Within the entered time range the unit shall automatically start up and run periodically whenever in an *External Standby* state, and in a *Power On* state if the “Standby / Power On” menu option is “Enabled”.

With the Timed Standby option “Enable” and the unit in an *External Standby* state, the unit shall periodically run between the programmed *On Time* and *Off Time*. After every 2 hour period the unit shall run for 10 minutes. During the 2 hour period all outputs shall be off, a message “Timed Standby Enabled” shall be displayed on the STATUS BAR.

After a 2 hour ‘off period’, the unit shall start up and run in a *Processing* state after first performing a Start Up sequence, this ‘run period’ shall continue for 10 minutes before

going back into a 2 hour 'off period'. During the 10 minute 'run periods' a message "STANDBY RUN PERIOD" shall be displayed on the STATUS BAR.

Auto restart: When the Auto Restart menu option has been "Enabled", the unit shall go back into the mode it was in prior to the power interruption (i.e. *Processing, Processing Standby* or *Power On*).

With Auto Restart – "Disabled" (default), the unit shall always go to POWER ON state after a power interruption (except when in a *Chemical Clean* routine,

Reminders: There are three sub menu options available in this feature:-

- i) Filter Replacement Interval
- ii) Heat San Interval
- iii) Chemical Clean Interval

Filter Replacement Interval: This menu option provides the ability to enable and select the interval for filter replacement. The options provided are given below:

- i) Disabled
- ii) 3 Month Interval
- iii) 6 Month Interval
- iv) 12 Month Interval

NOTE: The filter replacement interval will be used to set the Ultra-filter replacement interval. AmeriWater recommends this filter to be replaced every 6 months. See **Section 8.4** for more information

The default for this option is "6 Months". A replacement warning will display 6 months after the date set in the "Pre Filter Date" menu option.

The "Pre Filter Date" can be set under **MENU>Pre Filter Date**.

Heat Sanitisation Interval: This menu option provides the ability to enable and select the interval for heat sanitisation reminders. The options provided are given below:

- i) Disabled
- ii) 1 Week Interval
- iii) 2 Week Interval
- iv) 3 Week Interval

The default for this option shall be "Disabled".

Chemical Clean Interval: This menu option provides the ability to enable and select the interval for chemical clean reminders. The options to be provided are given below:

- i) Disabled
- ii) 1 Month Interval
- iii) 2 Month Interval
- iv) 3 Month Interval

“Commission Setup”: This function has four sub menu options available,

- i). Commission Date
- ii). Set Unit ID
- iii). Serial Number
- iv). Restore Defaults

Commission Date: This menu option displays the Commission Date of the unit, in the selected format.

The date should be set to the current date after the **Time and Date** has been set and the **Transit Mode** has been disabled. See below.

The date can be changed should the unit ever be decommissioned and then re-used at a later date.

The default Date for this option is 01/01/01.

Set Unit ID: This option offers a two digit ‘ID’ number to be entered.

The ID number may be used to uniquely identify a unit. This two digit ID number shall also form part of any Data Logged file name.

The default value for this option is ‘00’.

Serial Number: This option allows for a six digit “Serial Number” to be entered.

The number can be viewed and changed.

The default value for this option is “000000”.

Restore Defaults: When this option is selected, all the adjustable/selectable options will revert to the default options/values.

Refer to **Section 7.5 “Default Values”** for default options/values.

Transit Mode: The *Transit Mode* shall can be enabled and disabled

If the *Transit Mode* has been enabled, the “Set Time” and “Set Date” menu options will be displayed after *Initialization*.

While the setting Time and Date menus are being displayed, “Transit Mode” shall be displayed on the STATUS BAR.

Only after the Time, Date and the Filter Date options screens have been exited shall the POWER ON screen be presented.

The unit will be set in Transit mode on leaving the manufacturer.

7.3 Settings Menu

Warning:

The 'Settings Menu' is only accessible for use by trained and authorised personnel. If any data held within this menu is altered the performance/safety of the unit and/or water quality may be seriously affected. An access PIN number is required to enter this menu.

On selecting "Settings Menu", you will require a PIN number to gain access. (Refer to "Main menu" structure chart **Section 7.4 Table-2** for details)

Within "Settings menu there are two user standby functions:

- i) "Power On"*
- ii) "Timed"*

For both of the above standby options refer to **Section 7.2.6 Set Up**.

7.4 Menu Structure Diagrams

ENGINEERING MENU STRUCTURE

Table -1

Level 1	Level 2	Level 3	Level 4	Level 5	Level 6	Notes	Manual ref:
Power On	MENU*	Clean Time & Date Pre-Filter Date Product Info Engineer Menu	Enter PIN (9721)	Language	English UK English US French Italian	Select Option Select Option Select Option Select Option	8.0 7.1.2 7.1.3 7.1.4 7.2.1
				Units	Imperial Units Metric Units	Select Option Select Option	7.2.2
				Alarms	Audio Alarm Enabled Set Quality Alarm Set Temp Alarm		7.2.3
				Maintenance	Pump Run Hours Pump On/Offs Solenoid On/Offs Data Transfer Software Update	See Table 3 See Table 3 See Table 3 See Table 3 See Table 3	7.2.4
				Set Up	Calibration Quality Options Boost Pump Speed Clean Options Setup Options Commission Setup Transit Mode	See Table 4 See Table 4 See Table 4 See Table 4 See Table 4 See Table 4 See Table 4	7.2.5
				Settings Menu	Enter PIN	See Table 2	7.3

USER MENU STRUCTURE

Table -2

Level 1	Level 2	Level 3	Level 4	Level 5	Notes	Manual ref:
Power On	▲ MENU*	▲ Clean	▲ Chemical Clean ▲ Heat Disinfection ▲ Heat Dis Results ▲ Heat Draw ▲ Heat Draw Results			Section 8.2 Section 8.4 Section 8.4
		▲ Time & Date	▲ Set Time ▲ Set Date ▲ Set Format		Input correct time Input correct date select from 4 formats	Section 7.1.2 Section 7.1.2 Section 7.1.2
		▲ Pre-Filter Date ▲ Product Info ▲ Engineer Menu ▲ Settings Menu	▲ Power On ▲ Timed		auto set by unit Displays table of data See Table-1 Select Disabled/Enabled Select Disabled/Enabled Set HH:MM Set HH:MM	Section 7.1.3 Section 7.1.4 Section 7.3 Section 7.3 Section 7.3 Section 7.3
	▲ START			▲ Timed Standby Enabled ▲ Set on Time ▲ Set off Time		Section 7.3 Section 7.3 Section 7.3

MAINTENANCE MENU STRUCTURE

Table -3

Level 1	Level 2	Level 3	Notes	Manual ref:
Maintenance	<ul style="list-style-type: none"> ▲ Pump run hours ▲ Pump On/Offs ▲ Solenoid On/Offs ▲ Data Transfer 	<ul style="list-style-type: none"> ▲ Upload Files ▲ Clear Logger ▲ Set Log Frequency 	<ul style="list-style-type: none"> Displayed in " hours" Displayed as " cycles" Displayed as " cycles" 	<ul style="list-style-type: none"> Section 7.2.4 Section 7.2.4 Section 7.2.4 Section 7.2.4 Section 7.2.4 Section 7.2.4
	<ul style="list-style-type: none"> ▲ Software Update 	<ul style="list-style-type: none"> ▲ Update Display ▲ Update Controller ▲ Update GUI 		<ul style="list-style-type: none"> Section 7.2.4 Section 7.2.4 Section 7.2.4

SET UP MENU STRUCTURE

Table -4

Level 1	Level 2	Level 3	Level 4	Notes	Manual ref:
Set Up	Calibration	Line Cell Constants	Permeate Line Cell	Factory Set Value	7.2.6
			Feed Line Cell	Factory Set Value	"
			Feed Line Cell Offset	Factory Set Value	"
		Flow Calibration		Factory Set Value	"
		Touch Screen Calibrate		Do Not Adjust	"
	Quality Options	Salt Display		Select Disabled/Enabled	"
		Feed Quality Display		Select Disabled/Enabled	"
		Feed Error Shutdown		Select Disabled/Enabled	"
		Leak Shutdown		Select Disabled/Enabled	"
		Leak Value Display		Select Disabled/Enabled	"
	Boost Pump Speed	Processing Speed %		Set From 10-100%; 0 to 100 Disables	"
		Heatsan Speed %		Set From 10-100%; 0 to 100 Disables	"
		Chem Draw Speed %		Set From 10-100%; 0 to 100 Disables	"
		Nocturnal Speed %		Set From 10-100%; 0 to 100 Disables	"
	Clean Options	Chemical Draw Time		Factory Set time in Seconds	"
		Hold Period		Select 10 or 30 mins	"
		Heat Draw Timer Enable		Select Disabled/Enabled	"
		Heat Draw Timer Set		Set from 0 – 999 minutes	"
		Flow Cal Enable		Disabled / Enabled	"
		Flow Cal Set		355	"
		Heat Draw Enable/Disable		Disabled / Enabled	"
	Setup Options	Drain On Stop		Select Disabled/Enabled	"
		Rear Fan Enable		Select Disabled/Enabled	"
		Switch Settings	Ext Stby Switch Pol	Select NO/NC	"
			Tank High Switch Pol	Select NO/NC	"
		Pump Retries		Set 1 – 7, default setting is 3	"
		Standby	Power On		"
			Timed		"
		Auto restart		Select Disabled/Enabled	"
		Reminders	Filter Replacement Int	Select 3, 6 or 12 months	"
			Heat San Interval	Select 1, 2 or 3 weeks	"
			Chem Clean Interval	Select 1, 2 or 3 months	"
	Commission Setup	Commission Date		Set date of commissioning	"
		Set Unit ID		Set on commissioning	"
		Serial Number		Input Serial Number	"
		Restore Defaults		Confirm Yes/No	"
	Transit Mode			Select Disabled/Enabled	"

7.5 Factory default settings

Engineer menu	Default Values	User Values
Language		
English UK	✓	
English US	-	
French	-	
German	-	
Units		
Imperial	-	
Metric	✓	
Alarms		
Audible Alarm Enable	Enabled	
Set Quality Alarm	70uS	
Set Temp Alarm	95.0°F	
Maintenance		
Pump Run Hours	0 Hours	
Pump On/Offs	0 Cycles	
Inlet Solenoid On/Offs	0 Cycles	
Data Transfer	-	
Upload Files	-	
Clear Logger	-	
Set Log Frequency	30 minutes	
Software Update	-	
Update Display	-	
Update Controller	-	
Update GUI	-	
Setup		
Calibration		
Line Cell Constants	-	
Permeate Line Cell	0.65	
Feed Line Cell	1.20	
Feed Line Cell Offset	0.10	
Flow Calibration	22000	
Touchscreen Calibration	-	
Quality Options		
Salt Display	Enabled	
Feed Quality Display	Enabled	
Feed Error Shutdown	Disabled	
Leak Shutdown	Enabled	
Leak Value Display	Disabled	
Boost Pump Speed		
Processing Speed %	80%	
Heat San. Speed %	50%	
Chem Draw Speed %	80%	
Clean Options		
Chemical Draw Time	50 Seconds	
Hold Period		
10 Minutes	✓	
30 Minutes	-	

Heat Draw Timer Enable	Enabled	
Heat Draw Timer Set	60 minutes	
Flow Cal Enable	Disabled	
Flow Cal Set	300 (may vary)	
Heat Draw Enable/Disable	Enabled	
Set Up Options		
Drain On Stop	Enabled	
Rear Fan Enable	Disabled	
Switch Settings		
Ext Stby Switch Pol.	Normally Open	
Tank High Switch Pol.	Normally Open	
Pump Retries	3	
Standby	-	
Power On	Disabled	
Timed	Disabled	
Set On Time	06:00	
Set Off Time	20:00	
Auto restart	Disabled	
Reminders	-	
Filter Replacement Interval		
Disabled	-	
3 Month Interval	-	
6 Month Interval	✓	
12 Month Interval	-	
Heat San. Interval		
Disabled	✓	
1 Week Interval	-	
2 Week Interval	-	
3 Week Interval	-	
Chem Clean Interval		
Disabled	✓	
1 Month Interval	-	
2 Month Interval	-	
3 Month Interval	-	
Commission Setup		
Commission Date	-	
Set Unit ID	01	
Serial Number	-	
Restore Defaults	-	
Transit Mode	Disabled	

8 CHEMICAL CLEANING, HEAT DISINFECTION, AND HEAT DRAW

8.1 Explanation – why does the unit require regular cleaning/heat disinfection.

The process by which the unit purifies water is reverse osmosis (RO). This process uses a very fine filter, generally referred to as a membrane which removes dissolved minerals and bacteria from the water supply. Over time these impurities can build up on the surfaces of the membrane. To maximize the life of the RO membrane and to ensure the permeate quality meets the requirements for hemodialysis, regular chemical cleaning and heat disinfection of the unit is recommended to remove minerals and bacteria that may have built up on the membrane.

All processes have been designed to be as simple and automatic as possible.

The display screen will guide you through the process with a series of instructions at every stage.

To avoid handling the chemicals and the risk of spillages the unit incorporates a system which automatically draws the chemical cleaning agent directly from the chemical cleaner bottle into the unit.

8.1.1 Frequency

The need for cleaning and disinfection will vary from patient to patient, location, and will depend on the quality of the incoming water supply. For example, where a high degree of bacterial control is required regular heat disinfection is recommended. In areas where an un-softened water supply is used (i.e. has high levels of dissolved calcium and magnesium salts) it is recommended that a high and low pH chemical cleaning is carried out quarterly. A cleaning schedule when using a softened water supply may be based on a loss of flow and/or water quality. Environmental conditions may warrant more frequent cleanings of the membrane.

<p>Note: Your Healthcare Provider will carry out an assessment of your water supply and provide you with a schedule for cleaning and heat disinfection. DO NOT carry out any additional cycles, unless you have approval by your healthcare provider that it is acceptable to do so.</p>
--

8.1.2 Cleaning/disinfection chemicals

Your Healthcare provider will supply you with the necessary chemical cleaning agents suitable for your unit.



Warning:

DO NOT use any other household cleaner to clean the unit, only use those cleaners supplied by AmeriWater, or your Healthcare provider or you may risk causing severe damage to the unit and its components and pose a serious risk to yourself or the person on dialysis.

8.1.3 Chemical selection guideline

AmeriClean A is a powder based acid cleaner for descaling and iron removal.

AmeriClean B is a multi-purpose alkaline cleaner, containing sequestrants, detergents and emulsifiers for the removal of dissolved/colloidal organic compounds.



Warning:

Do not use AmeriClean A/B while the ultra-filter is installed.

Note: Your Healthcare provider will provide a cleaning program based on your specific requirements and frequency of dialysis.

AmeriClean A/B MUST NOT be used with the ultra-filter installed.

8.1.4 Mixing Instructions for Americlean A and Americlean B

The **Americlean A** and **B** chemical cleaners are supplied in a kit (P/N 37-0006 AmeriClean A or 37-0007 AmeriClean B) containing enough cleaner for 12 cleanings and 2 bottles. The following instructions detail the method required for mixing the chemical solution for use in the cleaning. The cleaning solution will be mixed each time a cleaning of the RO membrane is required.

1. Locate a bottle of the desired cleaner containing the cleaning powder out of the kit. The bottle will be marked Americlean B for the high pH cleaner or Americlean A for the low pH cleaner.
2. Add **1.5 tablespoons** of **AmeriClean A** powder or **2 tablespoons** of **AmeriClean B**. The label on the bottle provides information for mix volumes.



Note: Never Mix AmeriClean A and B. Always use different measuring devices and bottles for each cleaner solution if both a high and low pH cleaning are being conducted.

3. Fill the 237 ml bottle using clean water (RO or DI water is preferred when possible). Use water at 86 °F for best results. Water should not exceed 110 °F. Reinstall the lid on the bottle.
4. Shake the solution very well until the powder is completely dissolved.
5. Once the powder is dissolved in the solution completely, verify the pH of the solution. Americlean A should have a pH of 2-3 and Americlean B should have a pH of 10-11. When the pH is verified, the cleaner is ready for use.
6. Cleaning should be performed using the **High pH cleaner first** to remove inorganic scale and metals followed by the **Low pH cleaner second** to remove insoluble foulants following the steps described in **Section 8.2**.
7. Once the cleaning is completed following the steps described in **Section 8.2**, rinse out the bottle provided in the kit and store until next use.

8.2 Chemical cleaning

To maximize the life and maintain the performance of the unit's reverse osmosis membrane and to ensure the permeate quality meets the requirements for hemodialysis, chemical cleaning of the unit is recommended. Refer to **Section 8.1** for information on recommended frequency of chemical cleaning.

**Warning:**

DO NOT use any other household cleaner unapproved chemical not authorized by **AmeriWater** or referenced in the **Chemical Cleaning and Heat Disinfection Instructions** to clean the unit, only use those cleaners supplied by **AmeriWater**, or you may risk causing severe damage to the unit and its components and pose a serious risk to yourself or the person on dialysis.

To start the chemical cleaning routine just follow the simple on screen prompts which will guide you through every step of the sequence.

NB: The approximate duration of the cleaning cycle is 90 minutes.

8.2.1 Chemical clean sequence

Displayed Screen

Operator Action/s

Step-1

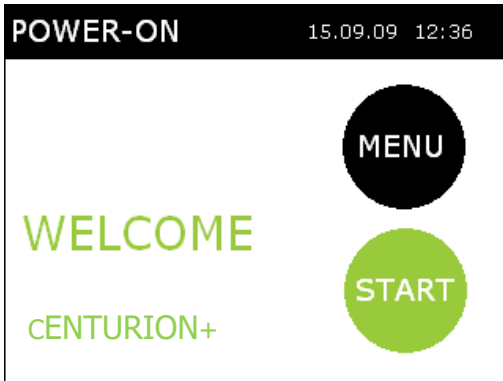

From the “POWER-ON” screen select “MENU”. The “USER MENU” will be then displayed.

Step-2

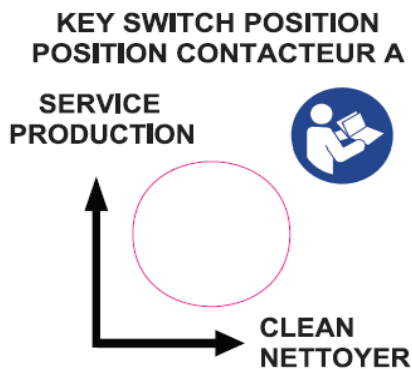

Turn the key switch on the rear of the unit to the “CLEAN” position. If this is not selected the unit will revert back to the “POWER-ON” screen if a chemical clean is attempted.

Step-3

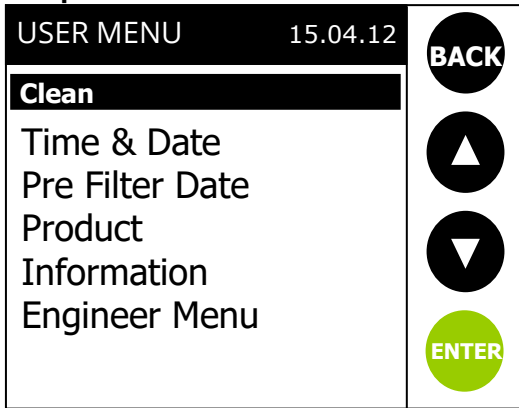

From the drop down USER MENU list select **“CLEAN”**, press **“ENTER”** to proceed to the next step.

Step-4

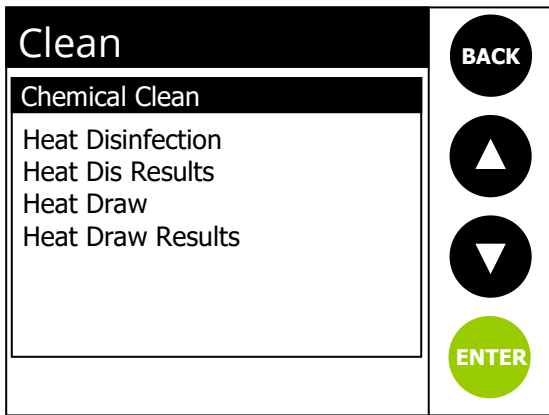

Select **“Chemical Clean”** from the menu listing then press the **“ENTER”** button.

Step-5

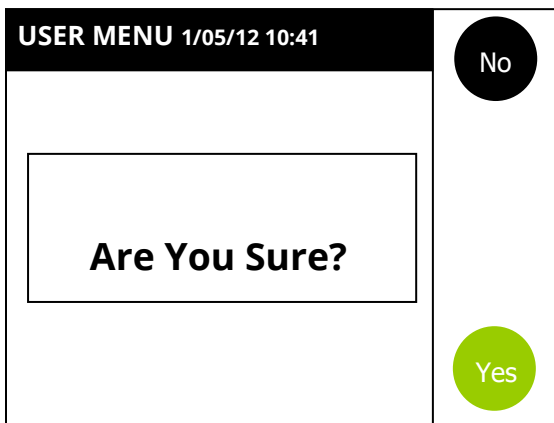

When the message **“Are You Sure?”** is displayed; press **“YES”**. **You will then be prompted to turn the key at the rear of the unit to the “CLEAN” position.** The chemical clean routine will then start. If you select **“NO”** you will return to the **“POWER-ON”** screen.

Step-6

Cleaning

Cleaning
Tank Filling



2%

 **CHEMICALS RECIRCULATING**

The unit will automatically adjust the level of water in its internal tank before the chemical cleaning agent is added. This will only take a few seconds and automatically proceed to the next stage.

Step-7

Cleaning

Cleaning

Disconnect From Dialysis Machine

Press CLEAN to continue



Now disconnect the external water loop from the inlet of the dialysis machine to ensure that no chemicals can be fed into the dialysis machine, Press, **“CLEAN”** to continue to the next step.

Step-8

Cleaning

Cleaning

Insert Draw Tube Into Bottle

Press CLEAN to continue



Unscrew the lid on the top of the chemical. The cleaning solution mix instructions can be found in section 8.1.4. Once the solution is made, place the 4 mm tubing connected to the **“ACID”** port at the rear of the unit into the bottle. Make sure the tube goes all the way down to the bottom. Press **“CLEAN”** to continue to the next step.

Step-9

Cleaning

Cleaning chemical draw

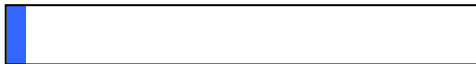

2%

 **CHEMICALS RECIRCULATING**

The chemical in the bottle will now be sucked into the unit. This should only take about 30-60 seconds. At the end check to make sure the bottle is empty. (It is normal for a very small amount to remain in the bottle). The unit will automatically continue to the next step.

Step-10

Cleaning

Cleaning

Fill Bottle with Water To Rinse Pipe

Press CLEAN to continue



To rinse the clear tubing fill the bottle with tap water and replace the tubing back into the bottle, then press **"CLEAN"**.

Step-11

Cleaning

Cleaning Draw Pipe Rinse



10%

 **CHEMICALS RECIRCULATING**

The water in the bottle will then be drawn up through the tubing to rinse it free of chemical

Step-12

Cleaning

Cleaning
Recirculation



15%

CHEMICALS RECIRCULATING

The unit will automatically recirculate the cleaning chemical for approximately 30 minutes and then carry out both high pressure and low pressure flushing cycles so don't be alarmed if the unit sounds different to normal operation.

Step-13

Cleaning

Cleaning
Rinse Cycle



40%

CHEMICALS RECIRCULATING

At the end of the recirculation cycle the unit will go immediately into a rinse cycle flushing the cleaning chemicals out of the unit for approximately 45 minutes

Step-14

Cleaning

Service Flush

Test For Residue Of
Cleaning Chemicals

When Water Is Acceptable
Press CLEAN to continue



Once the unit has finished its first rinse it will then enter into the final Flush routine. During this part of the cycle the purified water should be tested using the chemical test strips supplied by your Healthcare provider. The "**Service Flush**" cycle lasts for 10 minutes. If the Clean button is not pressed within 10 minutes it will repeat the "Service Flush" again until the water is acceptable. If the water shows clear of chemical press the "**CLEAN**" button to enter the final stage of the process. If the tests still show positive leave in Flush mode until acceptable.



Warning:

It is essential that the water quality is checked and free from chemicals before use and that you are satisfied it is safe to dialyse. If you are unsure about the quality of the water always seek advice from your Healthcare Provider.

If after two 10 minute flush cycles have taken place and the test for residual cleaning chemical is still unacceptable, contact your Healthcare provider or **AmeriWater** for advice. DO NOT use the unit until it is safe to do so and instructed by your Healthcare provider.

Step-15

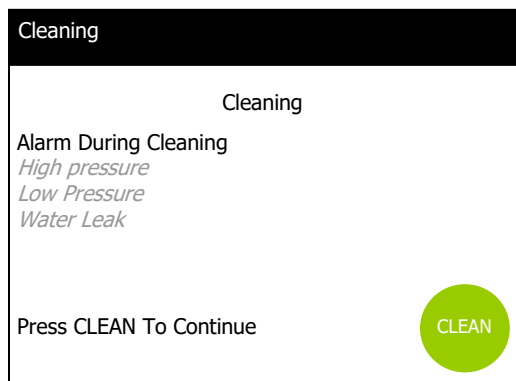

If the unit detects a fault during the chemical clean process, this alarm screen will be displayed along with a message relating to the possible fault. Pressing '**CLEAN**' will resume the process if safe to do so. If pressing "**CLEAN**" does not resume the disinfection sequence, or the alarm screen keeps appearing, refer to Section 10.0

Step-16

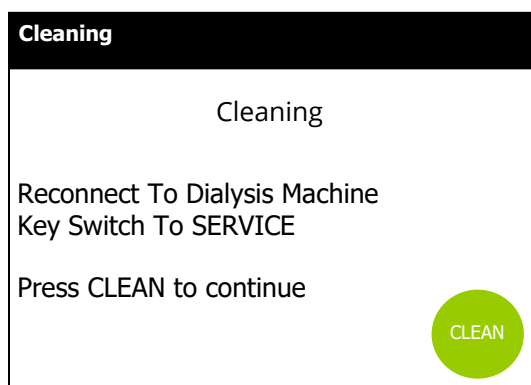

Once the water has tested clear of chemical the next step will be to reconnect the external water loop back up to the dialysis machine. Turn the key located at the rear of the unit to the "**SERVICE**" position. Press "**CLEAN**" and this should take you back to the "**POWER-ON**" screen ready for your next dialysis session.

8.3 Interruption to electrical supply during the chemical clean cycle

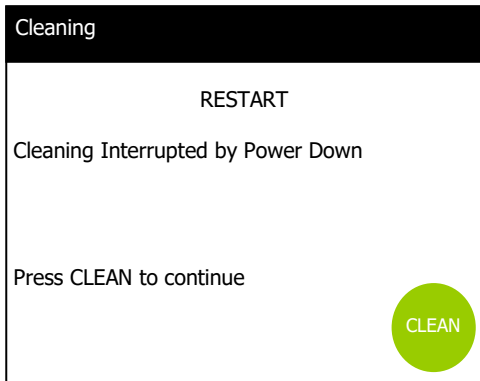

If there is an interruption in the electrical supply the chemical cleaning process will stop. Once the electrical supply is restored a text screen message “**Cleaning Interrupted by Power Down**” will be displayed. Press “CLEAN” to continue. This is to ensure that the unit is fully rinsed free of chemical before further dialysis can take place.



Warning:

Once started the chemical cleaning process has to be completed. If there is an interruption the program resumes from the point where the interruption took place. This is to ensure the unit is rinsed free of any chemical residues.

8.4 Heat disinfection

It is recommended to carry out a Heat Disinfection once **weekly** with regular use of the RO. If the RO sits for 72 hours without use, a disinfection is recommended before use.

**Warning:**

Failure to heat disinfect the unit or carry out recommended chemical cleans could result in a deterioration of the water quality provided by the unit making it unsuitable for hemodialysis.

To start a heat disinfection routine just follow the simple on screen prompts which will guide you through every step of the sequence.

AmeriWater recommends that the ultra-filter be replaced after **26** total heat disinfection / draw cycles, when reduced flow is observed, or when breakthrough occurs. Swelling of the filter body is expected after heat disinfection. The swelling has no direct effect on the performance of the filter. When disinfection is completed more frequently than once per week and or heat draw more than once a month, more frequent replacement may be necessary. 6-month recommendation replacement cycle if only performing heat disinfection. Under no circumstances should the ultra-filter be left in service for longer than six months.

Warning:

Exceeding 26 total heat disinfection/draw cycles with the ultra-filter greatly increases the risk of breaking the internal fibers in the filter, compromising the integrity of the filter and causing it to lose effectiveness.

Note: For Centurions that have a serial number starting with “40xxxx”, adjust the pump speed to 40% for heat disinfection to ensure that 26 total heat disinfection/draw cycles can be achieved with no degradation of the ultra-filter.

8.4.1 Heat disinfection sequence

Step-1

Displayed screen

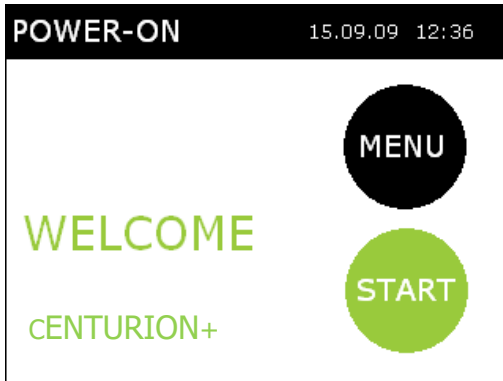

Operators actions/notes

From the **"POWER-ON"** screen select **"MENU"**

Step-2

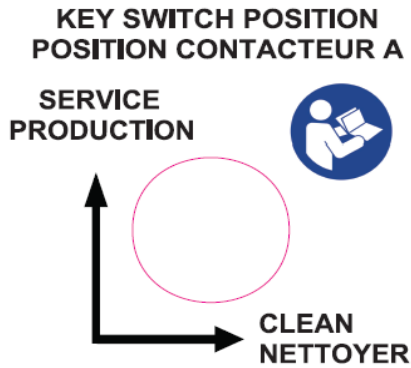

Turn the key switch on the rear of the unit to the **"CLEAN"** position.

If this is not selected the unit will revert to the **"POWER-ON"** screen if a heat disinfection is attempted.

Step-3

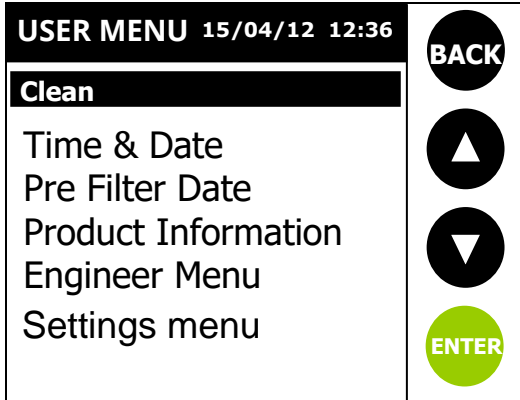

Select "**CLEAN**" from the USER MENU list.

Step-4

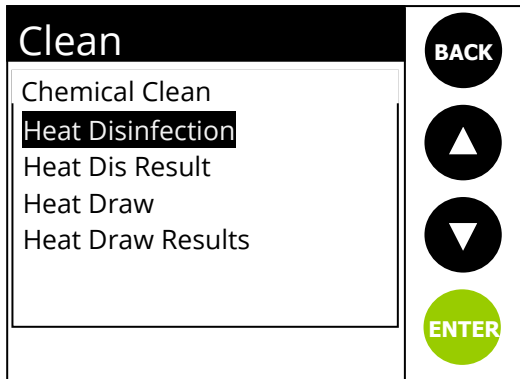

Select "**Heat Disinfection**" from the menu listing then press the "**ENTER**" button.

Step-5

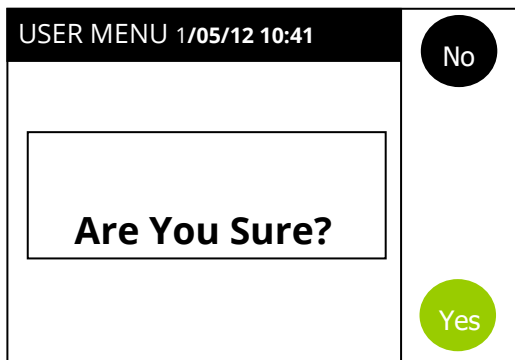

When the "**Are You Sure?**" message is displayed; press "**YES**" and the heat disinfection routine will start. If you select "**NO**" you will return to the "**POWER-ON**" screen

Step-6

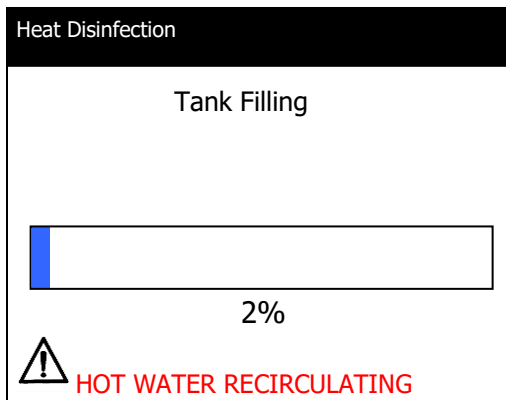

At the start of the cycle the unit’s internal tank will fill with water.

The progress bar at the bottom of each screen tells you how much of the disinfection cycle has completed.

Alarm/warning messages will also be displayed.

Step-7

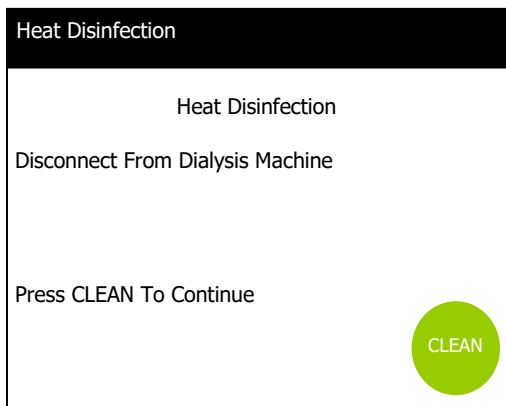

Once the unit’s internal tank has filled with the correct amount of water the following message will ask you to disconnect the distribution manifold connection from the Dialysis machine. This will stop any chance of hot water from entering the dialysis machine and possibly causing any damage.

Select “**CLEAN**” to continue to the next step.

Step-8

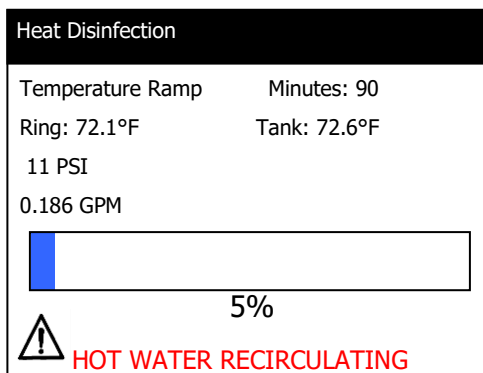

The unit now carries out some internal safety checks. If all checks are complete, the unit will then start to heat the water up. If the unit does not reach temperature within 90 minutes the unit will revert to a rinse cycle and the alarm message “**Heatsan failure**” will be displayed.

If this should happen refer to **Troubleshooting** Section 10.0

Step-9

Heat Disinfection

Recirculation	Minutes: 30
Ring: 189.3°F	Tank: 176.9°F
49 PSI	
0.346 GPM	

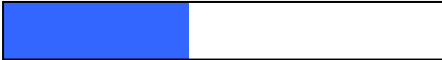

48%

 **HOT WATER RECIRCULATING**

When the unit reaches disinfection temperature it will then continue to recirculate (the standard period is 30 minutes).

The temperature of the water in the unit's tank and the temperature of the water recirculating around the distribution loop is also displayed.

Step-10

Heat Disinfection

Rinse Cycle

Ring: 157°F	Tank: 161°F
50 PSI	
0.346 GPM	



92%

 **HOT WATER RECIRCULATING**

After the unit has performed its disinfection recirculation period it carries out a rinse cycle until the water temperature reaches 95°F. The unit must be 95°F or below for 10 minutes. If the temperature increases above 95°F during the rinse, the 10 minute counter will restart.

Step-11

Heat Disinfection

Heat Disinfection

Reconnect to Dialysis machine

Key Switch to SERVICE

Press CLEAN to continue



Next reconnect the distribution manifold to the inlet of the dialysis machine.

Turn the key switch at the rear of the unit to the "SERVICE" position.

Select **CLEAN** to continue to the next step. After this the "**POWER-ON**" state will be displayed and the message "**Heat Dis Completed**" displayed.

Step-12

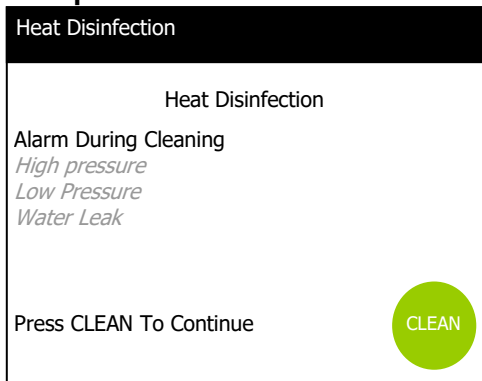

If the unit detects a fault during the heat disinfection process, this alarm screen will be displayed along with a message relating to the possible fault. Pressing **'CLEAN'** will resume the process if safe to do so. If pressing **"CLEAN"** does not resume the disinfection sequence, or the alarm screen keeps appearing, refer to Section 10.0

Step-13

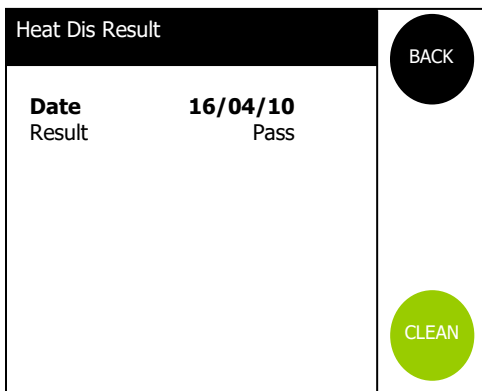

The **Heat Dis Result** screen (from the **Clean** menu) will show the result of the last heat disinfection together with any failure message if relevant. Refer to Section 10.0 **"Troubleshooting"** and contact your Healthcare provider if necessary

8.5 Heat Draw

Disinfection of the feed water hose to the Hemodialysis machine is recommended a minimum once a month. Environmental conditions may warrant more frequent disinfections.

To start a heat draw routine just follow the simple on screen prompts which will guide you through every step of the sequence.

AmeriWater recommends that the ultra-filter be replaced after **26** total heat disinfection / draw cycles, when reduced flow is observed, or when breakthrough occurs. Swelling of the filter body is expected after heat disinfection. The swelling has no direct effect on the performance of the filter. When disinfection is completed more frequently than once per week and or heat draw more than once a month, more frequent replacement may be necessary. 5-month replacement cycle is the recommendation based on 26 total heat disinfection / draw cycles. Under no circumstances should the ultra-filter be left in service for longer than six months.

Warning:

Exceeding 26 total heat disinfection/draw cycles with the ultra-filter greatly increases the risk of breaking the internal fibers in the filter, compromising the integrity of the filter and causing it to lose effectiveness.

Note: For Centurions that have a serial number starting with “40xxxx”, adjust the pump speed to 40% for heat disinfection to ensure that 26 total heat disinfection/draw cycles can be achieved with no degradation of the ultra-filter.

Note: Heat Draw process does not disinfect the Centurion Unit. The intended use is to disinfect the hosing connected to the hemodialysis machine from the Centurion Unit. To perform a complete disinfection of the Centurion Unit and the inlet tubing, execute a Heat Draw then follow up with a Heat Disinfect.

Note: Ensure all components of the hemodialysis machine are heat rated to the temperature of 200°F. Failure to do so could result in damages to the hemodialysis machine.

Note: AmeriWater recommends for the Heat Draw process to have incoming water to the Centurion at a temperature range of 60°F to 85°F, as well as using an insulated hose with a total length of 11ft to the hemodialysis machine. The Centurion product hose is 7ft insulated tubing, the remaining insulated inlet tubing to hemodialysis machine is 4ft. Inlet tubing length should be reduced to the shortest length allowable to the hemodialysis machine to maximize performance.

8.5.1 Heat Draw sequence

Step-1

Displayed screen

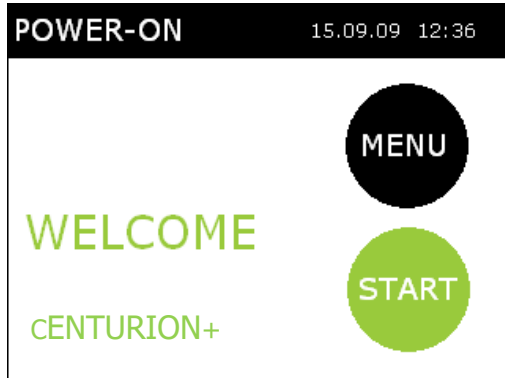

Operators actions/notes

From the “POWER-ON” screen select “MENU”

Step-2

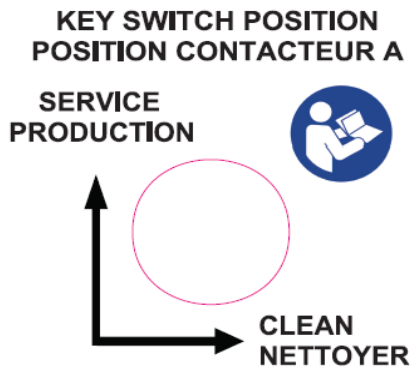

Turn the key switch on the rear of the unit to the “CLEAN” position. If this is not selected the unit will revert to the “POWER-ON” screen if a heat disinfection is attempted.

Step-3

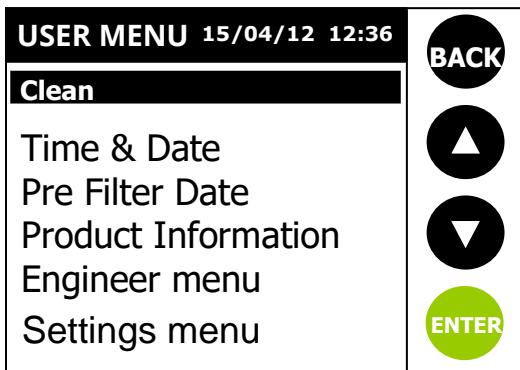

Select “CLEAN” from the USER MENU list.

Step-4

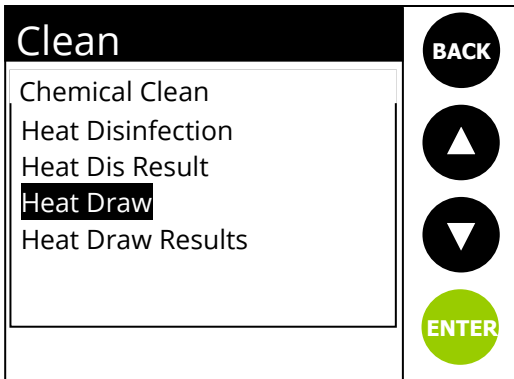

Select “**Heat Draw**” from the menu listing then press the “**ENTER**” button.

Step-5

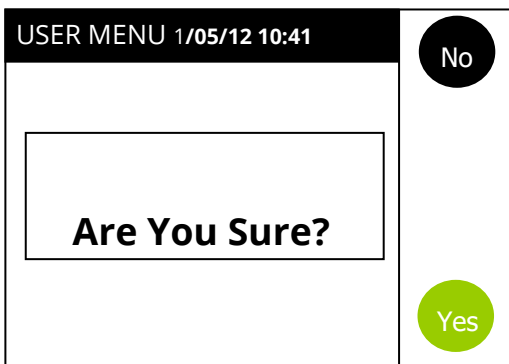

When the “**Are You Sure?**” message is displayed; press “**YES**” and the heat draw routine will start. If you select “**NO**” you will return to the “**POWER-ON**” screen

Step-6

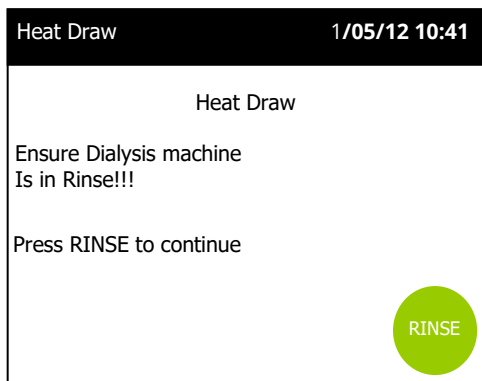

Ensure that the connected Dialysis machine is in Rinse prior to starting Heat Draw. Once confirmed that the Dialysis machine is in Rinse press “**RINSE**”.

Step-7

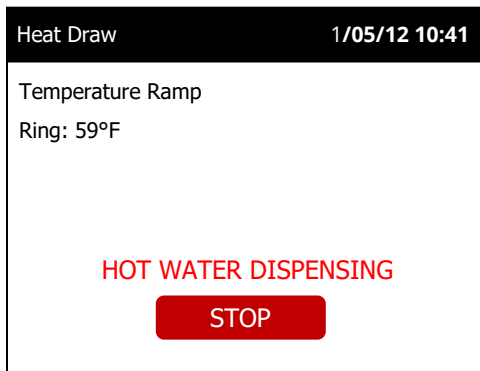

The unit now carries out a flush and then it will begin to heat the water to a disinfect temperature. The mode of operation will dispense hot water out of the product hose like supply mode.
Heat Draw requires a temperature ramp of 15 minutes and cool down of 5 minutes. (i.e. To ensure the dialysis machine achieves 30 minutes of contact time set the Dialysis rinse cycle to 50 minutes).

Step-8

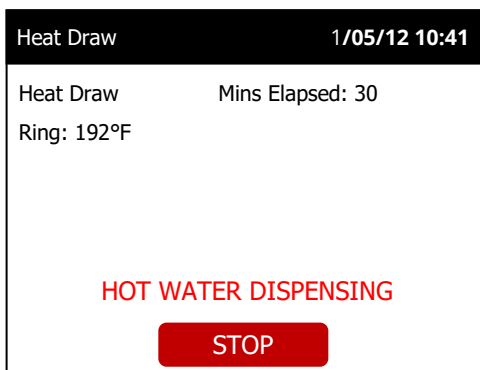

Temp hold will keep the water between 192°F ±5°F. Temp Hold will continue working until one or more of the *stopping conditions* are met: Manual Stop, Duration Exceeded, Temperature Exceeded, Power Interruption, or Water Loss.

Step-9



Once one or more of the stopping conditions have been met a Cool Down will begin until the water temperature reaches 95°F. The unit must be at 95°F or below for 180 seconds. The cool down will end and the system will go to the main screen.

Step-10

Heat Draw Result	
Date:	16/04/10
Duration:	3 Minutes

BACK

The **Heat Draw Result** screen (from the **Clean** menu) will show the result of the last heat draw with the date, time and stopping condition, if relevant. Refer to Section 10.0 “**Troubleshooting**” and contact your Healthcare provider if necessary.

8.6 Sample Port / Quick Disconnection Disinfection Procedure

Environmental conditions may warrant a monthly spot disinfection of the stainless steel sampling port and quick disconnect fitting on the product discharge manifold for the Centurion by AmeriWater. The following steps may be followed if a disinfection is needed.

STEP 1. Disconnect the Centurion from any dialysis machines.

STEP 2. Wipe down the outside of the sample port and quick disconnect fitting with an alcohol swap.

STEP 3. Using a syringe, fill the inside of the sample port with a small amount of isopropyl alcohol. Allow the solution to dwell for about 1 minute. Residual heat in the sample port during the heat disinfection cycle helps kill bacteria that may form inside the sample port

STEP 4. While the Centurion is running, let water run out of the port for a short period of time before taking samples to ensure there is no alcohol contamination in the sample taken.

STEP 5. Attach the system back to the dialysis machine and return to operation.

9 MAINTENANCE AND CHECKS

9.1 Planned routine checks

It is recommended that regular checks are carried out on the unit and its performance to ensure safe and uninterrupted operation. Refer to table below for details.

The frequency of performing the checks indicated should be considered as a guide only and will depend on how often the unit is operated over a period of time.

Task detail	Typical range of values	Typical frequency	Comments
Pre-Dialysis checks		Before each dialysis session	Refer to Section 9.6 for details.
Dialysis water quality: Chemical contaminants	Maximums as listed in Tables 1 & 2 of ANSI/AAMI/ISO 13959:2009	Yearly	Refer to Section 10.1.3 if limits unacceptable
Bacterial growth and Endotoxin concentration in dialysis water	<100 cfu/ml Bacteria <0.25 EU/ml Endotoxin (as per ANSI/AAMI/ISO 13959:2009)	Monthly	Refer to Section 10.1.3 if levels are unacceptable.
Purified water output	Min 0.40 USgals/min @ 50°F	Monthly	Refer to Section 10.1.3 if output is unacceptable..
Hot water disinfection	Min temp 176°F Min hold time 10 mins	Once per week (min)*	Record of last heat disinfection cycle can be viewed. Ref to Section 8.4.1, step 13
Heat Draw	Min temp 176F at hemodialysis See hemodialysis manual for hold time	Monthly	Record of last heat draw cycle can be viewed. Ref to Section 8.5.1, step 10
Chemical clean	N/A	Quarterly**	Refer to Section 8.1
Electrical safety inspection		Yearly or following a leak or electrical repair	Refer to Section 9.1.1
Labels	Refer to Section 3.1.1	yearly	Ensure all labels are present and legible.

9.1.1 Electrical safety inspection and test protocol

It is recommended that an electrical safety inspection is carried out:

- (i) On newly acquired equipment prior to being accepted for use.
- (ii) During routine planned preventative maintenance.
- (iii) After any repairs have been carried out on equipment.
- (iv) Following repair of a leak.



Warning:

1. A patient should never be connected to a piece of equipment that has not been checked.
2. An approved/trained medical equipment safety tester must be used, and capable of performing tests in accordance with the measuring circuits defined in the Medical Electrical Equipment standard 60601-1 (3rd edition)

Test	Notes	Limit
Earth continuity NC	Use test current of 1A or less. With the testers probe connected to the unit's internal stud located on the rear metal cover, refer to stud location diagram.	<0.2Ω
Insulation	Measure between L and N connected together and E, with 500V DC applied.	>20MΩ
Earth leakage current NC	L1 and L2 right way round	<0.5mA
Earth leakage current NC	L1 and L2 wrong way round	<0.5mA
Earth leakage current SFC	Protective earth open circuit	<10mA
Touch leakage NC		<0.1mA
Touch leakage SFC	Protective earth open circuit.	<0.5mA

Earth Continuity Test - location diagram of test stud

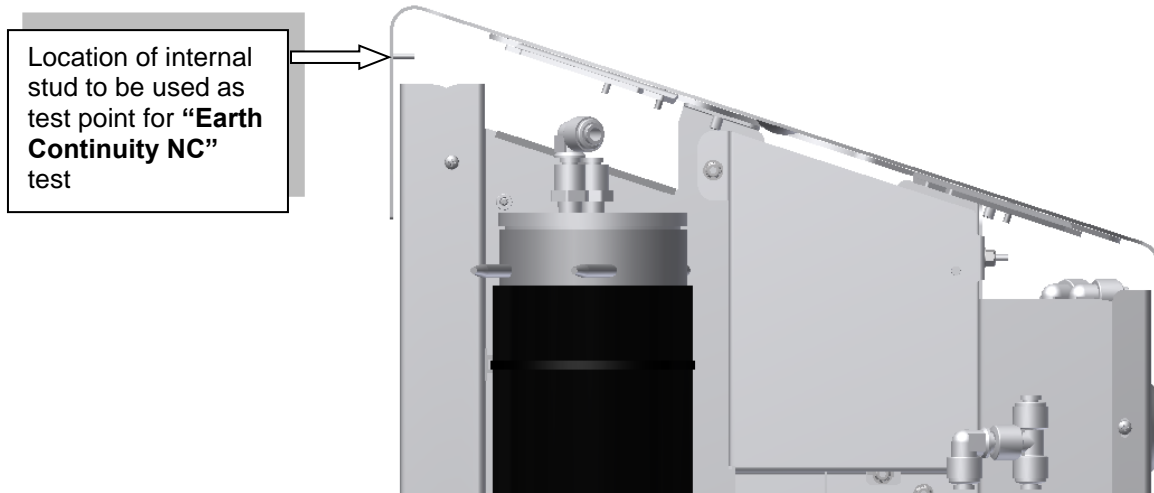

9.2 Planned preventative maintenance schedule

The unit has a designed operational life of a minimum of 5 years. The components listed in the preventative maintenance schedule have the potential for failure during that 5 year lifespan, depending on feed water conditions, environmental conditions, and routine maintenance of the device. Therefore, replacement is suggested as a preventative measure only. Replacement of these components at the interval recommended in the preventative maintenance schedule is **NOT** mandatory for the safe and effective operation of the device. Alternatively, the components may be replaced as needed due to component failure. The planned preventative maintenance schedule is only meant to be an indication of components that may fail prematurely (depending on use conditions) and is not a mandatory recommendation to replace properly functioning components. Ultimately it is the decision of the Administrative body for the clinical department to decide to replace properly functioning components as a preventative measure. The chart below details the components identified to be replaced and the time frequency.

Part Description	Part No.	*6	12	24	36
Ultra-Filter	20-0047				
Inlet solenoid assembly	59-0061				
Heatsan RO Membrane	R0124-0001				
RO Boost Pump	80-0280				
PCB Lithium battery	RR083349				

***6-month preventative maintenance schedule is based solely on heat disinfection**

CHEMICAL CLEANING AND HEAT DISINFECTION: In conjunction with the above guidance on preventative maintenance we recommend the unit is chemically cleaned and heat disinfected regularly in accordance with the guidelines located in **Section 8**.

9.2.1 Conductivity Calibration

The Centurion has been calibrated prior to shipment. However, the accuracy of the RO's permeate quality reading should be verified with a calibrated (traceable to NIST standards), hand-held conductivity meter at least annually. If the Permeate Quality displayed is not within 5% of the hand-held meter reading, the RO should be calibrated by following these procedures.

1. Allow the unit to run until the Permeate Quality is stable while the water is running to the drain.

2. Take a water sample from the product hose and test it with a hand-held conductivity meter.

3. Compare the meter results with the permeate quality displayed on the RO.

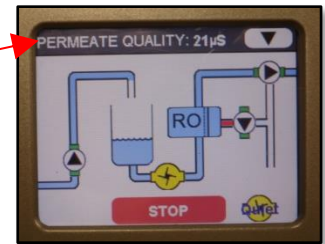

4. Press the Stop button so the Welcome Screen is displayed.

5. Press the Menu button.

6. Select Engineer Menu and press Enter.

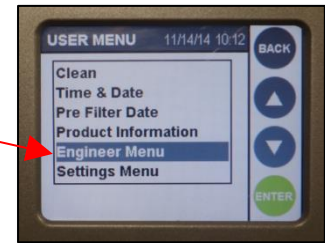

7. Enter the Pin number 9721 and press Next.

8. Select Setup and press Enter.

9. Select Calibration and press Enter.

10. Select Line Cell Constants and press Enter.

11. Select Permeate Line Cell and press Enter. The Permeate Line Cell has a default value of 0.65 and an acceptable input range from 0.05 to 1.00. Values set outside of this range will be ignored.

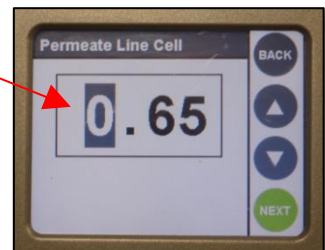

12. Increase or decrease the Permeate Line Cell in increments of .05 to increase or decrease the Permeate Quality.

13. When complete a "Done" message will appear.

14. Press the Back button until the Welcome Screen is displayed.

15. Repeat these procedures until the Permeate Quality displayed is within 5% of the hand-held meter reading. Log the calibration date in the facility's daily journal.

Note

1. The unit has no serviceable parts. Should one of the components identified as a spare part in **Sections 11.2.1 & 11.2.2** then refer to **Section 9.3** for details on how to remove and replace them.
2. If an item fails that is not listed in the above sections then contact **AmeriWater** for assistance.
3. **AmeriWater** will make available upon request any relevant circuit diagrams, component parts list, calibration instructions or other information necessary that will assist approved/trained service personnel to repair the equipment.

9.3 Unplanned minor maintenance and repairs

**Warning:**

1. It is advised that following any repair an electrical safety check on the unit should be carried out, Refer to **Section 9.1.1** for details.
2. When carrying out any repairs ensure that there is no risk to yourself, patients or bystanders.
3. Only carry out the repair if you are authorised and trained to do so.
4. Only use approved spare parts as detailed in **Section 11.2**.
5. Before using the equipment following any repair work always carry out the Pre-dialysis checks as detailed in **Section 9.6**.

9.3.1 Replacement of RO Membrane



(Spare Part no. R0124-0001)

Warning: The Reverse Osmosis (RO) membrane contains a preservative solution to prevent microbiological growth and freezing. Discard all product water for at least **two hours** of operation before placing the RO back into service. Failure to rinse out preservative may result in patient illness!

1. Stop the Centurion if the system is in operation.
2. Power down the Centurion using the switch on the rear of the RO.
3. Unplug the Centurion from the electrical supply and isolate the feed water supply from the RO.
4. Remove the left side (when viewed from front) panel using a small hex key and place the panel along with each of the screws in a safe location.
5. Place a rag around the bottom of the membrane before removing tubing connections to absorb water spilled from the membrane housing.
6. Remove each of the 4 tubing connections from the RO membrane by pressing the small release ring and pulling the tubing out. Water will drain from the bottom 2 ports. Excess water in the lower pan of the Centurion may be removed by removing the drain in the front of the unit and tipping the unit forward to allow the water to drain.

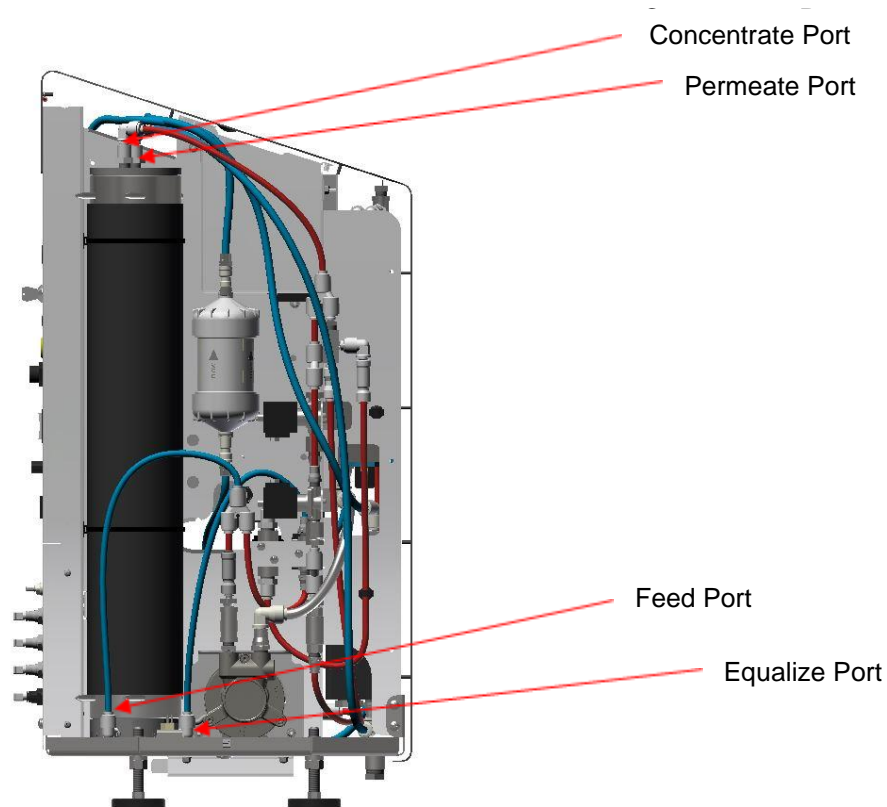

7. Carefully remove the cable ties securing the RO membrane using a small flat head screwdriver. These will be reused to reinstall the RO membrane. Replacement cable ties can be purchased under AMW PN 999-3648.
8. Remove the membrane housing from the Centurion once the cable ties have been removed.
9. With the membrane housing removed, note the top and bottom of the housing.
10. Remove the top and bottom membrane cap from the vessel by removing the U-Shaped pin from the vessel and carefully removing the cap. **DO NOT PULL ON THE PLASTIC FITTINGS TO REMOVE THE CAP.**
11. Remove the old membrane from the vessel. Note the orientation of the Brine seal in the vessel.
12. Clean all of the O-rings on the end caps and lubricate with a small amount of O-ring lubricant.
13. Unpack the new membrane (lubricant included in package) and lubricate the Brine seal. Insert the membrane into the feed side of the vessel with the Brine seal opening toward the feed (bottom) side of the vessel.

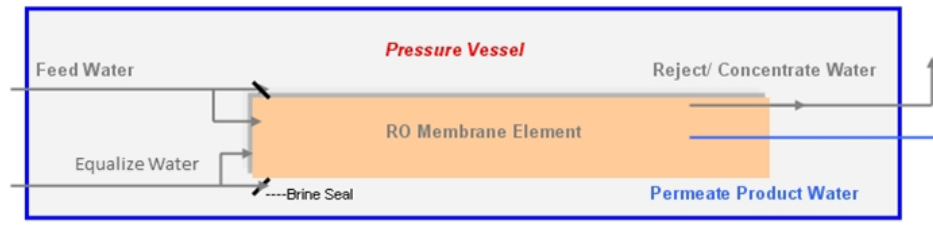

14. Reinstall the membrane vessel caps and U-shaped pins in the same location as they were removed.
15. Reinstall the membrane into the Centurion and secure the housing to the chassis using the existing cable ties.
16. With the membrane vessel reinstalled, power on the Centurion and reapply water to the system.
17. Navigate to menu>engineer menu>setup>boost pump speed>processing speed and turn the pump speed down to 50%.
18. Turn on the Centurion and allow the membrane to operate at low pressure for 5 minutes.
19. After 5 minutes, shut the Centurion off and return the boost pump speed to the factory default setting of 80% (return to previous value if not 80%).
20. Allow the Centurion to operate and discard the product water for the first 2 hours of operation in order to rinse all preservative out of the membrane.
21. Perform a Heat disinfection of the system before returning it to service and obtain a product water sample for AAMI analysis.

9.3.2 Replacement of RO boost pump

(Spare Part no. 80-0280)

1. Ensure unit is in **“Power On”** mode.
2. Turn the unit off by using the rear isolation rocker switch, ensure switch is in the **“O”** position and then isolate the unit from the electrical mains supply by removing the power cord from the wall socket or from the connection at the rear of the unit.
3. Turn off the incoming water supply to the unit.
4. Remove the left hand side cover and store safely.
5. Disconnect the 8mm tubing from the “tee” connector located on the outlet side of the pump head.

6. Disconnect the 12mm tubing from the inlet connector
(NB: you may require a suitable container to collect any water loss when disconnecting this tubing. Refer to **Section 14.1 “How to use the push-fit connectors”**, for details on how to remove tubing from the push fit connectors).
7. Unscrew the 4 off nuts located at the rear of the pump bracket that secure the bracket to the anti-vibration mounts.
8. Withdraw the pump and bracket assembly from the chassis until you can gain access to the pump power cord.
9. Remove the waterproof sleeve and disengage the white power cord connectors from one another.
10. To remove the pump, from the bracket unscrew the 4 off retaining bolts.
11. Refit the new pump to the bracket.
12. Slide the waterproof sleeving supplied with the new pump onto the power cord and reconnect. Ensure the sleeving completely covers the power cord connector blocks.
13. Locate the bracket back onto the anti-vibration studs and secure.
14. Remove the three red blanking plugs from the pump’s inlet/outlet and refit the water tubes.
15. To check the new pumps operation, with the side cover still removed, turn on the water supply and switch on the mains power supply to the unit by selecting the “**I**” position on the rear isolation switch.
16. Select “**START**”, the unit should run, it may require several restarts as the unit refills with water. Once running continuously checks around the water connections for any leaks.
17. Finally refit the side cover.
18. If required dispose of the pump according to the instructions in **Section 14.2 “E-Waste”**.

9.3.3 Replacement of inlet solenoid (S1)

(Spare Part no. 59-0061)

1. Ensure unit is in “**Power On**” mode.
2. Turn the unit off by using the rear isolation rocker switch, ensure switch is in the “**O**” position and then isolate the unit from the electrical mains supply by removing the power cord from the wall socket or from the connection at the rear of the unit.

3. Turn off the incoming water supply to the unit.
4. Remove the right hand side cover (when looking from front of unit) and store safely.
5. Locate the inlet valve (see below) and remove the solenoid coil by unscrewing the central retaining screw.

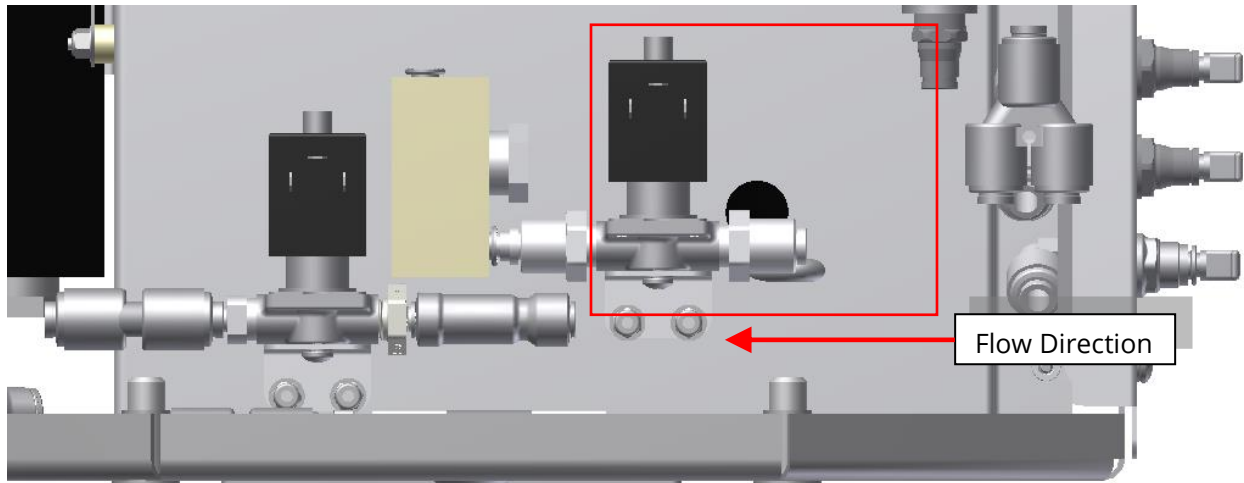

6. Next remove the valve support bracket from the main chassis by unscrewing the two securing bolts located underneath the valve.
7. Remove the support bracket from the valve.
8. With the aid of the tubing release tool disengage the inlet and outlet tubing from the valve fittings.
9. Reconnect the tubing to the new valve assembly making sure the valve is fitted in the correct flow direction.
10. Re-attach the support bracket and reinstall the assembly on the main chassis.
11. To check for leaks reinstate the power and water supplies and run the unit for at least 15 minutes. If satisfactory, replace the side cover.
12. Refer to **Section 14.2** for disposal of the valve.

9.3.4 Replacement of drain valve solenoids #1 (S4) & #2 (S5))

(Spare Part no. Drain Valve #1:- 59-0061
 Drain Valve #2:- 59-0061)

1. Ensure unit is in “**Power On**” mode.

2. Isolate from mains power supply using the rear isolation rocker switch, ensure switch is in the “O” position.
3. Turn off the incoming water supply to the unit.
4. Locate the Drain valves (see below) and remove the solenoid coil by unscrewing the central retaining screw.

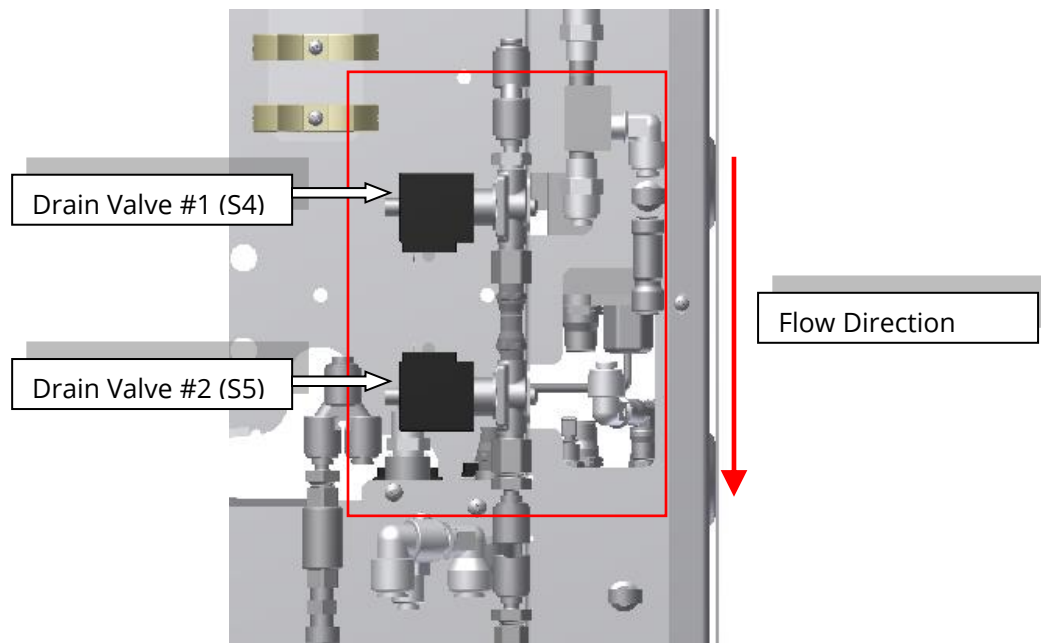

5. Unscrew valve from bracket and remove associated tubing.
6. Replacement is the opposite of removal.

9.3.5 Replacement of the chemical draw valve (S3)

(Spare Part no. 59-0062)

1. Ensure unit is in “**Power On**” mode.
2. Isolate from mains power supply using the rear isolation rocker switch, ensure switch is in the “**O**” position.
3. Turn off the incoming water supply to the unit.
4. Locate the Chemical Draw Valve (S3) (see below) and remove the solenoid coil by removing the central retaining screw.

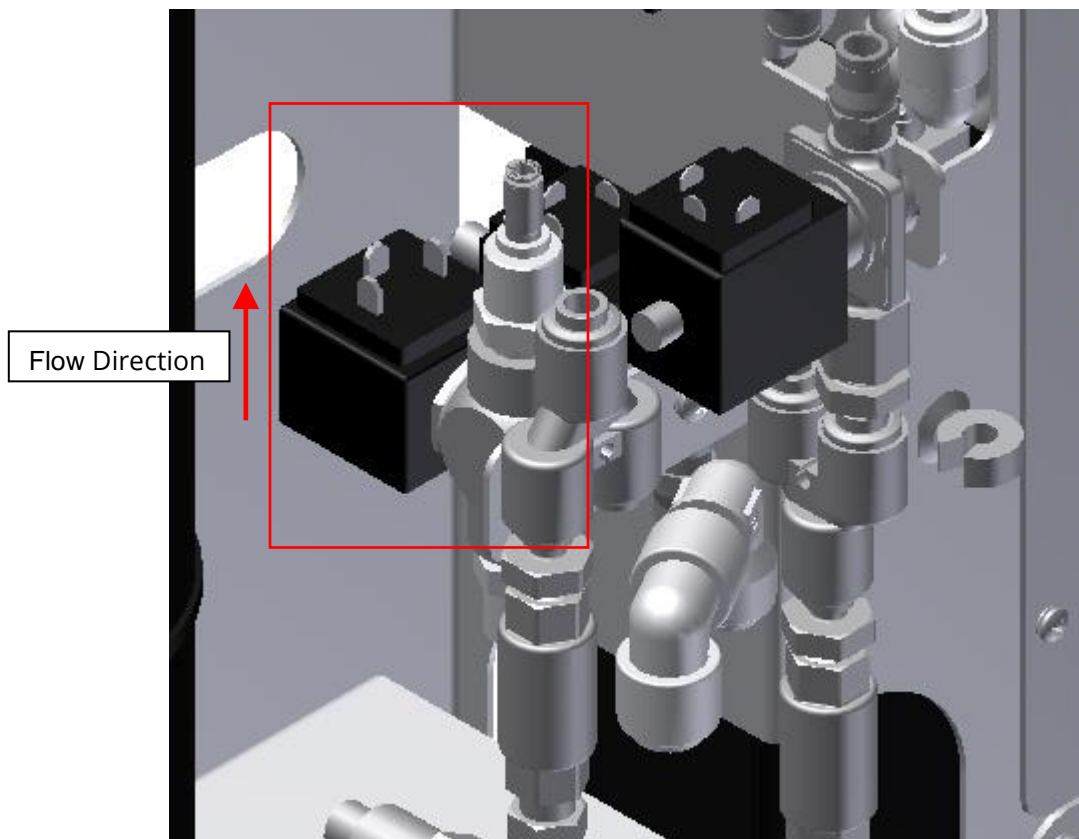

5. Unscrew the valve body from the bracket and remove any tubing associated.
6. Installation is the reverse of removal.

9.3.6 Replacement of the permeate valve (S2)

(Spare Part no. 59-0062)

1. Ensure unit is in “**Power On**” mode.
2. Turn the unit off by using the rear isolation rocker switch, ensure switch is in the “**O**” position and then isolate the unit from the electrical mains supply by removing the power cord from the wall socket or from the connection at the rear of the unit.
3. Turn off the incoming water supply to the unit.
4. Remove the right hand side cover (when looking from front of unit) and store safely.
5. Locate the inlet valve (see below) and remove the solenoid coil by unscrewing the central retaining screw.

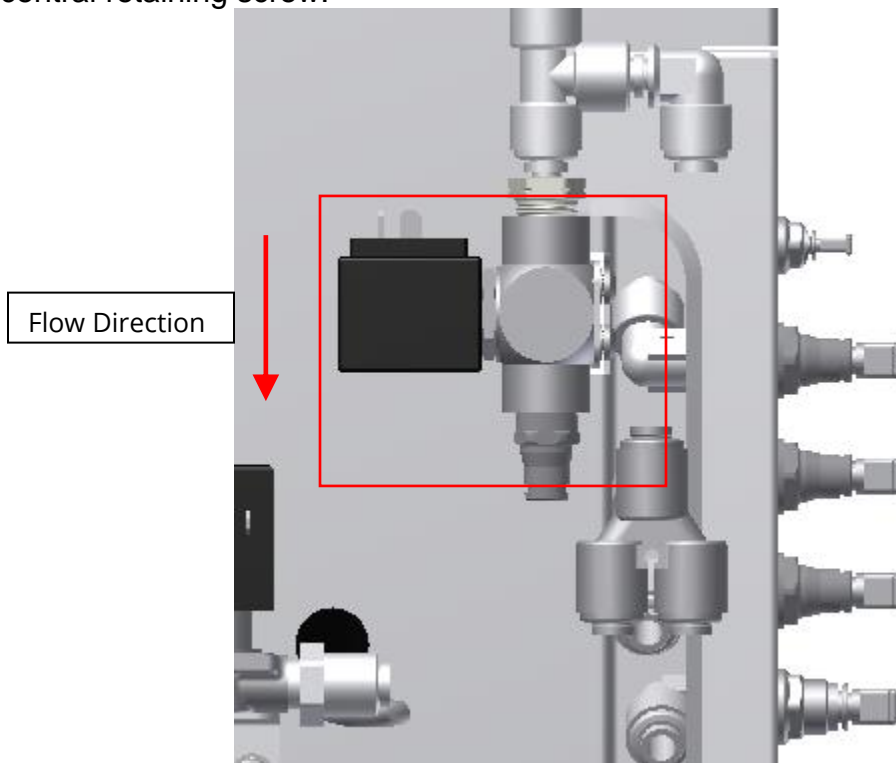

6. Unscrew the valve from the support bracket.
7. With the aid of the tubing release tool disengage the inlet and outlet tubing from the valve fittings.
8. Reconnect the tubing to the new valve assembly making sure the valve is fitted in the correct flow direction.
9. Installation is the reverse of removal.
10. To check for leaks reinstate the power and water supplies and run the unit for at least 15 minutes. If satisfactory, replace the side cover.

9.3.7 Replacement of the blend valve (S7)

(Spare Part no. R59-0008)

1. Ensure unit is in “**Power On**” mode.
2. Turn the unit off by using the rear isolation rocker switch, ensure switch is in the “**O**” position and then isolate the unit from the electrical mains supply by removing the power cord from the wall socket or from the connection at the rear of the unit.
3. Turn off the incoming water supply to the unit.
4. Remove the right hand side cover (when looking from front of unit) and store safely.
5. Locate the inlet valve (see below) and remove the solenoid coil by unscrewing the central retaining screw.

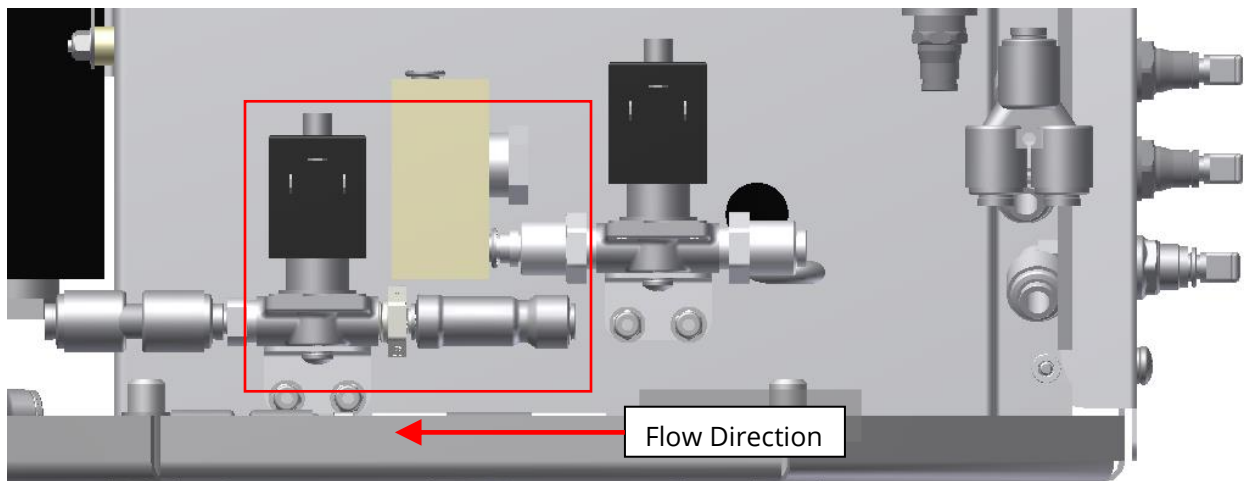

6. Next remove the valve support bracket from the main chassis by unscrewing the two securing bolts located underneath the valve.
7. Remove the support bracket from the valve.
8. With the aid of the tubing release tool disengage the inlet and outlet tubing from the valve fittings.
9. Reconnect the tubing to the new valve assembly making sure the valve is fitted in the correct flow direction.
10. Re-attach the support bracket and reinstall the assembly on the main chassis.
11. To check for leaks reinstate the power and water supplies and run the unit for at least 15 minutes. If satisfactory, replace the side cover.

9.3.8 Replacement of the equalize valve (S6)

(Spare Part no. 59-0061)

1. See section 9.3.5

9.3.9 Replacement of the turbine flow sensor

(Spare Part no. 41-0052)

1. Ensure unit is in “**Power On**” mode.
2. Turn the unit off by using the rear isolation rocker switch, ensure switch is in the “**O**” position and then isolate the unit from the electrical mains supply by removing the power cord from the wall socket or from the connection at the rear of the unit.
3. Turn off the incoming water supply to the unit.
4. Remove the left hand side cover.
5. Locate the flow sensor (see below) and remove the electrical connector by unscrewing the central retaining screw.

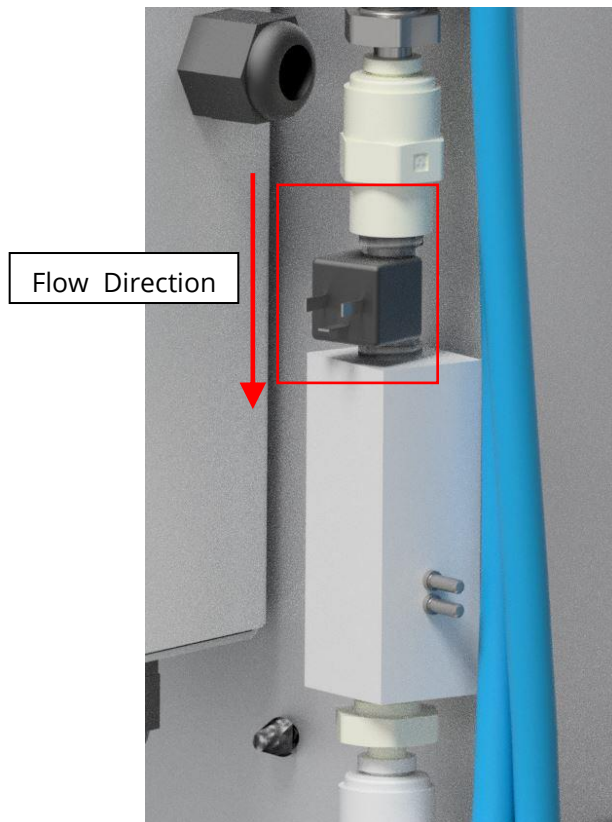

6. With the aid of the tubing release tool disengage the inlet and outlet tubing from the flow sensor fittings.

7. Reconnect the tubing to the new assembly making sure the sensor is installed in its correct flow direction.
8. To check for leaks reinstate the power and water supplies and run the unit for at least 15 minutes. If satisfactory, replace the side cover.
9. Refer to **Section 14.2** for disposal of the old assembly.
10. There is no requirement to re-calibrate the new flow sensor.

9.3.10 Replacement of Internal electrical box fuses

(Spare Part no. RR082006)

Note: It is advised that irrespective of which fuse has failed that both fuses are replaced at the same time.
--

1. Ensure unit is in “**Power On**” mode.
2. Turn the unit off by using the rear isolation rocker switch, ensure switch is in the “**O**” position and then isolate the unit from the electrical mains supply by removing the power cord from the wall socket or from the connection on the rear of the unit.
3. Turn off the incoming water supply to the unit.
4. Remove the left hand side cover.
5. Locate the fuses (see drawing).
6. To remove a fuse from its holder simply unscrew the black cap by inserting a suitably sized flat ended screwdriver into the slot on the fuse holder cap and turning anti-clockwise. Once fully unscrewed withdraw the holder to expose the small cartridge type fuse.
7. Remove the fuse from its holder and replace with a new one, always check that the replacement fuse is off the correct rating. See **Section 12.1.2** for details of fuse ratings. Repeat for the second fuse.
8. When both fuses have been replaced refit the side cover. If the initial fault still persists refer to **Section 10.0**.

9.3.11 Replacement of the external fuses

(Spare Part no. 63-0045)

1. Ensure unit is in “**Power On**” mode.
2. Turn the unit off by using the rear isolation rocker switch, ensure switch is in the “**O**” position and then isolate the unit from the electrical mains supply by removing the power cord from the wall socket or from the connection on the rear of the unit.
3. Turn off the incoming water supply to the unit.
4. Locate the fuses (see drawing).
6. To remove a fuse from its holder simply unscrew the black cap by inserting a suitably sized flat ended screwdriver into the slot on the fuse holder cap and turning counter clockwise. Once fully unscrewed withdraw the holder to expose the small cartridge type fuse.
7. Remove the fuse from its holder and replace with a new one, always check that the replacement fuse is off the correct rating. See **Section 12.1.2** for details of fuse ratings. Repeat for the second fuse.
8. When both fuses have been replaced check the operation of the unit. If the initial fault still persists refer to **Section 10.0**.

Location of external fuses

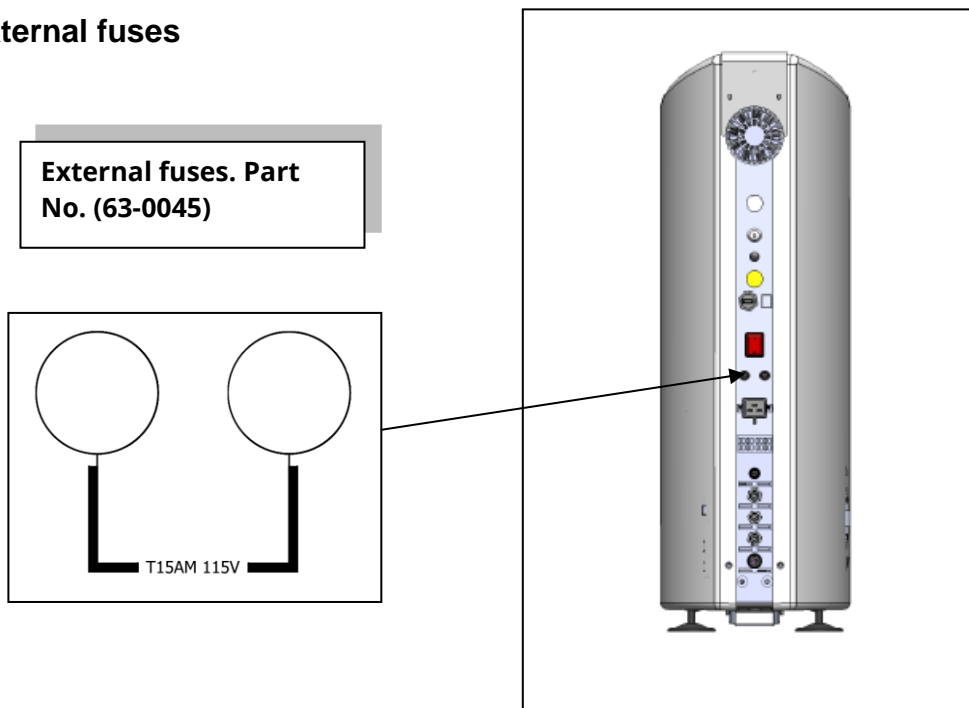

9.3.12 Replacing the main PCB lithium battery

(Spare Part No. RR083349)

Note: The battery has a five year life, but **AmeriWater** recommend that it is replaced every three years.

1. Ensure unit is in “**Power On**” mode.
2. Turn the unit off by using the rear isolation rocker switch, ensure switch is in the “**O**” position and then isolate the unit from the electrical mains supply by removing the power cord from the wall socket or from the connection on the rear of the unit.
3. Turn off the incoming water supply to the unit.
4. The battery is located within the main PCB which is accessed via removal of the right hand side cover. (See “*location of main PCB and Lithium battery diagram*”)
5. Using a Phillips screwdriver remove the retaining screws that secure the lid of the electrical box.
6. Once removed the battery can be clearly seen on the main PCB, prise the battery out of its holder.
7. Refit the new battery ensuring the, (+) positive side is facing upwards, the battery should be pressed gently until the four clamps in the retainer “snap” over the battery fully. Refer to **Section 12.1.3** to check details of battery before fitting.
8. Dispose of the old battery according to guidelines in **Section 14.2**.
9. Refit electrical box cover and right hand side cover.
10. Reinststate the mains power supply and check the operation of unit.



Warning:

Incorrect fitting of the battery could cause irreversible damage to the main PCB. Ensure the **(+) positive** side of the battery is facing upwards. Always use the recommended battery, Part No. RR083349. The battery has a five year life, but **AmeriWater** recommend that it is replaced every three years.

Location of Main PCB and Lithium battery diagram

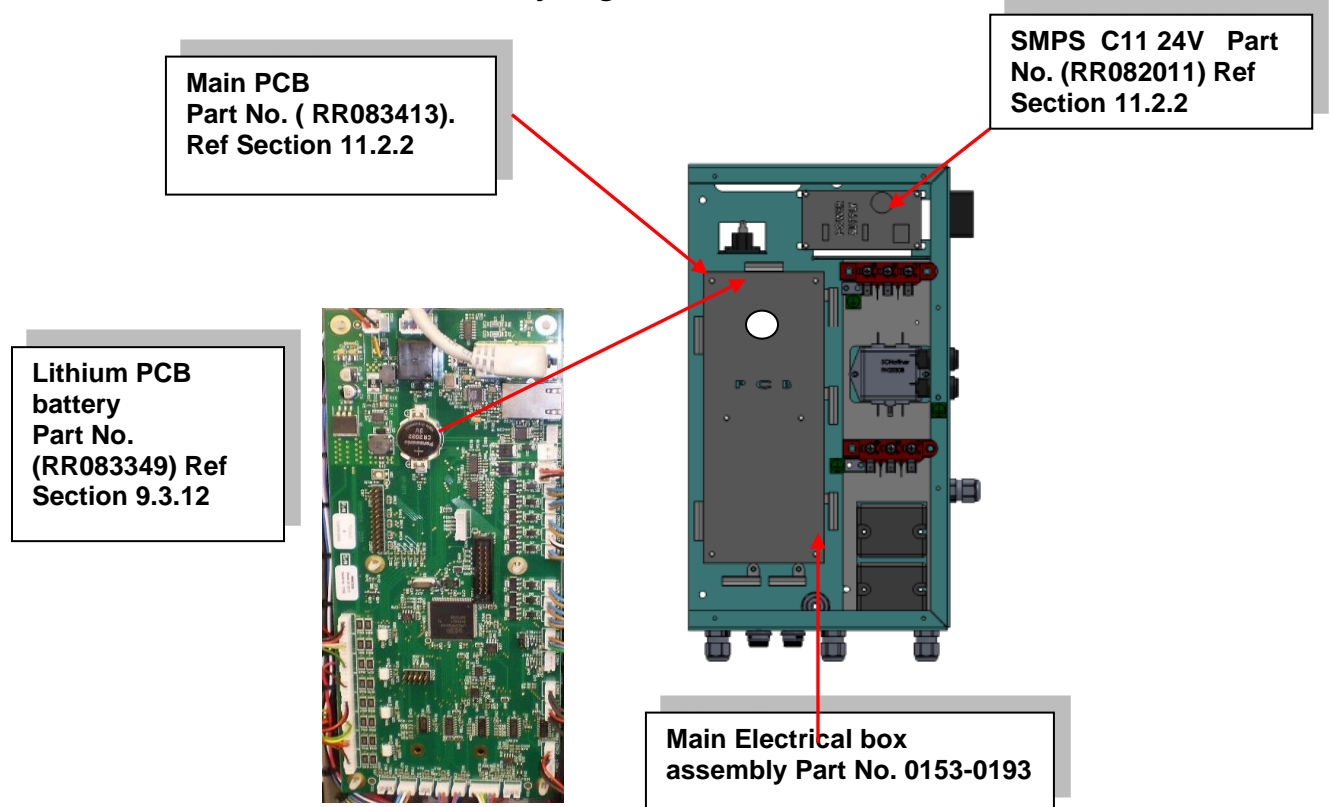

9.3.13 Uploading new software

Note: Record all system settings before uploading new software.

1. With power applied to the unit, disable any Standby options that may be selected as Enabled (Make a note of the original selections so they can be restored after programming):
 - a. Select MENU – Standby – Power On – ENTER. Select the Disabled option if not already selected – ENTER
 - b. Select – Timed – ENTER. Select the Disabled option if not already selected – ENTER
2. With the power to the unit removed, connect the Memory Stick loaded with the appropriate three files into the units USB connector. This connector is located on the rear panel.
3. Apply mains power to the unit and select MENU–System Menu–Data Transfer–Clear Logger–ENTER–YES. Press the BACK button until the POWER-ON / WELCOME screen is displayed.

4. Select MENU–Systems Menu-Engineer Menu (enter PIN)–Software Update

- a. Select Update Display–ENTER-YES. The Display file should now start loading.
- b. When the POWER-ON / WELCOME screen is displayed (ignore any ‘Communication Error’ message), remove the mains power from the unit.
- c. After approximately 10 seconds re-apply the power.

5. Select MENU–Systems Menu-Engineer Menu (enter PIN)–Software Update.

Select Update GUI–ENTER-YES. The Graphic files should now start downloading. When the POWER-ON / WELCOME screen is displayed (ignore any ‘Communication Error’ message), remove the mains power from the unit.

After approximately 10 second re-apply the power.

6. Select MENU–Systems Menu-Engineer Menu (enter PIN)–Software Update.

- a. Select Update Controller–ENTER-YES (Note: this file will take several minutes to load).
- b. When the POWER-ON / WELCOME screen is displayed (ignore any ‘Communication Error’ message), remove the mains power from the unit.

7. Wait approximately 10 seconds then remove the Memory Stick from the unit.

8. Apply mains power to the unit.

Check that the correct files have successfully loaded:

- a. Select MENU–System Menu-Product Information
- b. Check that the data presented in the following fields matches the data on the relevant Software Release Note.
TYPE:
UNIT VERSION:
POD VERSION:
MEMORY CHECKSUM

9. Press the BACK button several times until the POWER-ON / WELCOME screen is displayed. The re-programming is now complete.

10. If necessary, re-enable the Standby options that have been Disabled as appropriate:

- a. Select MENU – Standby – Power On – ENTER. Select Enabled, if previously enabled – ENTER
- b. Select MENU –Timed – ENTER. Select Enabled, if previously enabled – ENTER

11. Press the BACK button several times until the POWER-ON / WELCOME screen is displayed
12. After the software update is complete, verify that the default settings match the setting recorded before the update. If default settings need to be reloaded, select MENU–Systems Menu-Engineer Menu (enter PIN)–SETUP-COMMISSION SETUP-RESTORE DEFAULTS
 - a. Select the BACK button and enter the time and date.
 - b. Shut down and restart the Centurion.
 - c. Select MENU–Systems Menu-Engineer Menu (enter PIN)
 - d. Load the factory default settings found in section 7.5.
13. Press the BACK button several times until the POWER-ON / WELCOME screen is displayed.

9.3.14 Removing and replacing the main lead

Spare Part No. (Non-fixed installation) 66-0181

1. For fixed installation a qualified electrician must disconnect the lead from the wall socket. For non-fixed installations the lead is supplied with a plug which can be simply disconnected from the wall socket. The procedure below relates to (Fixed installation).
2. Switch the unit off using the rocker switch at the rear of the unit and isolate from the mains supply via circuit breaker or other isolation device.
3. Turn off the water supply.
4. To disconnect the plug end at the unit unscrew the securing connecting clamp. Once unscrewed pull away the plug.
5. Push the plugged end of the new lead into the rear socket on the unit. Attach the clamping device and secure by tightening the two retaining screws. When secure gently pull on the cord to ensure it is fully retained.
6. Re-wire the other end of the lead into the wall socket.
7. Before operating the unit an electrical integrity check should be carried out to check the safety of the unit.

9.4 Location of spare parts

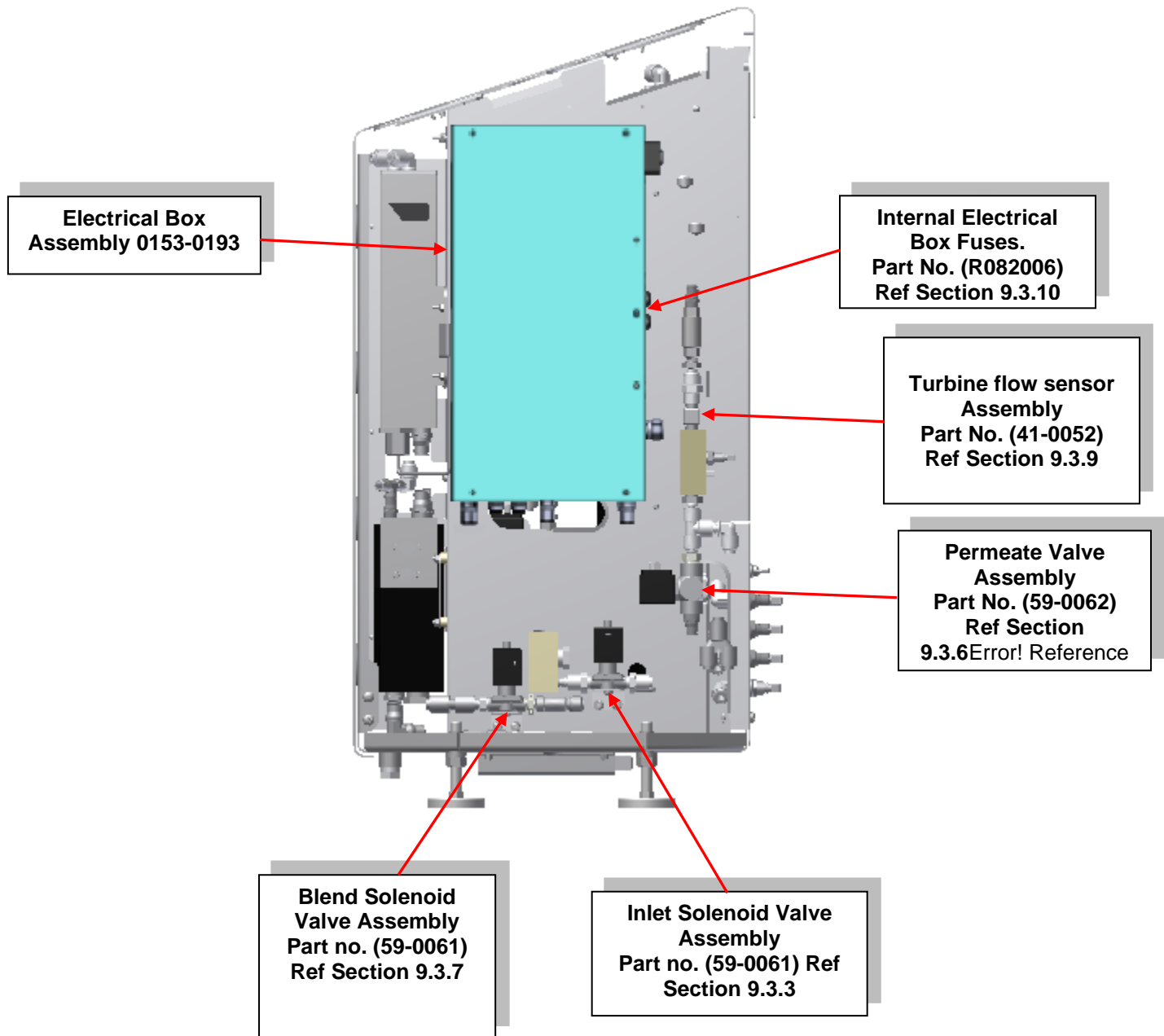

(Right hand side view of Centurion by AmeriWater)

Location of spare parts.....Continued

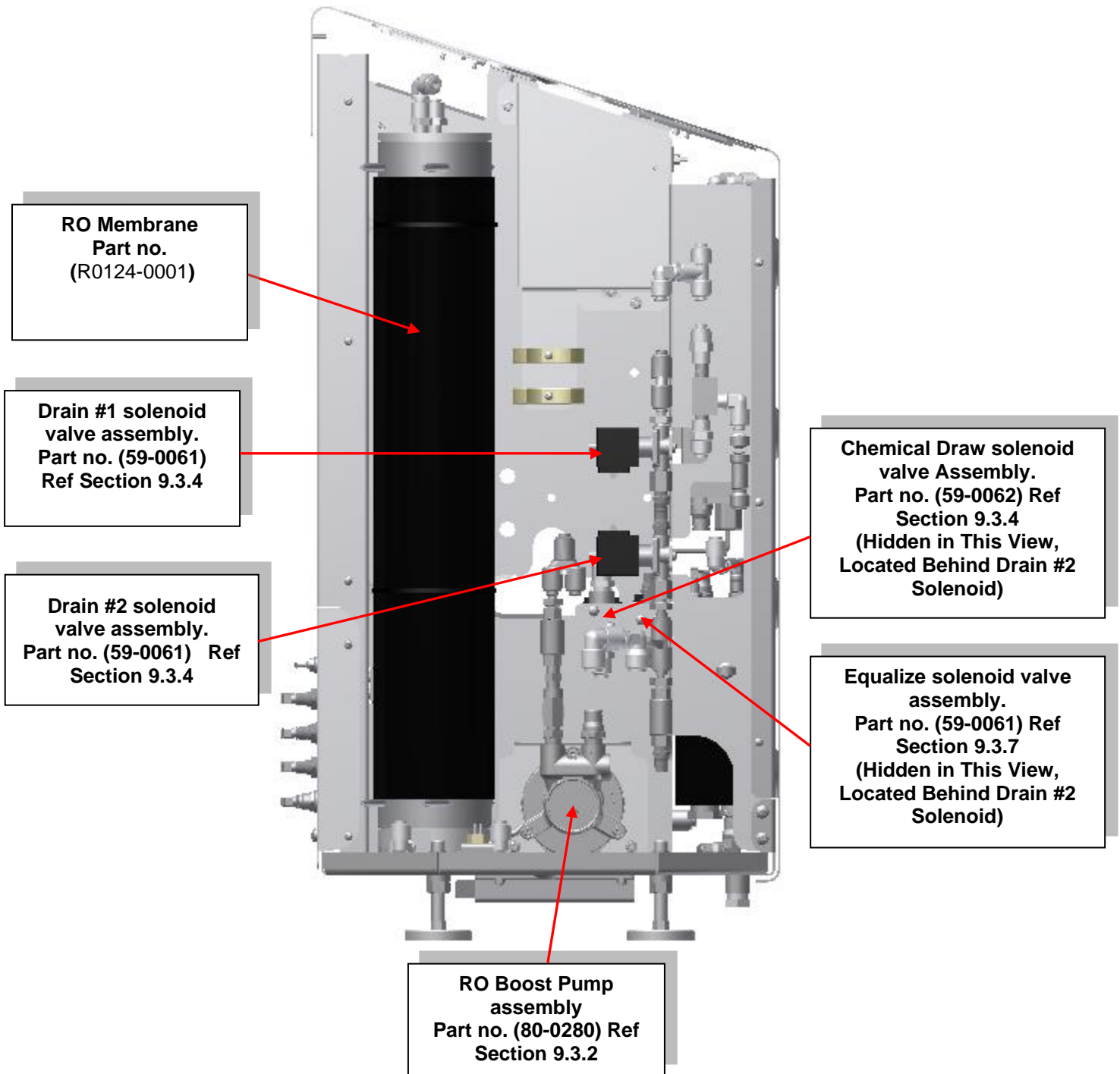

(Left hand side view of Centurion by AmeriWater)

9.5 Replacement of consumables

9.5.1 Removal and replacement of the Ultra-filter

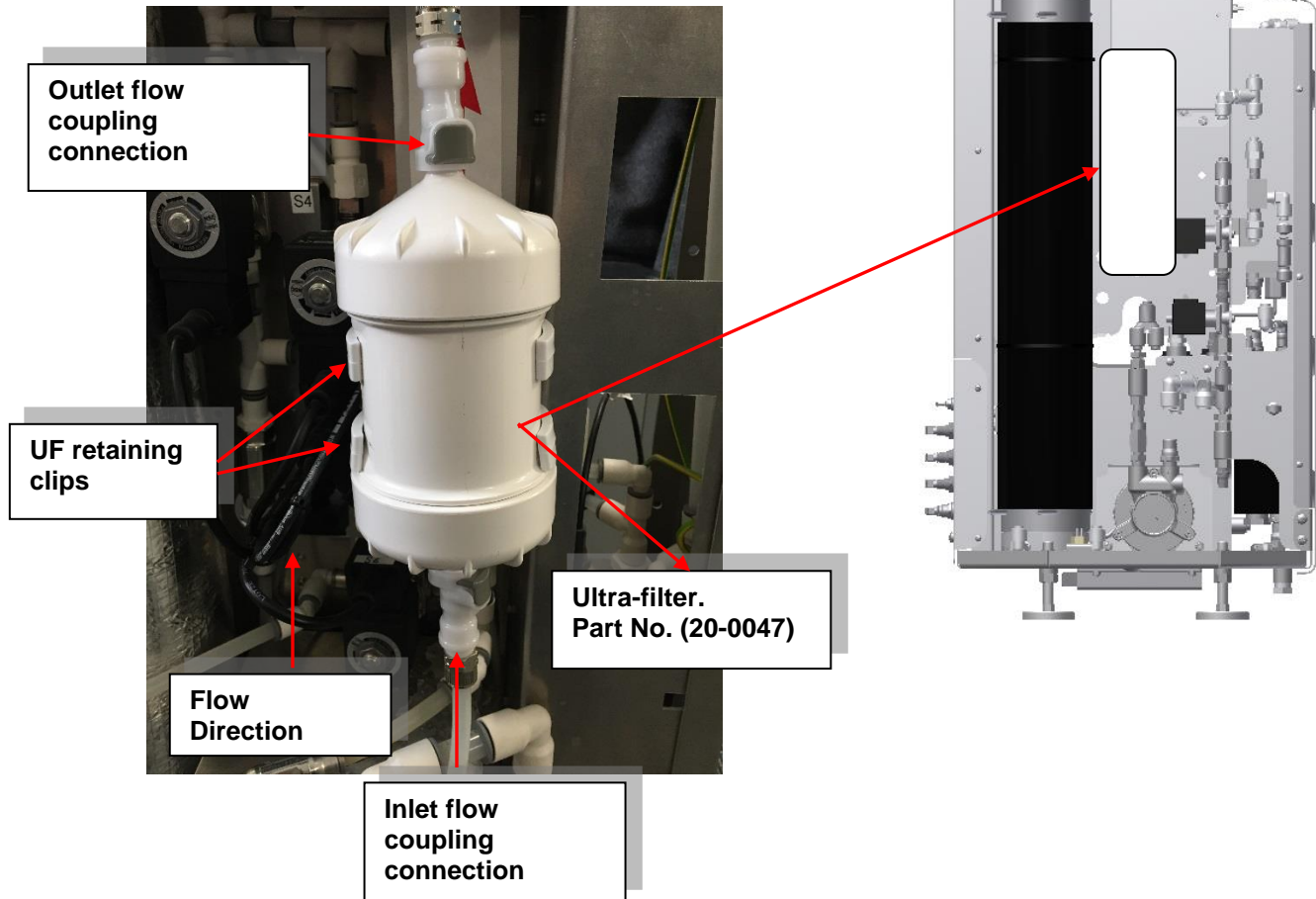

1. Ensure unit is in **“Power On”** mode.
2. Turn the unit off by using the rear isolation rocker switch, ensure switch is in the **“O”** position and then isolate the unit from the electrical mains supply by removing the power cord from the wall socket or from the connection on the rear of the unit.
3. Turn off the incoming water supply to the unit.
4. Remove the left hand side cover by removing the two rear retaining screws.
5. Gently pull the Ultra-filter from the two white retaining clips and move away from the unit.
6. Disconnect the inlet and outlet flow couplings by pushing the grey button and pulling away from the filter.

Note: There will be some water loss from the Ultra-filter as it is disconnected so ensure you have a suitable container to collect any spillages.

7. Dispose of the used Ultra-filter device in accordance with local disposal requirements.
8. Remove the new Ultra-filter element from its packaging and place filter in bracket. There will be two small blue caps contained with the new filter. DO NOT discard these as they are used to cap the filter when cleaning the RO.
9. Reconnect the outlet coupling first followed by the inlet coupling.
10. Reinststate the water and power supplies to the unit. Restart the unit and run permeate to the drain for 2 minutes to purge the filter of air. Allow the RO to run for 10-15 minutes to check for leaks.
11. If there are no leaks refit the side cover.

Note: When handling the new Ultra-filter element we recommend the wearing of protective gloves to prevent any contamination.

Never use hand sanitizer before handling the Ultra-Filter.

Following installation of the new filter we recommend that the unit is heat sanitised.

9.5.2 Consumable replacement frequency

The Ultra-filter should be replaced after 26 disinfection cycles. Reference **Section 8.4** for more information on the life of the filter.

9.6 Pre-Dialysis checks

Following any repair/servicing, maintenance or prior to each dialysis session or following storage of the unit it is recommended that the following checks are carried out

- Check that the electrical mains lead is securely clipped in place on the unit and at the wall socket and that the lead is not damaged or likely to cause anyone to trip over it.
- All the water connections are in place, not kinked and show no signs of leaks.
- The “**Blue**” water tubing is connected to the “**In/Entree**” port, the “**Black**” water tubing is connected to the “**Drain**” port.
- The water supply is turned on.

- There are no warning messages displayed on the touch-screen. (Refer to **Section 10.0, “Troubleshooting”** if any messages are displayed.
- The unit sounds and runs quietly, if the unit sounds un-usually noisy or you are concerned about its operation refer to **Section 10.0 “Troubleshooting”** for guidance.
- The unit has been signed off as safe for use by an approved person.
- There are no signs of any leaks.



Warning:
Do Not start dialysing if the unit appears to have a fault.

9.7 Cleaning external surfaces

Use a clean damp cloth to wipe the exterior surface of the unit. Take care not to get excess liquid on the control panel areas.

Isopropyl alcohol in a 70% concentration or less (on a towel or pre-wetted wipes) is an acceptable surface disinfectant for the external surfaces of the Centurion. Contact **AmeriWater** before using any other solvents on external surfaces.

Take the necessary precautions when wiping up any bodily fluids.

Note: The unit has an IP rating =21, refer to **Section 12.1.4** for details

9.8 Storage and preservation recommendations

Use the guide below to determine the best method to store your unit if it is not be used for any length of time.

Note: To reduce the risk of water loss if the unit is to be left unattended without the standby option enable it is advised to turn off the incoming water supply and isolate the unit from the mains electrical supply by either removing the power cord from the wall socket or disconnecting at the rear of the unit.

Time not in use		Recommendations
Up to 1 month	Short term storage	Ideally the unit should be left in Power-On Standby mode such that it will run for 10 minutes every 2 hours. If the unit is to be left ensure the room temperature does not fall below freezing point, 32°F. On starting the unit up after standing run for 10 minutes disconnected from the dialysis machine and carryout a heat disinfection.
>1 month up to 3 months	Medium	Either maintain the unit in the mode above or decommission and preserve the unit with 10%w/v Sodium metabisulphite solution. Before use ensure that the preservative has been fully rinsed out. Following rinsing of the preservative solution carryout a heat disinfection cycle.
>3 months- 6 months+	Long Term	If the unit cannot be operated above then it is recommended that the following storage /preservation procedure is applied. <ol style="list-style-type: none"> 1. Run preservative solution through the unit then drain the unit fully. 2. Remove the RO membrane 3. Remove the UF filter (if fitted) 4. Seal the unit in a plastic bag and store in its original packaging (if present) 5. When the unit is recommissioned refit new RO membrane/UF, run for 1 hour and then perform a heat sanitisation cycle. 6. Carry out electrical safety check (see Section 9.1.1).

10.0 TROUBLESHOOTING

**Warning:**

There are several safety features built into the controls of the unit and they are designed to protect the unit from damage and to warn of any malfunction.

Pay attention to warning messages and follow the instructions, warnings, cautions and notes given in this manual.

If the unit develops a fault, follow the instructions in **Section 6.2.3** to shut the unit down safely and in a controlled manner.



In the event of an emergency follow the instructions in **Section 3.7** to shut the unit down quickly.





Once the unit has been safely shut down and the water supply turned off, make a note of any messages that were displayed on the screen as these may be helpful in diagnosing the fault.







If the fault cannot be rectified or is outside the scope of this manual then refer to **AmeriWater** or their local approved distributor for advice.





10.1 Troubleshooting Guide



10.1.1 Warning & alarm messages (Processing Mode)





Displayed Message or notification	Reason	Checks	Proposed Actions
 "Tank Low Level"	The internal water break tank has insufficient water to run the unit.	<ol style="list-style-type: none"> 1. Make sure the feedwater supply is turned, flowing and within the pressure range specified. 2. Check for restriction in the inlet solenoid or flow restrictor up stream of the break tank. 	<ol style="list-style-type: none"> 1. If the feedwater supply is not a problem and the unit still does not run due to insufficient make up flow, remove and check the inlet solenoid and flow restrictor for any possible restrictions.
 "High Pressure" 	<p>-The unit has detected a pressure of 15 bar for 3 seconds during processing.</p> <p>-The unit has detected a pressure of 3.5 bar for 3 seconds while the equalize solenoid is active during heat disinfection.</p> <p>-The unit has detected a pressure of 15.0 bar for 3 seconds while the equalize solenoid is inactive during heat disinfect</p> <p>-The unit has detected a pressure of 15.0 bar for 8 seconds during chemical cleaning</p>	<ol style="list-style-type: none"> 1. Check for restrictions in the flow path and ultra-filter 2. Check that the pump speed is set to 80% during PROCESSING. 3. Check that P8-RO Feed check valve functions properly. 4. Check that water is flowing to the drain during operation. 5. Check that P9-Permeate check valve functions properly. 6. Be sure the set screw on the RO Pump has not been adjusted. 7. Check that the RO membrane does not have excessive scaling 8. Check that the Pressure Transducer E9 provides an accurate reading. 	<ol style="list-style-type: none"> 1. DO NOT try to run the unit in this condition. If the issue persists after the following checks, contact AmeriWater for assistance. 2. Attempt to reduce the pump speed during processing. If this solves the issue, continue diagnosing the cause of the pressure increase 3. Remove P8 and check for blockage. Test to make sure the valve opens and closes without resistance. 4. If water is not flowing to the drain, test drain solenoid S5. A solenoid which has failed close will cause excessive pressure. 5. Remove check valve P9. Test the valve opens and closes without resistance. 6. Moving the set screw on the RO Pump will cause pressure to become uncontrolled. 7. Perform an acid & base cleaning on the RO to remove scale and buildup on the membrane. 8. Using a pressure gauge, manually check the pressure on the pump outlet.



	“Low Pressure”	<p>The unit has detected a pressure of less than 1 bar for 10 seconds during all phases of operation.</p>	<ol style="list-style-type: none"> 1. Check that the feedwater is still flowing. 2. Check that there are no leaks. 3. Check for any other messages on the display. 4. Check that the pump motor is running 5. Check that the Pressure Transducer E9 provides and accurate reading 6. Check that the set screw on the RO Pump has not been adjusted 	<ol style="list-style-type: none"> 1. Check that the feedwater meets the requirements listed in this manual. 2. Fix any leaks found in the unit, especially around the pump. 3. If the pump motor is not running, make sure there is power to the pump. If there is power, replace the RO Pump. 4. Using a pressure gauge, manually check the pressure on the pump outlet. 5. Moving the set screw on the RO Pump will cause pressure to become uncontrolled. 6. If the checks do not show any problems, press the “Start” button after a few minutes, if the pressure in unit has returned to normal the unit will run. If the message returns then switch the unit off, turn off the water supply and contact AmeriWater for advice.
				
	“Perm-Line Cell Error”	<p>The unit has detected a fault with the meter measuring the water quality. The a/d converter is reading a maximum value.</p>	<ol style="list-style-type: none"> 1. Check that the Permeate line cell E18 is not disconnected. 	<ol style="list-style-type: none"> 1. Verify that the permeate line cell connected to CON11 on the main control board. 2. Check that the Permeate line cell cable is not disconnected from the sensor.
	“Temperature High”	<p>The water being produced has a temperature above the entered set point (default of 95 Deg F)</p>	<ol style="list-style-type: none"> 1. Check the temperature of the incoming water supply. 2. Check that the unit is not next to a source of heat, eg, radiator or room heater. 3. Check that the unit is in “Processing” mode. 4. Check that the temperature set point in the Engineering menu has not been altered. 5. Check the resistance of the thermistors 	<ol style="list-style-type: none"> 1. If the feedwater has a high temperature, investigate or change supply. 2. Remove any local external heat source. 3. Navigate to the alarm set point menu and verify that the set point is 95 F 4. Verify the thermistor resistance is 10kΩ ± 5%

	“Temperature Sensor Error”	There is a fault with the temperature sensor.	<ol style="list-style-type: none"> 1. Make a note of any other messages displayed on the screen. 2. Check that the temperature sensor E4 is connected and no wires are broken. 	<ol style="list-style-type: none"> 1. The unit MAY be operated in processing for treatment. Contact AmeriWater to obtain a replacement sensor before performing the next Heat Disinfection.
	“Level Switch Error”	The unit has detected a problem with the level sensors in the internal water break tank.	<ol style="list-style-type: none"> 1. Ensure the unit has no other displayed messages. 2. Check the unit is level and not tilted over. 3. Check that all 3 level floats move freely. 	<ol style="list-style-type: none"> 1. To prevent the possibility of water leakage due to the internal tank overflowing for safety it will have stopped running. 2. No other warning messages are displayed and the unit appears to be as normal but the problem persists, call AmeriWater for assistance.
	“Water leak”	5	<ol style="list-style-type: none"> 1. The unit has developed an internal leak, check that the unit is upright and level and has not been recently toppled or knocked. 2. Check to see if water is leaking from the unit at a constant rate. 3. Check for excessive feedwater pressure causing splashing. 	<ol style="list-style-type: none"> 1. If the unit has been toppled some water may have overflowed from the internal water break tank. Drain the water off from the unit. At the front underside of the unit is a black drain plug, unscrew the plug and let any water drain from the unit Then press “Start”. 2. Clean and dry the area surrounding the sensor once the leak has been resolved. Temporarily disconnecting CON12 from the main PCB will disable the leak detection cell. 3. If the unit is losing a lot of water turn of the water supply and contact AmeriWater for assistance.
				
	“Tilt”	The unit has been moved or knocked whilst running to such an extent that the internal tilt switch has been activated.	<ol style="list-style-type: none"> 1. Check that the unit is upright and standing on a firm flat surface. 2. Make sure that there is nothing located near the unit that might knock it . 3. Check that the unit is not placed next to a door or could be knocked over by children or pets. 	<ol style="list-style-type: none"> 1. Drain any excess water from the unit. Switch the power On then Off to clear the alarm. If the alarm persist after the unit is upright, continue to step 2. 2. Check that the tilt switch E1 has not failed “open” by removing the connectors and testing for continuity across the sensor. If there is no continuity, the sensor has failed or is stuck “open”.
				

	“Reset Error”	The unit has switched on and off more than 3 times in one minute.	<ol style="list-style-type: none"> 1. Make sure the mains electrical lead is secure at the connection to the unit at the wall socket. 2. Check that you're household circuit breaker has not tripped out or has a fault. 3. Are you experiencing power cuts to your property? 4. Is the unit being serviced and the Engineer has switched the unit off many times to repair a fault. 	<ol style="list-style-type: none"> 1. Ensure that the mains electrical lead is secure and fixed. 2. Check the condition of your circuit breaker and any other household appliances being used. This may have to be carried out you're your Healthcare provider. 3. Check with your local power company if they are experiencing any power losses in your area. 4. To clear the alarm, shut the Centurion off for 2-3 minutes. Turn the unit back on and the alarm should be cleared.
	“Feed-Line Cell Error”	The unit has detected a fault with the line cell used to measure the quality of the incoming feedwater supply.	<ol style="list-style-type: none"> 1. Check that the line cell E17 has not become disconnected 2. Check that CON10 on the control board provides an accurate signal. 	<ol style="list-style-type: none"> 1. Contact AmeriWater and give them the details of all messages displayed in order for them to diagnose the problem and advise you if the unit can be operated with this fault. 2. Check that line cell E17 is plugged into CON11 on the control board. 3. Test another line Cell E17 if possible.
	“Clean Due”	The time period set by your Healthcare provider for the next chemical clean has expired and the unit now requires a chemical clean.	No checks required.	If you are trained and approved to do so carryout a chemical clean on the unit at the next convenient time.
	“HeatSan Due”	The time period set by your Healthcare provider for the next Heat disinfection has expired and the unit now requires full heat disinfection.	No checks required.	If you are trained and approved to do so carryout a heat disinfection on the unit at the next convenient time.

 "Service Due"	<p>The unit has detected that the quality of the water being produced by the unit has exceeded the Set Quality Alarm</p>	<ol style="list-style-type: none"> 1. Using the touch screen check the water conductivity reading. 2. Check that the feedwater complies with the requirements as detailed in Section 12.1.7 of the service and maintenance manual 3. Check the incoming water quality using a calibrated handheld conductivity meter. 4. Check the product water quality with a calibrated handheld meter and compare to the value displayed on the screen. 5. Check that no water is leaking on the outside of the Permeate Line Cell E18. 6. Check the "Quality Setpoint" value in the alarm menu is set to the appropriate value. 7. Check that check valve P8 functions properly 	<ol style="list-style-type: none"> 1. If the water quality does not recover contact AmeriWater for advice. 2. Feedwater should meet all specifications in the manual 3. If the feed water exceeds the allowable specifications the supply may need to be changed. 4. If the product water matches the value displayed on the screen, perform a cleaning of the membrane. If a cleaning has been completed and the issue persists, the membrane may require a replacement. 5. If there is a leak in the system, fix the leak then dry the permeate line cell before returning the unit to service. 6. If the set point is too low for the environmental conditions, increase the set point to a more appropriate value. 7. Replace P8 if the valve is stuck open.
 "Poor Water Quality"	<p>The unit has detected that the quality of the permeate water is above 200µS/cm</p>	<p>Refer to "Service Due" message previously detailed. Note: Should the permeate quality reach a value of 200 µS/cm for a period of more than 20 seconds, the flow will be interrupted and returned to the integral tank.</p>	<p>If the water quality does not recover contact AmeriWater for advice.</p>

	“Poor Permeate Quality”	<p>The unit has failed to recover the water quality back to acceptable limits and has as a matter of safety shut down.</p>	<p>Refer to “Poor Water quality”. If after 10 minutes the quality does not improve and remains above 100 $\mu\text{S}/\text{cm}$ the unit will shut down and display the ‘Quality Alarm’. Should the quality fall below 100 $\mu\text{S}/\text{cm}$, within 10 minutes the unit will return to normal operation.</p>	<p>If the water quality does not recover contact AmeriWater for advice.</p>	
		“Over Temperature”	<p>During heat disinfection the unit has detected a temperature of the circulating water that is above the maximum limit and has aborted the cycle for safety.</p>	<ol style="list-style-type: none"> 1. Check that Temperature cut out switch E4 functions properly 2. Check to make sure that the fans on the system are not obstructed and function properly 3. Check that the temperature cut out sensor is connected to U23 on the control board 4. Check that the thermistor E11 is inserted into the path of flow. 	<ol style="list-style-type: none"> 1. Test the sensor for continuity. If the sensor fails open the “Over Temp” alarm will activate. 2. Contact Ameriwater for a replacement temperature cut out switch.
	“Thermal Trip”	<p>Temperature cut out switch, E4, has opened</p>	<ol style="list-style-type: none"> 1. Check that temperature switch, E4, has not become unplugged. 2. Check that the thermal switch has resistance (not open) 3. Check that wiring from switch to control board is not broken or damaged (Per electrical schematic) 	<ol style="list-style-type: none"> 1. Use manual reset button to close switch. 2. Run another Heatsan to make sure the switch does not trip again. 3. If switch trips during Heatsan, E29, Heater cutoff switch is faulty causing the heater to remain on allowing the tank to become over temperature. 4. Cycle power on the unit to clear the existing alarm. 	

 “Communications Error”	<p>A communication issue between the control and display board has been detected.</p>	<ol style="list-style-type: none"> 1. Check to make sure the RJ45 cable between the control and display board is connected and in good condition 	<ol style="list-style-type: none"> 1. Press the “START” button on the “Power On” screen. If the alarm is cleared, verify the software version on the RO and contact AmeriWater for the latest software version. 2. If the RJ45 cable appears damaged, contact AmeriWater for a replacement.
 “Real Time Clock Error”	<p>The PCB battery has died.</p>	<ol style="list-style-type: none"> 1. Check that a 2032 battery is installed in the proper slot on the PCB as detailed in section 9.3.12. 	<ol style="list-style-type: none"> 1. Replace the battery following section 9.3.12 in the manual 2. Once the battery is replaced, reset the date first followed by the time in the Time and Date menu.



indicates that a buzzer will sound.

10.1.2 Electrical & mechanical faults

Observed Fault	Reason/s	Checks	Proposed Actions
<p>The unit will not switch on and the screen is blank.</p>	<ol style="list-style-type: none"> 1. The mains incoming power supply has been disconnected. 2. The circuit breaker or other isolation device in your house has tripped out. 3. The power cord on the unit has become disconnected from either the unit or the wall socket. 4. The unit has developed a fault that requires assistance from your Healthcare provider. 5. Either the Internal or External fuses have "blown" 6. The display has become faulty or inoperable 	<ol style="list-style-type: none"> 1. Check that your area is not experiencing power cuts. 2. Check to see if the circuit breaker or other isolating device in your house has tripped and check other household appliances being used as they may be responsible for interrupting the power supply. 3. Check that the power cord is secure at both ends and check that it has not been damaged or cut. 	<ol style="list-style-type: none"> 1. If checks 1 – 3 have not proved to be the cause then contact AmeriWater for advice. DO NOT attempt to fix the fault or remove the side covers. 2. Check Internal and External fuses and replace if required.
<p>There is insufficient flow to run the dialysis machine.</p>	<ol style="list-style-type: none"> 1. A fault has occurred with the unit that has either stopped the unit or intermittently interrupts the production of purified water. 2. The incoming mains water supply has been cut off or has reduced pressure. 3. If fitted an external pre-treatment filter may have become blocked. 4. The reverse osmosis membrane may have become blocked or fouled. 5. The incoming feedwater supply temperature has dropped significantly. 6. One of the internal pressure sustaining valves may be incorrectly set or at fault. 	<ol style="list-style-type: none"> 1. Check for any displayed warning or alarm messages. Make a note of any displayed and refer to Section 9.2.1 for details. 2. Check your tap water to see if it is still running at a rate that seems to be normal and at an expected pressure. 3. If any pre-treatment filters or devices are fitted check to see if there are any leaks or faults. By disconnecting the feed water to the unit, there should be a flow after the pre-treatment equipment. 4. Check when the last time the unit was chemically cleaned and make a note of the date. 5. Only during extreme winter months would reduce water temperature be an issue. 	<ol style="list-style-type: none"> 1. If the unit is not showing any displayed messages but the problem persists carryout the checks 2-5. If any of the checks reveal a fault or you are not sure of what you have seen or feel the unit should be cleaned then contact AmeriWater with all the details and they will assist you. 2. If the fault is not related to items 1-5 then it may be due to the internal pressure sustaining valves, contact your Healthcare provider for assistance

The unit will not run when pressing the “START” button	1. The key switch at the rear of the unit is in the “CLEAN” position or there is a fault with the key switch itself.	1. Check the position of the key at the rear of the unit.	1. Turn the key to the “SERVICE” position. If the key is in the correct position and the unit still does not run, contact your Healthcare provider.
The unit repeatedly cycles power On and Off	1. There is a short at one of the components or on the printed circuit board	1. Check all connections to circuit board to find faulty component	<p>1. Begin by disconnecting power from the Centurion.</p> <p>2. Remove all plug ins to the circuit board. When all connections have been removed, turn the mains switch on the RO on.</p> <p>3. Begin by plugging in the 24V power supply into CON1.</p> <p>4. Continue plugging in connectors in a counter-clockwise direction until the unit begins flickering on and off.</p> <p>5. Once the issue reappears, replace the faulty component or repair the broken wire.</p>
Hot water fails to recirculate in the distribution loop	1. There is air trapped in the system due to a leak or component replacement	1. Remove the permeate line before PRV (P17) and allow the unit to burp any air bubbles out.	<p>1. If allowing the unit to burp does not solve the issue, remove and test P18 and P17 to verify cracking pressure.</p> <p>2. If valves continue to fail, contact AmeriWater for replacement.</p> <p>3. Perform a heat disinfection once valves are reinstalled to verify flow in loop.</p>

10.1.3 Water quality non-compliance

Non-compliance	Possible causes	Checks	Proposed actions
<p>Bacterial count and/or Endotoxin levels in dialysis water exceed recommended guidelines</p>	<ol style="list-style-type: none"> 1. Period between chemical disinfection/clean too long. 3. Increase in bacterial levels in feedwater. 4. Unit left for long periods idle. 5. RO membrane damaged. 6. Contaminated sample or poor sampling technique. 	<ol style="list-style-type: none"> 1. Refer to Section 10.1 for recommendations regarding frequency of chemical disinfection/clean. 3. Obtain samples of feedwater for analysis and/or contact local water supplier for updates on water quality. 4. Refer to Section 9.4 "Storage and preservation" for guidance when not using the unit. 5. Refer to section 9.6 "Pre-dialysis checks" to assess RO membrane performance. 6. Repeat analysis to confirm result. 	<ol style="list-style-type: none"> 1. It will be the responsibility of your healthcare provider to carry out these checks and diagnose the problem/s and rectify any faults founds. DO NOT use the unit if the water quality is unacceptable until you are told to do so by your Healthcare provider.
<p>Dialysis water quality: One or more of the Chemical contaminants exceed their permitted maximum concentration</p>	<ol style="list-style-type: none"> 1. Excessive increase in concentration of contaminant/s in feedwater. 2. RO membrane damaged 3. Contaminated sample or poor sampling technique. 4. Malfunction of pre-treatment system 5. Recommended Chemical clean frequency not being followed or change in chemical cleaner required. 	<ol style="list-style-type: none"> 1. Obtain sample of feedwater to assess level of contaminants. Contact local water authority if outside standards for drinking water. 2. Refer to section 9.6 Pre-dialysis checks to assess performance of RO membrane. 3. Repeat samples to confirm levels. 4. Check pre-treatment is functioning correctly. 5. Refer to Section 8.1.1 for detail of chemical clean frequency. 	<ol style="list-style-type: none"> 1. It will be the responsibility of your healthcare provider to carry out these checks and diagnose the problem/s and rectify any faults founds. DO NOT use the unit if the water quality is unacceptable until you are told to do so by your Healthcare provider.

10.2 Safety features and alarms

10.2.1 Tank low level

If at any time the water in the integral tank falls to the low level the process is interrupted, the RO boost pump stops and the inlet solenoid valve remains open. A **Tank Low Level** alarm message is displayed on the screen which alternates with the process message and selected function message.

Once the water level is restored to the mid-level sensor, the unit will automatically restart and the alarm message will clear.

10.2.2 Service due

This alarm will only be active in “**Processing**” when the Permeate Solenoid is energised/on.

Should the permeate water quality go above the ‘Set Quality Alarm’ value, refer to Factory Default settings **Section 7.5**, for a continuous period of 10 seconds, a *Quality Alarm* shall be generated.

The *Quality Alarm* will invoke a “**Service Due**” message on the **STATUS BAR**.

The *Quality Alarm* condition will sound the audible alarm (if enabled, refer to **Section 7.2.3**). Touching any part of screen will mute the audible alarm.

Once muted the audible alarm will re-activate after 3minutes if the *Quality Alarm* is still present.

Once invoked the permeate water quality value must drop to 5uS below the ‘Set Quality Alarm’ to reset/clear the *Quality Alarm* condition (providing a 5uS hysteresis).

The *Quality Alarm* feature can be disabled by setting the ‘Set Quality Alarm’ menu option to ‘0’ (Disabled), refer to **Section 7.2.3**.

10.2.3 Poor Permeate Quality

If at any time during **Processing** when the Permeate Solenoid is energised, the permeate water quality value rises above 200µS/cm for a continuous period of 20 seconds **“Poor Quality” Alarm** message will be displayed.

The **“Poor Quality”** alarm will cause the Permeate Solenoid to de-energise/close.

The **“Poor Quality”** alarm condition will sound the audible alarm (if enabled, refer to **Section 7.2.3**). Touching any part of screen will mute the audible alarm.

Once muted the audible alarm will re-activate after 3minutes if the **“Poor Quality”** alarm is still present.

The Permeate Solenoid will remain closed until the quality value goes below 100µS/cm. When the Permeate Solenoid energises/opens, the **“Poor Quality”** message will clear from the display.

If the permeate water conductivity value remains above 100µS/cm for 10 minutes, an ‘Active’ **Quality Alarm** will be generated.

An “Active”, **Poor Quality Alarm** will invoke the **Power On** state, with any outputs on going off and stop the unit. A message “Quality Alarm” will be displayed on the STATUS BAR.

Pressing the **“START”** button will reset the **Poor Quality Alarm** condition, allowing the unit to run in a **Processing** condition.

The feature can be able to be disabled by setting the “Set Quality Alarm” menu option to ‘0’ (“Disabled”)

10.2.4 High pump pressure

If at any time during normal service the system pressure exceeds 15 bar (218 psi) for more than three seconds, a **High Pressure** alarm message will be displayed and the alarm sounded if the audible alarm has been enabled. See **section 10.0, Troubleshooting**, for possible causes.

If the pressure continues to rise and exceeds 15.5 bar (225 psi) the unit will shut down and the display will revert to the **Power-On** mode and continue to show the alarm message **High Pressure**.

If at any time during cleaning, the system pressure exceeds 15 bar (218 psi) (3.5 bar while equalize solenoid is active during heat disinfection) for more than three seconds the cleaning cycle will stop, a **High Pump Pressure** alarm message will be displayed and sounded. Press anywhere on the screen to mute the buzzer. Once the high-pressure condition has been cleared select the **Restart** option to resume the clean cycle from the point at which it was interrupted.

10.2.5 Low pump pressure

Should the system pressure fall below 1 bar (15 psi) for a few seconds during normal processing, the unit will shut down and the display will revert to the **Power-On** screen, showing the message **Low Pressure**. Pressing the start button will restart the unit and the alarm will clear if the pump pressure has returned to normal.

10.2.6 Permeate line cell error

If the permeate line cell senses an open circuit condition the permeate flow is interrupted and the display produces the message, **Out-Line Cell Error**. This is usually the result of a faulty or disconnected line cell. Once corrected the flow resumes.

10.2.7 Temperature high

If the water temperature of the permeate is higher than the set temperature, the display produces a **Temperature High** alarm message. The default temperature setting is 95°F and can be accessed and changed via the settings menu; refer to **Section 7.2.3**.

10.2.8 Temperature sensor error

If the measured temperature is out of range, the displayed value will be “===”. Also a ‘Temperature Sensor Error’ message will be displayed.

10.2.9 Level switch error

A **Level Sensor Error** message is displayed if the input to the control board from the three level sensors in the break tank is not one of the possible water level states.

10.2.10 Leak

If water is sensed in the bottom of the unit the unit will revert to the power on screen, and a leak detection alarm message will be shown.

10.2.11 Tilt

If the unit, while turned on, is tipped from the vertical by more than 15° for 0.5 seconds or more the unit will stop, the display will revert to the **Power-On** screen and sound its alarm. Switch the unit off and on at the mains plug to restart.

10.3 Processing modes

10.3.1 External Standby

When in external standby state the unit shuts down and the message **STBY;EXT** (external standby condition) is displayed. This occurs in response to a signal from an external switch, timer, dialysis machine or the remote key switch connected via the jack plug at the rear of the unit;

10.3.2 Power On /Timed standby

For either function to operate and for the status bar to be displayed, both **Power On Standby** and **Timed Standby** have to be enabled in the menu structure.

Power on standby

When this mode is enabled the unit performs a 10 minute rinse cycle every 2 hours after the stop button has been pressed. The purpose is to ensure the system remains clean and ready for use when next required.

Timed standby

When this mode is enabled the unit may be programmed to allow the rinse cycle of 'Power on standby' between predetermined 'Stop' and 'Start' times. This is of benefit to patients during sleeping hours.

Pressing the start button at any time will override these functions and place the unit back into normal operation supplying water for dialysis.

If an external signal is used for control of the unit (external standby) this overrides the programmed standby times.

Standby messages displayed on the status bar:

In POWER-ON (with Timed Standby enabled):

“ Timed Standby Enabled” is toggled with “POWER-ON”.

During the 10 minute run period;

“ Timed Standby Enabled” is toggled with “STANDBY RUN”.

In processing (with Timed standby enabled and a signal present on the external input);

“ Timed Standby Enabled” is toggled with “STBY:EXT”

During the 10 minute run period;

“ Timed Standby Enabled” is toggled with “STANDBY RUN”.

The “ Timed Standby Enabled” message is a warning that the unit will periodically start and run automatically.

11 CONSUMABLES AND SPARES

11.1 Consumables

Consumable Part no.	Description
20-0047	Ultra-filter**
37-0006	AMERICLEAN A POWDER-CENTURION*
37-0007	AMERICLEAN B POWDER-CENTURION*

Notes:

* Refer to, “**Chemical cleaning and heat disinfection instructions**”, **Section** Error! Reference source not found. for details.

Refer to **Section 9.5.1 for details on how to replace the Ultra-filter and **Section 9.5.2** for recommended replacement frequency.

11.2 Recommended spares list

11.2.1 Minor spares listing

The minor spares listing has been classified as those spare parts that can be removed and replaced in less than 1 hour, that require minimal retesting, are low risk and can be carried out by a trained/authorised technician without reference to **AmeriWater**.

*Instructions on how to replace/refit these items can be found in **Section 9.3** “Unplanned minor maintenance and repairs”.

Minor Spares Listing for Centurions.

Part No.	Part Description
59-0062	Chemical draw valve (S3)
59-0061	Inlet valve (S1)
59-0061	Drain#1 valve (S4)
59-0062	Permeate valve (S2)
80-0280	RO boost pump (E8)
80-0281	RO Boost Pump Speed Controller (E7)
41-0052	Turbine flow assembly (E16)
59-0061	Equalize valve (S6)
59-0061	Blend valve (S7)
59-0061	Drain#2 valve (S5)
RR082006	20mm, 5A fuse, electrical box
RR083349	Lithium battery, main PCB
66-0181	Lead, mains, C19/US
63-0045	15A, fuse, external
08-0025	8mm, clear, tubing
08-0030	Tubing, 8mm, Green
08-0031	Tubing, 8mm, Red
08-0032	Tubing, 8mm, Blue
08-0033	Tubing, ½”, Green

08-0022	Tubing, 4mm, Nylon Nat
0012-0001	Distribution Loop c/w bio sample point
16-0106	Walther .38 BSPP Stainless Steel Q-Con
16-0107	Q-Con, Hose Barb, Walther, PVDF
044-0126	Valve, Sanitary Sampling Port, SST
10-L380	LEGRIS Male Con, 8 mm T x .125 BSPT
10-0059	LEGRIS Stainless Steel Tubing Support
90-0133	Manifold, Adapter, Centurion PVDF
0121-0052	Ultra-filter bypass, Centurion
90-0174	Bracket, Retaining, Centurion
08-0050	Tubing, Insulation, 3/8", Black
08-0051	Tubing, Insulation, 3/4", Black

11.2.2 Major spares listing

Major spares are classified as those spares/assemblies that could require significant downtime to complete and may require assistance from **AmeriWater** due to their sensitivity. If you need to replace one of the items/assemblies listed in the table below, contact **AmeriWater** for specific instructions.

Major Spares Listing for Centurions

Part No.	Part Description
67-0018	Level switch assembly
RR083353	Centurion, TFT LCD Touch Screen (MD)
RR082027	Centurion, PCB, Touch Screen Driver
RR083413	Main PCB
77-0023	SMPS C11 24V
38-0006	Heater lead assembly
R0124-0001	Heat Sanitizable membrane

11.3 Centurion by AmeriWater Exploded Diagrams

11.3.1 Break Tank Detail

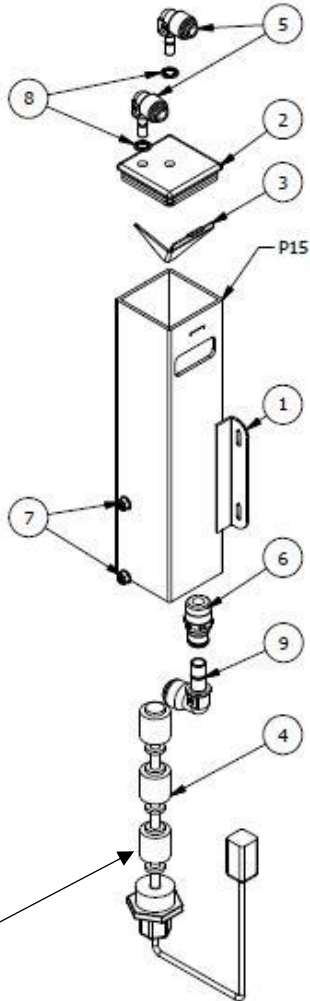

ITEM	QTY	PART NUMBER	DESCRIPTION
1	1	90-0139	CENTURION, BREAK TANK ASSEMBLY
2	1	999-3643	CAP,BREAK TANK,CENTURION SERIAL#17XXXX
3	1	NA	BAFFLE,CENTURION BREAK TANK
4	1	67-0018	SWITCH, LEVEL, 3 POSITION, 4 COND CABLE, 4 PIN DEUTSCH CONNECTOR, CENTURION
5	10	010-0001	PLUG-IN ELBOW, 5/16" STEM X 5/16" T,KYNAR,TRUE-SEAL
6	2	010-0002	LEGRIS MALE CON, 0.5T X 0.5MPT,SS
7	23	92-0112	NUT,8-32,NYLOCK,SS
8	2	999-3642	RETAINING RING,EXTERNAL PUSH,SS,5/16"
40	1	010-0103	TRUESEAL TUBE ELBOW UNION, 1/2T X 1/2 STEM

*Item #3 will be included with Item #1 when purchased

11.3.2 Heater Tank Detail

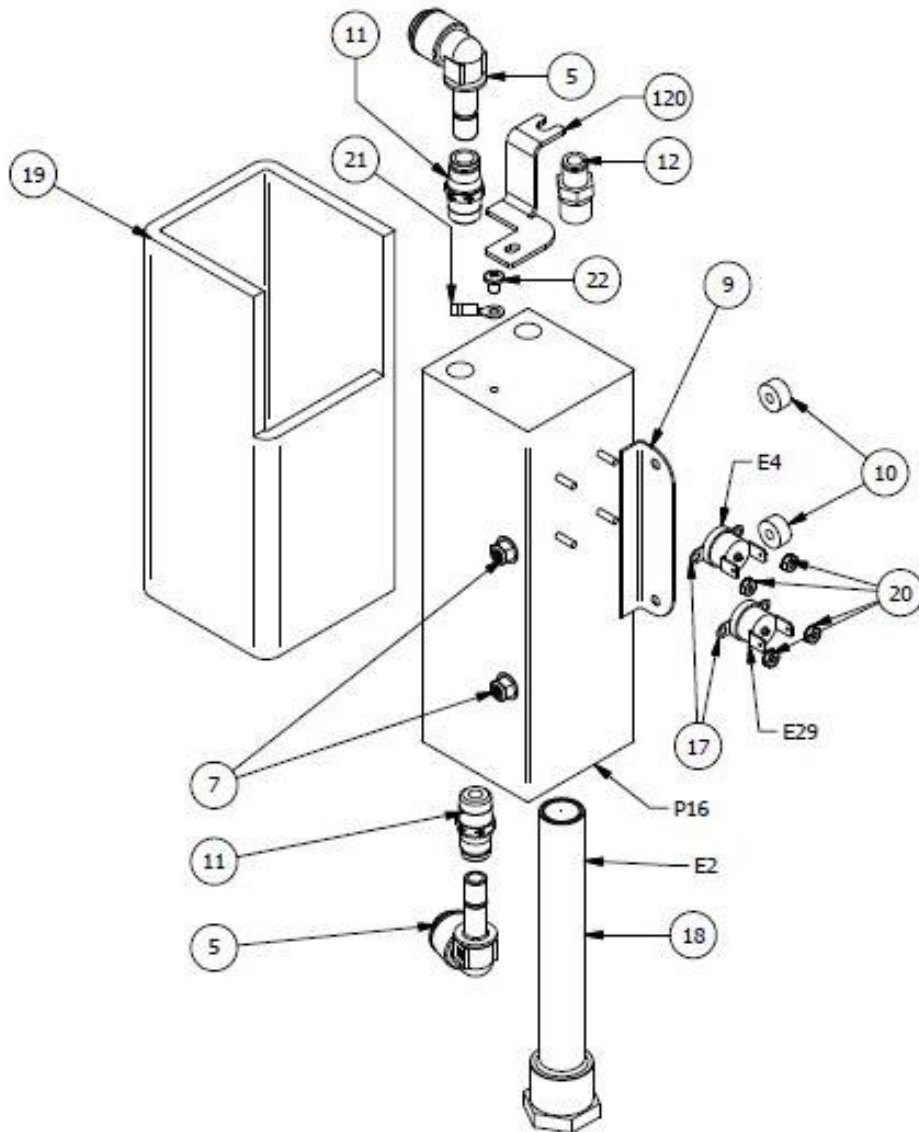

ITEM	QTY	PART NUMBER	DESCRIPTION
5	2	010-0001	PLUG-IN ELBOW, 5/16" STEM X 5/16" T,KYNAR,TRUE-SEAL
9	1	090-0005	CENTURION HEATER TANK
10	2	999-3644	SPACER,CENTURION HEATER TANK,1/4",NYLON
11	2	010-0005	LEGRIS MALE CON, 8MM T X 0.25 NPT,SS
12	1	010-0120	LEGRIS MALE CON, 0.25T X 0.25MPT
17	2	065-0001	SWITCH,THERMAL TRIP,CENTURION (E29,E4),95 deg C
18	1	38-0006	HEATER,1.5 kW,120 V,CENTURION
19	1	NA	INSULATION, HEATER TANK
20	4	092-0009	NUT,LOCKING,#4-40,STAR WASHER,18-8 SS
21	14	66-0145	TERMINAL, RING LUG, #8 STUD SIZE, 22-16AWG, VINYL INSULATED, RED
22	1	92-0099	SCREW, 8-32 X 1/4", PAN, PHILLIPS, SS
120	1	90-0174	BRACKET,RETAINING,CENTURION,316SS

11.3.3 Pump Side Plumbing Detail

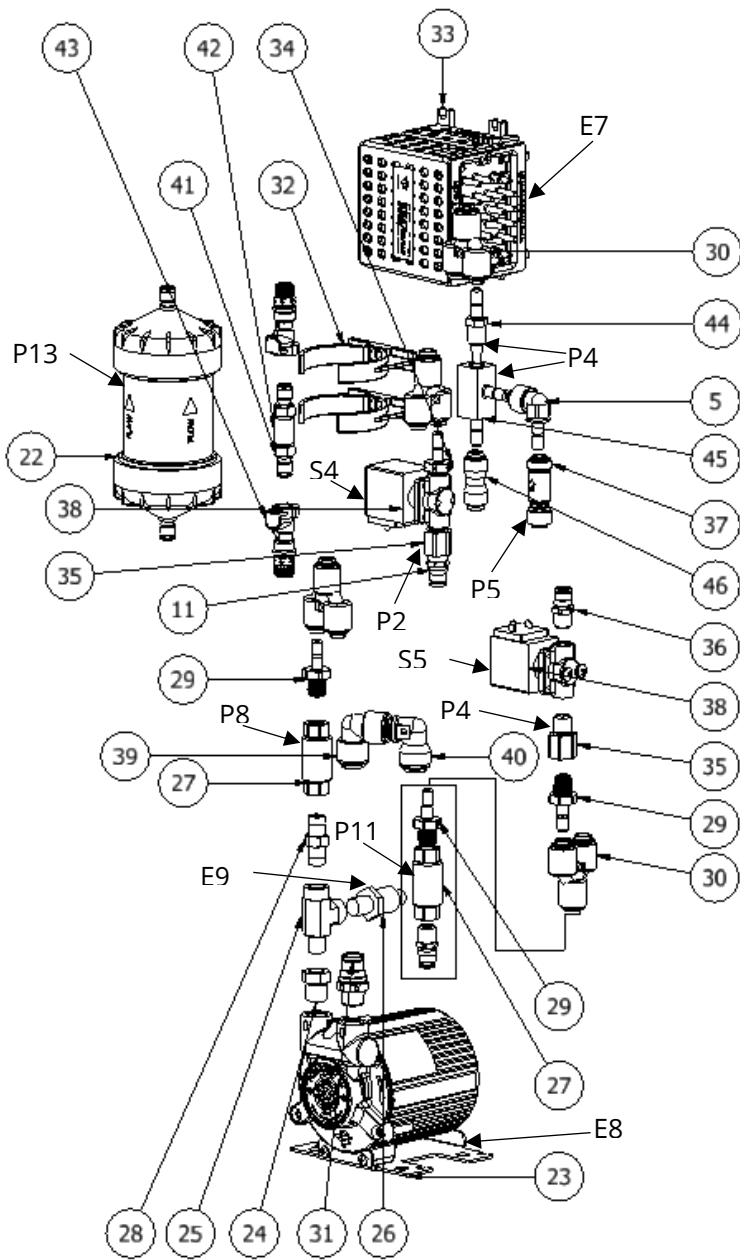

ITEM	QTY	PART NUMBER	DESCRIPTION
5	10	010-0001	PLUG-IN ELBOW, 5/16" STEM X 5/16" T,KYNAR,TRUE-SEAL
11	6	010-0005	LEGRIS MALE CON, 8MM T X 0.25 NPT
22	1	20-0047	ULTRA-FILTER CAPSULE
23	1	80-0280	PUMP,FLUID-O-TECH,TMFR SERIES, ROTARY VAIN,STAINLESS STEEL,CENTURION
24	1	144-0003	BUSH,.375" x .25" THD,SS,PARKER
25	1	144-0002	TEE,MALE RUN,.25" MNPT x .25" FNPT x .25" FNPT,SS,PARKER
26	1	999-3641	TRANSDUCER,0-5V,0-16 BAR,1/4" NPT MALE,M12 4 PIN CONNECTOR,SS
27	2	55-0028	VAL,CHECK,1/4" FNPT,316L,REPLACEMENT CENTURION P8/P9/P11
28	1	144-0001	NIPPLE,.25xCL,SS,PARKER
29	6	047-0012	MALE STUD, 1/4" NPT X 5/16" STEM,SS
30	7	010-0009	SPLITTER,Y DIVIDER,5/16" x 5/16",KYNAR,TRUE-SEAL
31	1	010-0008	LEGRIS MALE CON,.5" T x .375" NPT,SS
32	2	91-0015	CLIP,2.5",MEMBRANE HOUSING, ULTRA-FILTER,WHITE
33	1	80-0281	INVERTER,FLUID-O-TECH,120V,60 Hz,CENTURION
34	1	047-0011	MALE STUD, 1/4" BSPT X 5/16" STEM,SS
35	2	042-0003	FLOW RESTRICTOR,1/4" FBPST X 1/4" MNPT,0.8MM ORIFICE,SS
36	3	010-0010	LEGRIS,MALE CON,8MM T x 1/4" BSPT,SS
37	2	55-0027	VAL,CHECK,5/16" TUBE, ACETAL RESIN, REPLACEMENT CENTURION P5/P6
38	5	59-0061	VAL, SOL, 1/4" BSPT, NC, 24V DC, 316L, REPLACEMENT S1/S4/S5/S6/S7
39	1	147-0001	UNION ELBOW,1/2" T,KYNAR,TRUE-SEAL
40	1	147-0002	UNION ELBOW,1/2" STEM X 1/2" T,KYNAR,TRUE-SEAL
41	2	16-0102	Q-CON,CPC MALE COUPLING INSERT,.25 NPT,NON-VALVED
42	1	044530301	COUPLG,.25,THRD,SST304
43	2	16-0101	Q-CON,CPC FEMALE COUPLING BODY WITH SHROUD,8mm PTF IN-LINE
44	1	010-0012	VENTURI NOZZLE,1/4" MNPT X 8MM T, .031" NOZZLE,SS,CENTURION SERIAL #17XXXX
45	1	010-0011	VENTURI BODY,1/4" FNPT X 8MM T,SS,CENTURION SERIAL #17XXXX
46	1	010-0013	UNION,5/16" T X 5/16" T,KYNAR,TRUE-SEAL

Items 44 & 45 will be ordered together

11.3.4 Membrane Assembly Detail

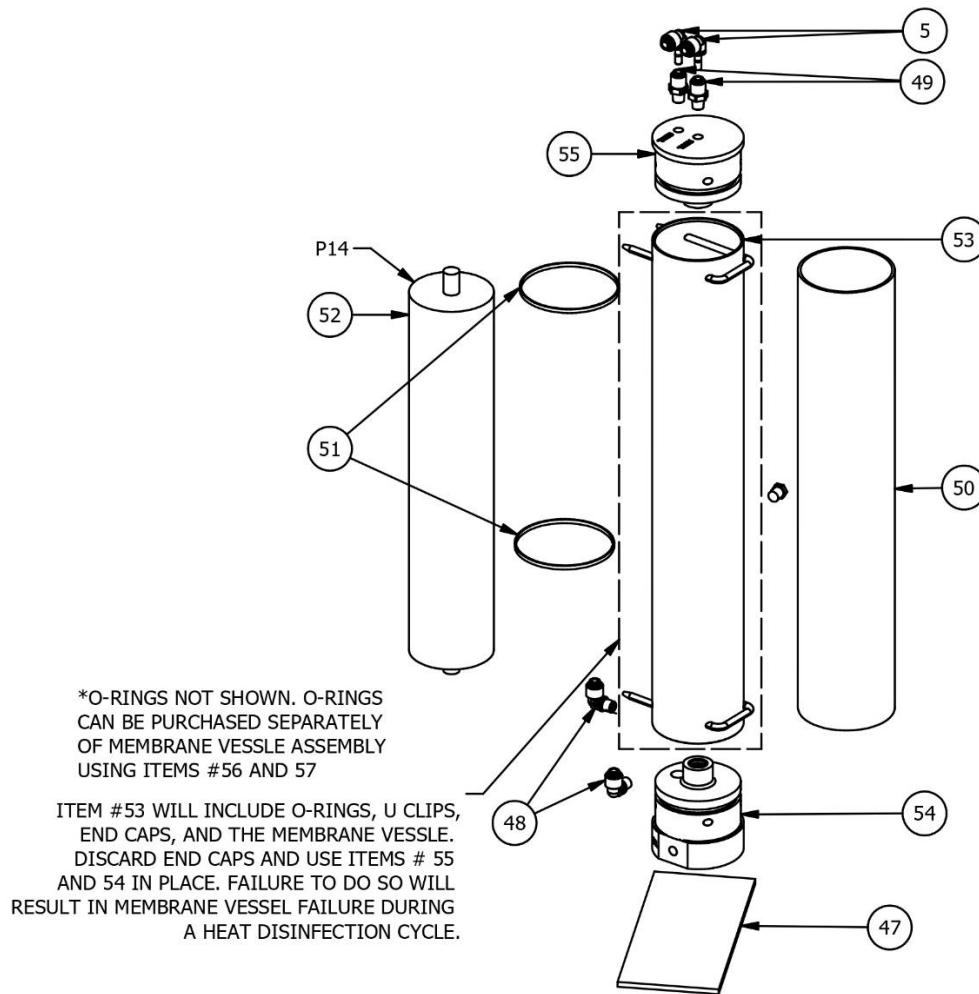

ITEM	QTY	PART NUMBER	DESCRIPTION
5	5	010-0001	PLUG-IN ELBOW, 5/16" STEM X 5/16" T,KYNAR,TRUE-SEAL
47	1	NA	VIBRATION ISOLATION PAD FOR PUMP AND MEMBRANE
48	2	010-0014	MALE ELBOW,5/16" T x 1/4" MNPT,KYNAR,TRUE-SEAL
49	2	010-0015	MALE CON.5/16" T x 1/4" MNPT,TRUE-SEAL
50	1	NA	INSULATION, MEMBRANE VESSEL
51	2	999-3648	CABLE TIE,17" LONG,BLACK
52	1	R0124-0001	Centurion,Serial # Format USA Version17XXXX,Membrane Assy(P14)
53	1	024-0004	HOUSING,MEMBRANE,SS,4"x21",CENTURION SERIAL #17XXXX
54	1	999-3649	END CAP,MEMBRANE,LOWER,CPVC,CENTURION SERIAL #17XXXX
55	1	999-3650	END CAP,MEMBRANE,UPPER,CPVC,CENTURION SERIAL #17XXXX
56	4	999-3646	O-RING,INTERNAL FOR MEMBRANE END CAP,CENTURION SERIAL #17XXXX
57	2	999-3647	O-RING,EXTERNAL FOR MEMBRANE END CAP,CENTURION SERIAL #17XXXX

11.3.6 Right Hand Side Detail

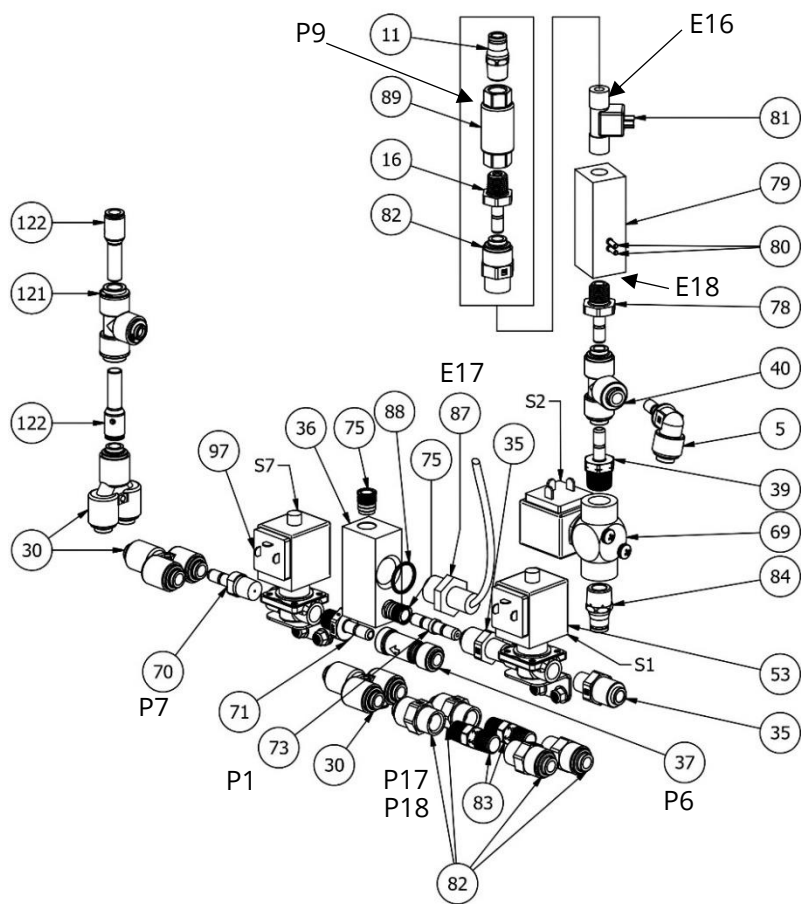

ITEM	QTY	PART NUMBER	DESCRIPTION
5	10	010-0001	PLUG-IN ELBOW, 5/16" STEM X 5/16" T, KYNAR
11	3	010-0005	LEGRIS MALE CON, 8MM T X 0.25 NPT, SS
12	2	999-3645	CENTURION THERMISTOR FITTING
29	6	047-0012	MALE STUD, 1/4" NPT X 5/16" STEM, SS
30	7	010-0009	SPLITTER, Y DIVIDER, 5/16" x 5/16", KYNAR, TRUE-SEAL
36	3	010-0010	LEGRIS, MALE CON, 8MM T x 1/4" BSPT, SS
37	1	55-0027	VAL, CHECK, 5/16" TUBE, ACETAL RESIN, REPLACEMENT CENTURION P5/P6
69	2	59-0062	VAL, SOL, 3/8" BSPT, NC, 24V, 316L, REPLACEMENT CENTURION S2/S3
70	1	042-0004	FLOW RESTRICTOR, 1/4" BSPT x 5/16" STEM, 1 L/MIN, CPVC
71	1	010-0027	TUBE STEM ADAPTER, 5/16" STEM x 1/4" BSPT, KYNAR, TRUE-SEAL
72	2	010-0026	MALE CON, 5/16" T x 1/4" BSPT, KYNAR, TRUE-SEAL
73	1	042-0005	FLOW RESTRICTOR, 8MM STEM x 8MM STEM, 2 MM, 1 GPM, CPVC
74	1	010-0029	MANIFOLD, BLOCK, FEED LINE CELL, For CENTURION, 8MM T
75*	2	NA	LIQUIDFIT CARSTICK CARTRIDGE, 5/16" T
76	1	014-0001	MALE STUD, 3/8" BSPT X 5/16" STEM, SS
77	1	010-0024	TEE UNION, 5/16" T, KYNAR, TRUE-SEAL
78	1	010-0023	TUBE STEM ADAPTER, 5/16" STEM x 1/4" MNPT, KYNAR, TRUE-SEAL
79	1	010-0022	MANIFOLD, PERMEATE LINE, CENTURION SERIAL #17XXXX
80**	2	NA	LINE CELL PIN, PURE WATER MANIFOLD
81	1	41-0052	FLOWMETER, TURBINE, LOW FLOW, .026-.65 GPM, CENTURION
82	5	010-0021	FEMALE CON, 5/16" T x 1/4" FNPT, KYNAR, TRUE-SEAL
83	1	055-0009	VALVE, CHECK, 25 PSI CRACKING, 20-65 PSI ADJUSTABLE, 1/4" MNPT, SS, GENERANT, CENTURION, P18
84	1	010-0025	LEGRIS, MALE CON, 3/8" BSPT x 8MM T, SS
87	1	NA	FEED LINE CELL (INDIVIDUAL PART NOT FOR SALE)
88	1	13-0009	O-RING, .739" ID, EPDM Centurion O-ring for conductivity cell
89	1	55-0028	VAL, CHECK, 1/4" FNPT, 316L, REPLACEMENT CENTURION P8/P9/P11
121	1	010-0185	TEE, UNION, 3/8T X 1/4T, KYNAR, TRUE-SEAL
122	2	010-0184	LEGRIS REDUCER, 3/8 STEM X 5/16T

*QTY 2 ITEM #75 WILL BE INCLUDED WITH ITEM #74

**QTY 2 ITEM #80 WILL BE INCLUDED WITH ITEM #79

11.3.7 Side Panel Detail

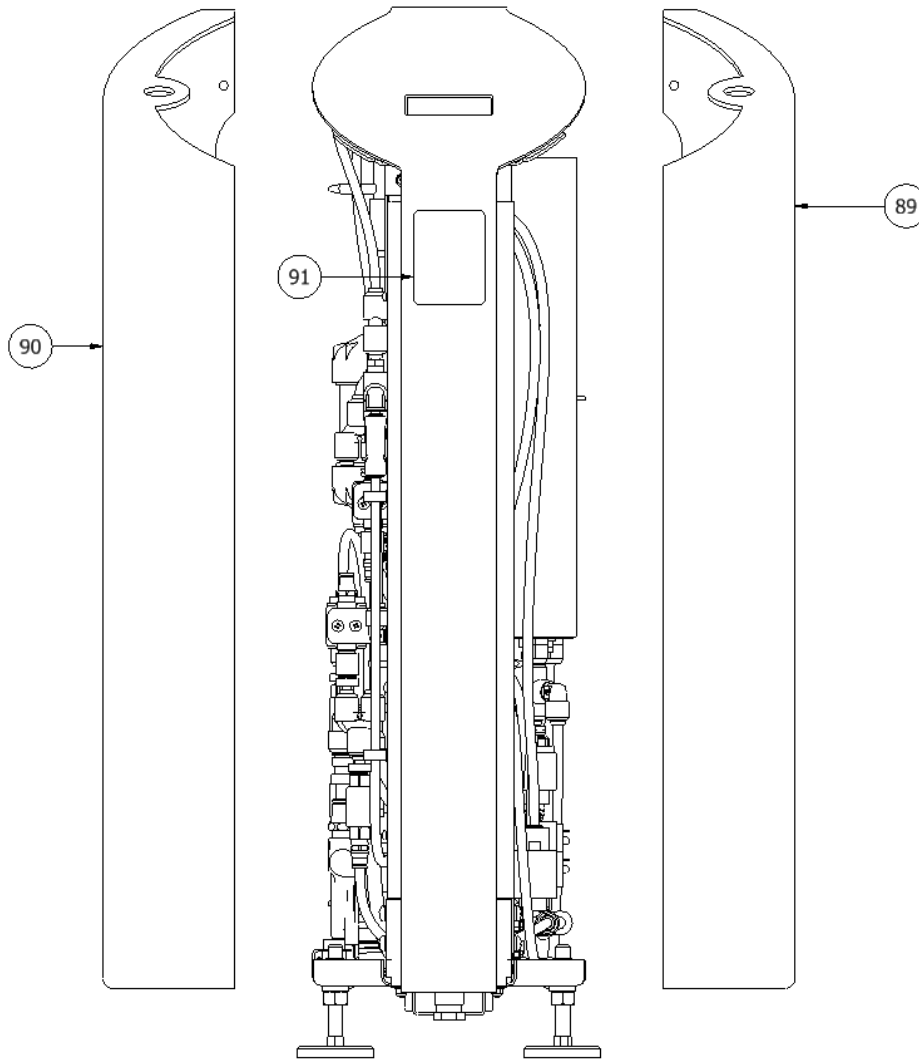

ITEM	QTY	PART NUMBER	DESCRIPTION
89	1	90-0137-RH	COVER, CENTURION BY AMERIWATER RIGHT HAND, UL COMPONENT LISTING NEEDED
90	1	90-0137-LH	COVER, CENTURION BY AMERIWATER LEFT HAND, UL COMPONENT LISTING NEEDED
91	1	99-9117	LABEL, CENTURION

11.3.8 Control Panel Detail

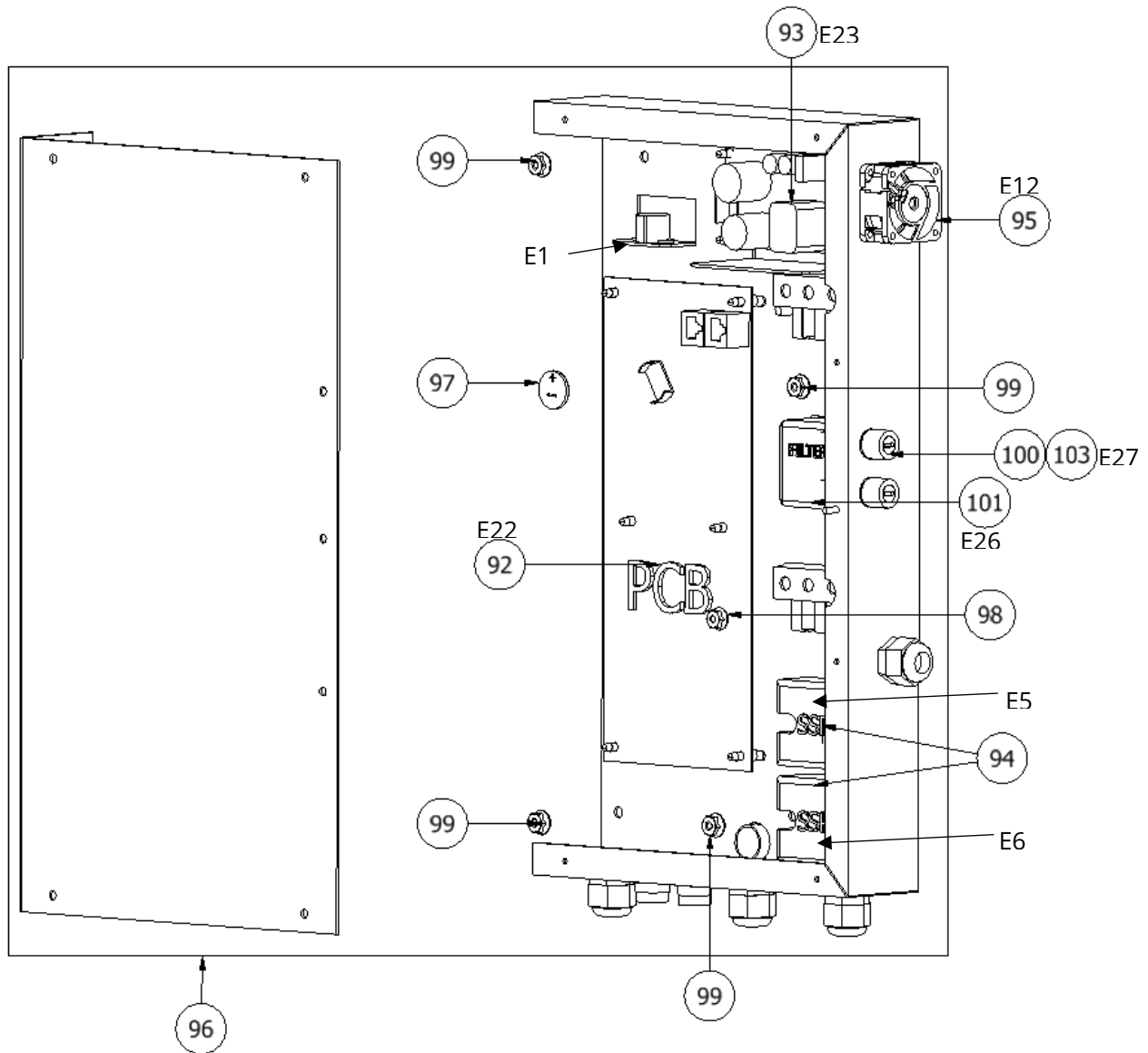

ITEM	QTY	PART NUMBER	DESCRIPTION
92	1	RR083413	CENTURION, PCB MAIN (MD)
93	1	77-0023	POWER SUPPLY, AC/DC,24V, HIGH EFFICIENCY, 160W,CENTURION
94	2	64-0053	RELAY,SOLID STATE,1 PHASE,25A,CENTURION
95	1	69-0119	FAN,12VDC,ELECTRICAL PANEL,CENTURION
96	1	0153-0195	CONTROL, ELECTRICAL BOX ASSEMBLY. CENTURION
97	1	RR083349	BATTERY 3V ION CR2032
98	14	92-0097	NUT, 8-32, FLANGED, SS
99	4	92-0098	NUT, 10-24, FLANGED, SS
103	2	RR082006	CENTURION,FUSE - MAIN 20mm 5A
100	2	NA	Fuse Holder, Electrical panel
101	1	NA	EMC Filter

11.3.9 Touch Screen Detail

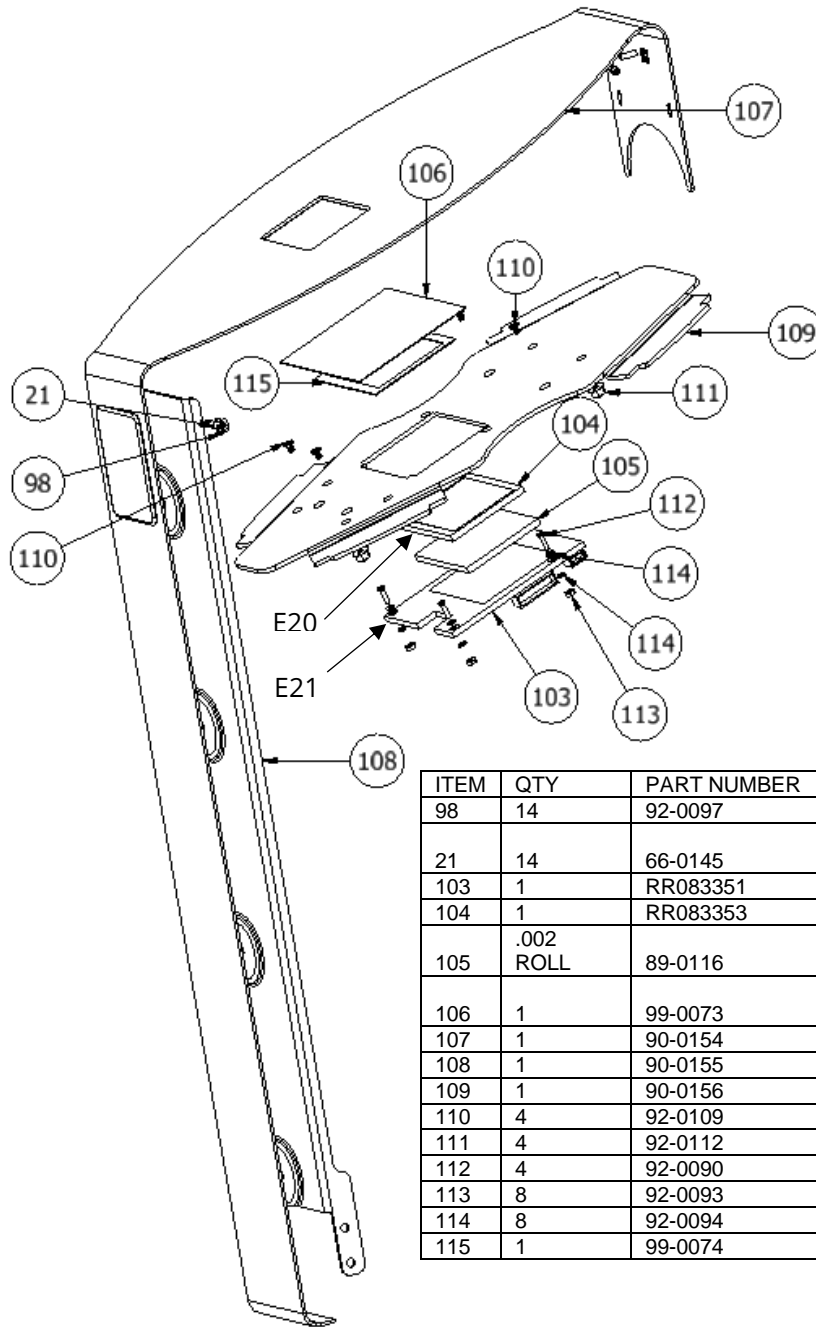

ITEM	QTY	PART NUMBER	DESCRIPTION
98	14	92-0097	NUT, 8-32, FLANGED, SS
21	14	66-0145	TERMINAL, RING LUG, #8 STUD SIZE, 22-16AWG, VINYL INSULATED, RED
103	1	RR083351	CENTURION TOUCH SCREEN DRIVER PCB
104	1	RR083353	CENTURION,TFT LCD TOUCH SCREEN (MD)
105	.002 ROLL	89-0116	TAPE, FOAM, DOUBLE SIDED, 3" WIDTH X 1/8" THICK, 36 YD ROLL
106	1	99-0073	PROTECTIVE LABEL, TOUCH SCREEN, CENTURION 1500
107	1	90-0154	TOP PLATE, CENTURION
108	1	90-0155	BRACE, FRONT PANEL, CENTURION
109	1	90-0156	DISPLAY MOUNT, CENTURION
110	4	92-0109	SCREW,8-32 X .25,FLAT,PHILLIPS,SS
111	4	92-0112	NUT,8-32,NYLOCK,SS
112	4	92-0090	SCREW, 4-40 X .5, FLAT HEAD, PHILLIPS, SS
113	8	92-0093	NUT, 4-40, HEX, SS
114	8	92-0094	Washer, #4, NYLON
115	1	99-0074	GASKET, TOUCH SCREEN, CENTURION 1500

11.3.10 S3 & S6 Detail

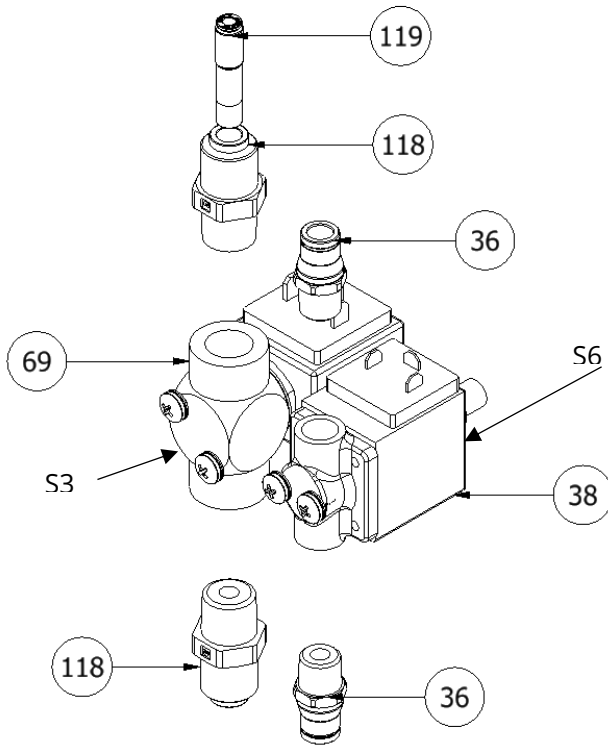

ITEM	QTY	PART NUMBER	DESCRIPTION
36	3	010-0010	LEGRIS,MALE CON,8MM T x 1/4" BSPT,SS
38	5	59-0061	VAL, SOL, 1/4" BSPT, NC, 24V DC, 316L, REPLACEMENT S1/S4/S5/S6/S7
69	2	59-0062	VAL, SOL, 3/8" BSPT, NC, 24V, 316L, REPLACEMENT CENTURION S2/S3
118	2	010-0028	MALE CON,5/16" T x 3/8" BSPT,KYNAR,TRUE-SEAL
119	1	010-0030	LEGRIS,REDUCER,8MM STEM x 4MM T

12 TECHNICAL SPECIFICATIONS

12.1 Technical specification

12.1.1 Electrical specifications/connections

Mains supply

Electrical supply	Operation	Max Power consumption (Watts)
Single phase 115V 60Hz plus earth	Standby	10
	Normal operation	160
	Heated disinfect operation	1660



Warning: To avoid risk of electric shock, this equipment must be connected to a supply main with protective earth.

For permanent installations the mains supply must be provided with a Branch Circuit Breaker, refer to **Section 5.5.2** for details of rating and specification of Branch Circuit Breaker.

12.1.2 Fuse rating/type

External: (Located at the rear of the unit)

Type: 2 -15 Amp **T15AH115V**- 5mm x 20mm, Ceramic, time delay:

Internal: (Located in main electrical tray)

Type: 2-5 Amp **T5AH115V** – 5mm x 20mm, Ceramic, time delay

Note: Fuses must only be replaced with those approved and supplied by **AmeriWater**.

12.1.3 Main PCB battery specification

Voltage: **3V**

Type: **Lithium, CR2032**

12.1.4 IP Rating

The unit has an **IP21** rating.

2 = Protected against solid objects greater than 0.492" (12.5mm)

1= Protected from vertically dripping water

12.1.5 Water quality and performance

Max drain flow-rate @ 10°C USgals/min	Permeate output @ 10°C USgals/min	Recovery %	Output water quality
0.29	0.4	60%	Will meet the requirements of current AAMI/ANSI/ISO:13959 standard for <i>“water for hemodialysis and related therapies”</i>

12.1.6 Feed water requirements

Pre-filtration	Filtered to 5 microns
Total Hardness	Maximum 400 ppm as CaCO ₃
Temperature	34 – 95°F (1-35°C)
Chlorine (Total)	<0.1 ppm free Cl ₂
Total dissolved solids (max)	1500 mg/l
Fouling index	<5
Feed water pressure	2-6 bar (30-90 psi)*
Feed water flowrate	1-1.5USgals/min (3.8-5.7ltrs/min)

* set to 3 bar on commissioning

12.1.7 Water services connections

Connection	Description	Size	Type
Drain	Unit waste water-out	8mm	Push fit
In	Feedwater supply-in	8mm	Push fit
Out	Permeate-out	8mm	Push fit
Return	Returned permeate-in	8mm	Push fit
Acid	Chemical disinfectant-in	4mm	Push fit

12.1.8 Raw water break tank

Working volume: 0.115 US gals (435 mls)
 Classification: 20mm air gap to provide backflow prevention
 Material: 316 Stainless steel

12.1.9 Weights and dimensions

Weight (Lbs)	Height (inches)	Width (inches)	Depth (inches)
86 (Dry) 99 (Working)	34	11	19

12.1.10 USB mass storage device

Specification: FAT 16 formatted USB memory stick
Memory size: Must be less than 2GB

12.2 Environmental data

Parameter	Normal Operation	Storage	Transport
Temperature range	50-104°F (10 to 40°C)	41 °F-158°F (5 to 70°C)	23°F -158°F (-5 to +70°C)
Relative humidity	30 to 75%	10-100%	10-100%
Atmospheric pressure range (altitude)	80 to 106 KPa (sea level-2000m or 0-6,562 ft)	50 to 106 KPa (sea level-5000m or 0-16,404 ft)	50 to 106 KPa (sea level-5000m or 0-16,404 ft)

12.3 Guidance on electromagnetic emissions

Guidance and manufacturer’s declaration – electromagnetic emissions		
The Centurion by AmeriWater is intended for use in the electromagnetic environment specified below. AmeriWater or Healthcare Provider should assure that it is used in such an environment.		
Emissions Test	Compliance	Electromagnetic environment - guidance
RF emissions CISPR 11	Group 1	The Centurion by AmeriWater uses RF energy only for its internal function. Therefore, its RF emissions are very low and are not likely to cause any interference in nearby electronic equipment. The Centurion by AmeriWater is suitable for use in all establishments, including domestic establishments and those directly connected to the public low-voltage power supply network that supplies building used for domestic purposes.
RF emissions CISPR 11	Class B	
Harmonic emissions IEC 61000-3-2	Class A	
Voltage fluctuations / Flicker emissions IEC 61000-3-3	Complies	

12.4 Guidance on electromagnetic immunity

Guidance and manufacturer's declaration – electromagnetic immunity			
The Centurion by AmeriWater is intended for use in the electromagnetic environment specified below. AmeriWater or your Healthcare Provider should assure that it is used in such an environment.			
Immunity test	IEC 60601 test level	Compliance Level	Electromagnetic environment - guidance
Electrostatic discharge (ESD)	± 6 kV contact	B	Floors should be wood, concrete, or ceramic tile. If floors are covered with synthetic material, the relative humidity should be at least 30%.
IEC 61000-4-2	± 8 kV air	A	
Electrical fast transient / burst	± 2 kV for power supply lines	A	Mains power quality should be that of a typical commercial or hospital environment.
IEC 61000-4-4	±1 kV for input / output lines	N/A	
Surge	± 1 kV line(s) to line(s)	A	Mains power quality should be that of a typical commercial or hospital environment.
	IEC 61000-4-5	± 2 kV line(s) to earth	
Voltage, dips, short interruptions and voltage variations on power supply input lines	<5% U_T (> 95% dip in U_T) for 0.5 cycle	B	Mains power quality should be that of a typical commercial or hospital environment. If the user of the unit requires continued operation during power mains interruptions, it is recommended that the Centurion be powered from an uninterruptable power supply.
	40% U_T (60% dip in U_T) For 5 cycles	B	
	70% U_T (30% dip in U_T) For 25 cycles	B	
	<5% U_T (>95% dip in U_T) For 5s	B	
Power frequency (50/60 HZ) magnetic field	3 A/m	A	Power frequency magnetic fields should be at levels characteristic of a typical location in a typical commercial or hospital environment.
IEC 61000-4-8			
NOTE U_T is the a.c. mains voltage prior to application of the test level.			

12.5 Guidance on electromagnetic immunity for non-life supporting equipment

Guidance and manufacturer's declaration – electromagnetic immunity			
The Centurion by AmeriWater is intended for use in the electromagnetic environment specified below. AmeriWater or your Healthcare Provider should assure that it is used in such an environment.			
Immunity test	IEC 60601 test level	Compliance Level	Electromagnetic environment - guidance
Conducted RF IEC 61000-4-6	3 Vrms 150 kHz to 80 MHz	3V	Portable and mobile RF communications equipment should be used no closer to any part of the Centurion, including cables, than the recommended separation distance calculated from the equation applicable to the frequency of the transmitter. Recommended separation distance $d = [1.17] \sqrt{P}$
Radiated RF IEC 61000-4-3	3 V/m 80 MHz to 2.5 GHz	3V/m	$d = [1.17] \sqrt{P}$ 80 MHz to 800 MHz $d = [2.33] \sqrt{P}$ 800 MHz to 2.3 GHz Where P is the maximum output power rating of the transmitter in watts (W) according to the transmitter manufacturer and d is the recommended separation distance in meters (m). Field strength from fixed RF transmitters, as determined by an electromagnetic site survey, ^a should be less than the compliance level in each frequency range. ^b Interference may occur in the vicinity of equipment marked with the following symbol: 
NOTE 1 At 80 MHz and 800 MHz, the higher frequency applies.			
NOTE 2 These guidelines may not apply in all situations. Electromagnetic propagation is affected by absorption and reflection from structures, objects and people.			
^a Field strengths from fixed transmitters, such as base stations for radio (cellular/cordless) telephones and land mobile radios, amateur radio, AM and FM radio broadcast and TV broadcast cannot be predicted theoretically with accuracy. To assess the electromagnetic environment due to fixed RF transmitters, an electromagnetic site survey should be considered. If the measured field strength in the location in which the Centurion is used exceeds the applicable RF compliance level above, the Centurion should be observed to verify normal operation. If abnormal performance is observed, additional measures may be necessary, such as re-orienting or relocating the Centurion unit.			
^b Over the frequency range 150 kHz to 80 MHz, field strengths should be less than 3 V/m.			

12.6 Separation distances for RF devices and Centurion

Recommended separation distances between portable and mobile RF communications equipment and the Centurion by AmeriWater.			
The Centurion by AmeriWater is intended for use in an electromagnetic environment in which radiated RF disturbances are controlled. AmeriWater or your Healthcare Provider will help prevent electromagnetic interference by calculating and maintaining a minimum distance between portable and mobile RF communications equipment (transmitters) and the Centurion unit as recommended below, according to the maximum output power of the communication equipment.			
Rated maximum output power of transmitter W	Separation distance according to frequency of transmitter m		
	150 kHz to 80 MHz $d = [1.17] \sqrt{P}$	80 MHz to 800 MHz $d = [1.17] \sqrt{P}$	800 MHz to 2.5 GHz $d = [2.33] \sqrt{P}$
0.01	0.12	0.12	0.23
0.1	0.37	0.37	0.74
1	1.17	1.17	2.33
10	3.70	3.70	7.37
100	11.70	11.70	23.30
For transmitters rated at a maximum output power not listed above, the recommended separation distance <i>d</i> in meters (m) can be estimated using the equation applicable to the frequency of the transmitter, where <i>P</i> is the maximum output power rating of the transmitter in watts (W) according to the transmitter manufacturer.			
NOTE 1 At 80 MHz and 800 MHz, the higher frequency applies.			
NOTE 2 These guidelines may not apply in all situations. Electromagnetic propagation is affected by absorption and reflection from structures, objects and people.			

12.7 Classification and standards applied

Electrical	Class I Equipment (see Note1)
Overvoltage category – Fixed installation	Category II
Overvoltage category – Permanently installed	Category III
Pollution degree classification	Degree 2
IP Classification	IP21
Medical class - USA	Class II
Medical class - Canada	Class III
Radio Performance - USA	To FCC Part 18 (industrial, Scientific and Medical)
Radio Performance - Canada	To ICES-001 (Industrial, Scientific and Medical (ISM) Radio Frequency Generators.
Designed in general accordance with the requirements of BS EN 60601-1-2 :2007 Medical Electrical Equipment – Part 1-2: general requirements for basic safety and essential performance	



Warning: Note 1, To avoid risk of electric shock, this equipment must be connected to a supply main with protective earth.

13 UNIT OPERATING VALUES

To assist the future performance of the RO unit, the values taken immediately after commissioning while the unit is running in a normal processing condition, should be recorded in the relevant boxes provided below:

Additional Information*	
Serial No.	
Unit ID No.	
Commissioning date.	

Parameter	Unit of measure	Commissioning value*	Acceptance limits
Permeate quality	µS/cm		<100**
Permeate temperature	Degrees F		34-95
Permeate flow (77°F)	UsGals/min		>0.4
Drain flow (77°F)	UsGals/min		0.29
Boost pump pressure (Processing)	bar (psi)		Typically 14 (203)
Feedwater quality	µS/cm		< 2000
Feed temperature	Degrees F		34-95
%Salt Rejection (%SR)	%		>95%
Feedwater pressure	bar (psi)		2-6 bar (30-90)***
Feedwater Total hardness	ppm as CaCO ₃		<400
Feedwater Free Chlorine	ppm as Cl ₂		<0.1

* To be completed by installation engineer during commissioning.

** based on a 2000 µS/cm feed water supply quality.

*** set to 3 bar (45 PSI)

NOTE

Centurion membrane performance is affected by water temperature. The Product Water Flow Rate and Output decreases as the temperature of the Incoming Tap Water decreases. The temperature can affect the product water output by as much as 1.5% to 2.0% per degree Fahrenheit.

14 APPENDIX

14.1 How to use the push-fit connectors

To make a connection, simply push to tube in by hand; the pushfit collet locking system then holds the tube firmly in place without deforming it or restricting flow

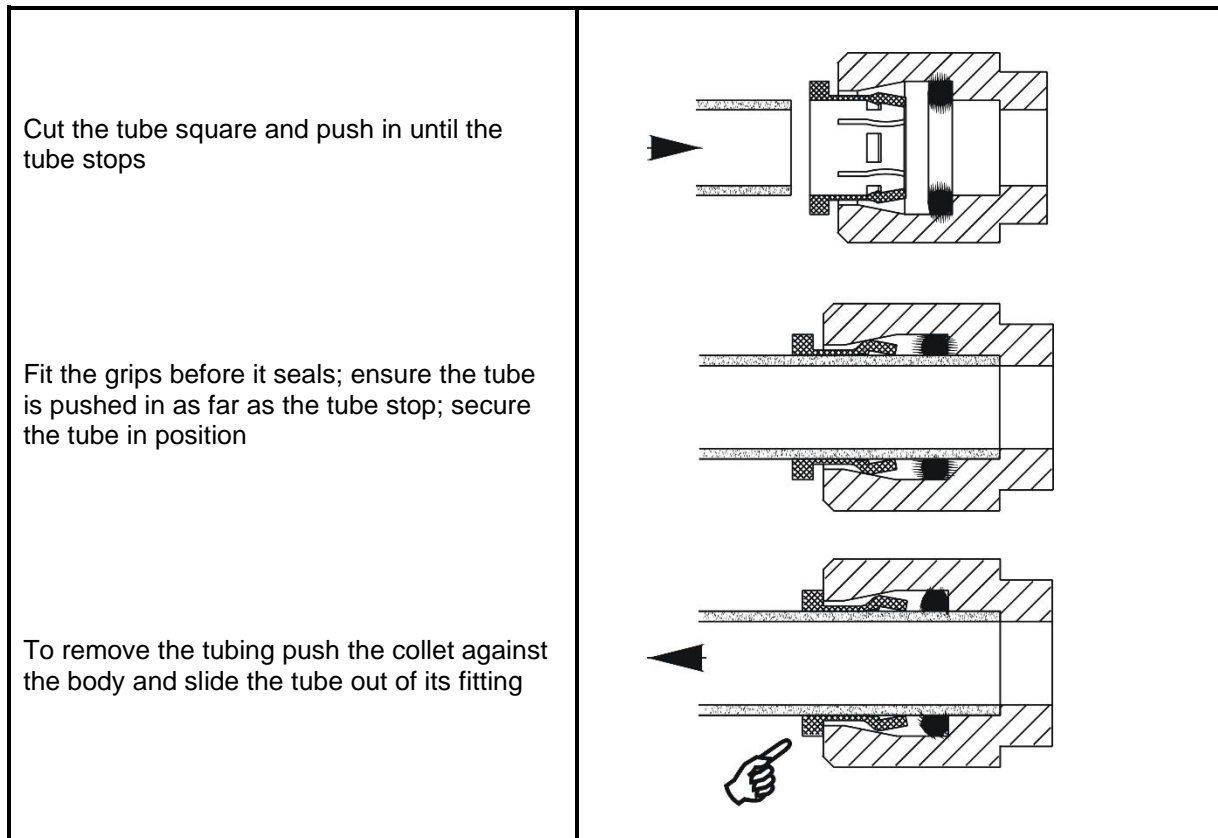

14.2 E-Waste



Disposal of the unit or any electrical component from the unit must be in accordance with local requirements in your province or state for the disposal of electrical waste (E-Waste).

Your healthcare provider will be responsible for the disposal of any such items and for the disposal of the unit if required.

Disposal of the device is the responsibility of the Medical Director of the facility. All local codes and regulations regarding the disposal must be followed. **AmeriWater** recommends that the entire device be cleaned/decontaminated prior to beginning the disposal process. Many of the major components may be eligible for recycling in your area, except for the controller and RO/UF membranes. It is recommended that these items be incinerated.

14.3 Circuit board connection schedule

Inputs	Connector	Pin No.
Key Switch	CON17	Pin 3
Common	CON17	Pin 4
Tilt Switch	CON18	Pin 3
Common	CON18	Pin 4
Tank High Level Switch –	CON19	Pin 3
Common	CON19	Pin 4
Tank Mid Level Switch -	CON20	Pin 3
Tank Low Level Switch -	CON21	Pin 3
Over Temperature Switch	CON22	Pin 3
Common	CON22	Pin 4
Feed Line Cell – Red wire	CON10	Pin 1
Feed Line Cell – Black wire	CON10	Pin 2
Permeate Line Cell – Red wire	CON11	Pin 1
Permeate Line Cell – Black wire	CON11	Pin 2
Common/Screen	CON11	Pin 3
Leak Cell – Red wire	CON12	Pin 1
Leak Cell – Black wire	CON12	Pin 2
Common/Screen	CON12	Pin 3
Ring Thermistor – Red wire	CON4	Pin 1
Common – Blue wire	CON4	Pin 2
Tank Thermistor – Red wire	CON5	Pin 1
Common – Blue wire	CON5	Pin 2
Pressure Transmitter Supply – Brown wire	CON7	Pin 1
Pressure Transmitter Signal – White wire	CON7	Pin 2
Pressure Transmitter Common – Blue wire	CON7	Pin 3
Flow Sensor Supply - Red wire	CON9	Pin 1
Flow Sensor Signal – Brown wire	CON9	Pin 2
Flow Sensor Common – Black wire	CON9	Pin 3
Outputs	Connector	Pin No.
Drain #1 Solenoid 24V Common – Red wire	CON23	Pin 1
Drain #1 Solenoid 0V Switched – Black wire	CON23	Pin 2
Inlet Solenoid 24V Common – Red wire	CON24	Pin 1
Inlet Solenoid 0V Switched – Black wire	CON24	Pin 2
Permeate Solenoid 24V Common – Red wire	CON25	Pin 1

Permeate Solenoid 24V Switched – Black wire	CON25	Pin 2
Draw Solenoid 24V Common – Red wire	CON26	Pin 1
Draw Solenoid 24V Common – Black wire	CON26	Pin 2
Rear Main fan	CON27	Pin 2
Drain #2 Solenoid 24V Common – Red wire	CON28	Pin 1
Drain #2 Solenoid 0V Switched – Black wire	CON28	Pin 2
Heater relay	CON29	Pin 2
Boost Pump control	CON30	Pin 2
+5V	CON39	Pin 1
Fault	CON39	Pin 2
Pump run	CON39	Pin 3
0V	CON39	Pin 4
Speed 0-5V	CON39	Pin 5
0V	CON39	Pin 6
Equalize Solenoid 24V Common – Red wire	CON41	Pin 1
Equalize Solenoid 24V Switched – Black wire	CON41	Pin 2
Blend Solenoid 24V Common – Red wire	CON42	Pin 1
Blend Solenoid 24V Switched – Black wire	CON42	Pin 2
Power Supply	Connector	Pin No.
24Vdc Supply – Red wire	CON7	Pin 1
0Vdc Supply – Black wire	CON7	Pin 2
Alarm	Connector	Pin No.
Alarm Contacts Common	CON7	Pin 1
Alarm Contacts N/C	CON7	Pin 2
Alarm Contacts N/O	CON7	Pin 3

14.4 Flow Schematic

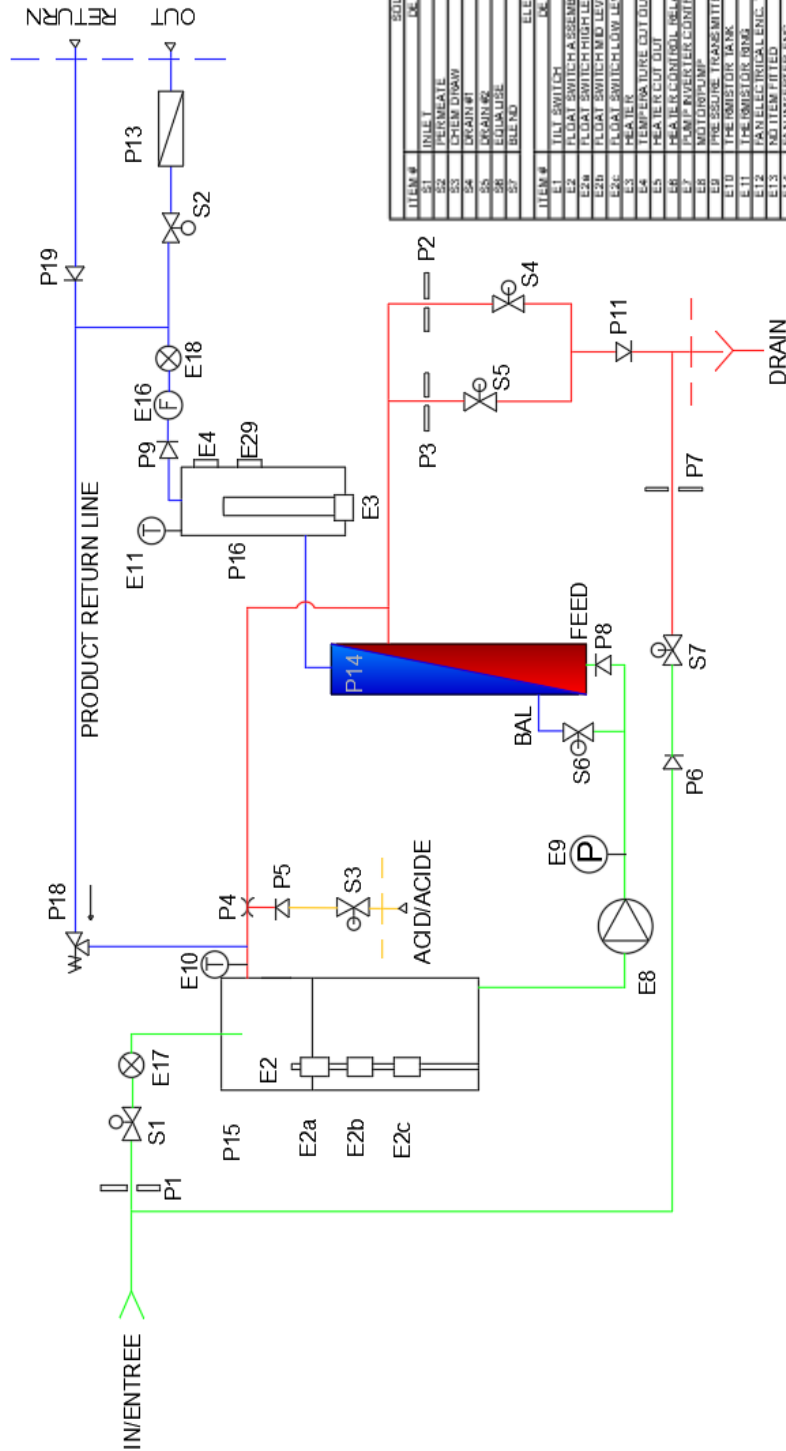

ITEM #	DESCRIPTION	PART #
E1	INLET	R36-0006
E2	PERMATE	R36-0006
E3	CHEM DRAIN	R36-0001
E4	DRAIN #1	R36-0004
E5	DRAIN #2	R36-0009
E6	EDU/DISE	R36-0007
E7	BLENDE	R36-0006
E8		
E9		
E10		
E11	FLAT SWITCH ASSEMBLY	R0135-0001
E12	FLAT SWITCH MIDDLE VEL	R0135-0001
E13	FLAT SWITCH LOW LEVEL	R36-0001
E14	FEATER	
E15	TEMPERATURE COUT OUT	
E16	FEATER COUT OUT	
E17	FEATER CONTROL RELAY	R0082012
E18	FEATER CONTROL RELAY	R0082012
E19	MULTIPLY	R0136-0001
E20	PRE SECOND TANK	
E21	PRE SECOND TANK	
E22	PRE SECOND TANK	
E23	PRE SECOND TANK	
E24	PRE SECOND TANK	
E25	PRE SECOND TANK	
E26	PRE SECOND TANK	
E27	PRE SECOND TANK	
E28	PRE SECOND TANK	
E29	PRE SECOND TANK	
E30	PRE SECOND TANK	
E31	PRE SECOND TANK	
E32	PRE SECOND TANK	
E33	PRE SECOND TANK	
E34	PRE SECOND TANK	
E35	PRE SECOND TANK	
E36	PRE SECOND TANK	
E37	PRE SECOND TANK	
E38	PRE SECOND TANK	
E39	PRE SECOND TANK	
E40	PRE SECOND TANK	
E41	PRE SECOND TANK	
E42	PRE SECOND TANK	
E43	PRE SECOND TANK	
E44	PRE SECOND TANK	
E45	PRE SECOND TANK	
E46	PRE SECOND TANK	
E47	PRE SECOND TANK	
E48	PRE SECOND TANK	
E49	PRE SECOND TANK	
E50	PRE SECOND TANK	
E51	PRE SECOND TANK	
E52	PRE SECOND TANK	
E53	PRE SECOND TANK	
E54	PRE SECOND TANK	
E55	PRE SECOND TANK	
E56	PRE SECOND TANK	
E57	PRE SECOND TANK	
E58	PRE SECOND TANK	
E59	PRE SECOND TANK	
E60	PRE SECOND TANK	
E61	PRE SECOND TANK	
E62	PRE SECOND TANK	
E63	PRE SECOND TANK	
E64	PRE SECOND TANK	
E65	PRE SECOND TANK	
E66	PRE SECOND TANK	
E67	PRE SECOND TANK	
E68	PRE SECOND TANK	
E69	PRE SECOND TANK	
E70	PRE SECOND TANK	
E71	PRE SECOND TANK	
E72	PRE SECOND TANK	
E73	PRE SECOND TANK	
E74	PRE SECOND TANK	
E75	PRE SECOND TANK	
E76	PRE SECOND TANK	
E77	PRE SECOND TANK	
E78	PRE SECOND TANK	
E79	PRE SECOND TANK	
E80	PRE SECOND TANK	
E81	PRE SECOND TANK	
E82	PRE SECOND TANK	
E83	PRE SECOND TANK	
E84	PRE SECOND TANK	
E85	PRE SECOND TANK	
E86	PRE SECOND TANK	
E87	PRE SECOND TANK	
E88	PRE SECOND TANK	
E89	PRE SECOND TANK	
E90	PRE SECOND TANK	
E91	PRE SECOND TANK	
E92	PRE SECOND TANK	
E93	PRE SECOND TANK	
E94	PRE SECOND TANK	
E95	PRE SECOND TANK	
E96	PRE SECOND TANK	
E97	PRE SECOND TANK	
E98	PRE SECOND TANK	
E99	PRE SECOND TANK	
E100	PRE SECOND TANK	
P1	FLOW RES INDUCTOR INLET	
P2	FLOW RES INDUCTOR DRAIN 1	
P3	FLOW RES INDUCTOR DRAIN 2	
P4	CHEMICAL EDUCTOR	
P5	NON RETURN VALVE CHEM DRAIN	
P6	NON RETURN VALVE BLEND 1	
P7	NON RETURN VALVE BLEND 2	
P8	NON RETURN VALVE BLEND 3	
P9	NON RETURN VALVE PERMATE	
P10	NON RETURN VALVE DRAIN	
P11	NON RETURN VALVE DRAIN	
P12	NON RETURN VALVE DRAIN	
P13	NON RETURN VALVE DRAIN	
P14	NON RETURN VALVE DRAIN	
P15	NON RETURN VALVE DRAIN	
P16	NON RETURN VALVE DRAIN	
P17	NON RETURN VALVE DRAIN	
P18	NON RETURN VALVE DRAIN	
P19	NON RETURN VALVE DRAIN	
P20	NON RETURN VALVE DRAIN	
P21	NON RETURN VALVE DRAIN	
P22	NON RETURN VALVE DRAIN	
P23	NON RETURN VALVE DRAIN	
P24	NON RETURN VALVE DRAIN	
P25	NON RETURN VALVE DRAIN	
P26	NON RETURN VALVE DRAIN	
P27	NON RETURN VALVE DRAIN	
P28	NON RETURN VALVE DRAIN	
P29	NON RETURN VALVE DRAIN	
P30	NON RETURN VALVE DRAIN	
P31	NON RETURN VALVE DRAIN	
P32	NON RETURN VALVE DRAIN	
P33	NON RETURN VALVE DRAIN	
P34	NON RETURN VALVE DRAIN	
P35	NON RETURN VALVE DRAIN	
P36	NON RETURN VALVE DRAIN	
P37	NON RETURN VALVE DRAIN	
P38	NON RETURN VALVE DRAIN	
P39	NON RETURN VALVE DRAIN	
P40	NON RETURN VALVE DRAIN	
P41	NON RETURN VALVE DRAIN	
P42	NON RETURN VALVE DRAIN	
P43	NON RETURN VALVE DRAIN	
P44	NON RETURN VALVE DRAIN	
P45	NON RETURN VALVE DRAIN	
P46	NON RETURN VALVE DRAIN	
P47	NON RETURN VALVE DRAIN	
P48	NON RETURN VALVE DRAIN	
P49	NON RETURN VALVE DRAIN	
P50	NON RETURN VALVE DRAIN	
P51	NON RETURN VALVE DRAIN	
P52	NON RETURN VALVE DRAIN	
P53	NON RETURN VALVE DRAIN	
P54	NON RETURN VALVE DRAIN	
P55	NON RETURN VALVE DRAIN	
P56	NON RETURN VALVE DRAIN	
P57	NON RETURN VALVE DRAIN	
P58	NON RETURN VALVE DRAIN	
P59	NON RETURN VALVE DRAIN	
P60	NON RETURN VALVE DRAIN	
P61	NON RETURN VALVE DRAIN	
P62	NON RETURN VALVE DRAIN	
P63	NON RETURN VALVE DRAIN	
P64	NON RETURN VALVE DRAIN	
P65	NON RETURN VALVE DRAIN	
P66	NON RETURN VALVE DRAIN	
P67	NON RETURN VALVE DRAIN	
P68	NON RETURN VALVE DRAIN	
P69	NON RETURN VALVE DRAIN	
P70	NON RETURN VALVE DRAIN	
P71	NON RETURN VALVE DRAIN	
P72	NON RETURN VALVE DRAIN	
P73	NON RETURN VALVE DRAIN	
P74	NON RETURN VALVE DRAIN	
P75	NON RETURN VALVE DRAIN	
P76	NON RETURN VALVE DRAIN	
P77	NON RETURN VALVE DRAIN	
P78	NON RETURN VALVE DRAIN	
P79	NON RETURN VALVE DRAIN	
P80	NON RETURN VALVE DRAIN	
P81	NON RETURN VALVE DRAIN	
P82	NON RETURN VALVE DRAIN	
P83	NON RETURN VALVE DRAIN	
P84	NON RETURN VALVE DRAIN	
P85	NON RETURN VALVE DRAIN	
P86	NON RETURN VALVE DRAIN	
P87	NON RETURN VALVE DRAIN	
P88	NON RETURN VALVE DRAIN	
P89	NON RETURN VALVE DRAIN	
P90	NON RETURN VALVE DRAIN	
P91	NON RETURN VALVE DRAIN	
P92	NON RETURN VALVE DRAIN	
P93	NON RETURN VALVE DRAIN	
P94	NON RETURN VALVE DRAIN	
P95	NON RETURN VALVE DRAIN	
P96	NON RETURN VALVE DRAIN	
P97	NON RETURN VALVE DRAIN	
P98	NON RETURN VALVE DRAIN	
P99	NON RETURN VALVE DRAIN	
P100	NON RETURN VALVE DRAIN	
S1	NON RETURN VALVE DRAIN	
S2	NON RETURN VALVE DRAIN	
S3	NON RETURN VALVE DRAIN	
S4	NON RETURN VALVE DRAIN	
S5	NON RETURN VALVE DRAIN	
S6	NON RETURN VALVE DRAIN	
S7	NON RETURN VALVE DRAIN	
S8	NON RETURN VALVE DRAIN	
S9	NON RETURN VALVE DRAIN	
S10	NON RETURN VALVE DRAIN	
S11	NON RETURN VALVE DRAIN	
S12	NON RETURN VALVE DRAIN	
S13	NON RETURN VALVE DRAIN	
S14	NON RETURN VALVE DRAIN	
S15	NON RETURN VALVE DRAIN	
S16	NON RETURN VALVE DRAIN	
S17	NON RETURN VALVE DRAIN	
S18	NON RETURN VALVE DRAIN	
S19	NON RETURN VALVE DRAIN	
S20	NON RETURN VALVE DRAIN	
S21	NON RETURN VALVE DRAIN	
S22	NON RETURN VALVE DRAIN	
S23	NON RETURN VALVE DRAIN	
S24	NON RETURN VALVE DRAIN	
S25	NON RETURN VALVE DRAIN	
S26	NON RETURN VALVE DRAIN	
S27	NON RETURN VALVE DRAIN	
S28	NON RETURN VALVE DRAIN	
S29	NON RETURN VALVE DRAIN	
S30	NON RETURN VALVE DRAIN	
S31	NON RETURN VALVE DRAIN	
S32	NON RETURN VALVE DRAIN	
S33	NON RETURN VALVE DRAIN	
S34	NON RETURN VALVE DRAIN	
S35	NON RETURN VALVE DRAIN	
S36	NON RETURN VALVE DRAIN	
S37	NON RETURN VALVE DRAIN	
S38	NON RETURN VALVE DRAIN	
S39	NON RETURN VALVE DRAIN	
S40	NON RETURN VALVE DRAIN	
S41	NON RETURN VALVE DRAIN	
S42	NON RETURN VALVE DRAIN	
S43	NON RETURN VALVE DRAIN	
S44	NON RETURN VALVE DRAIN	
S45	NON RETURN VALVE DRAIN	
S46	NON RETURN VALVE DRAIN	
S47	NON RETURN VALVE DRAIN	
S48	NON RETURN VALVE DRAIN	
S49	NON RETURN VALVE DRAIN	
S50	NON RETURN VALVE DRAIN	
S51	NON RETURN VALVE DRAIN	
S52	NON RETURN VALVE DRAIN	
S53	NON RETURN VALVE DRAIN	
S54	NON RETURN VALVE DRAIN	
S55	NON RETURN VALVE DRAIN	
S56	NON RETURN VALVE DRAIN	
S57	NON RETURN VALVE DRAIN	
S58	NON RETURN VALVE DRAIN	
S59	NON RETURN VALVE DRAIN	
S60	NON RETURN VALVE DRAIN	
S61	NON RETURN VALVE DRAIN	
S62	NON RETURN VALVE DRAIN	
S63	NON RETURN VALVE DRAIN	
S64	NON RETURN VALVE DRAIN	
S65	NON RETURN VALVE DRAIN	
S66	NON RETURN VALVE DRAIN	
S67	NON RETURN VALVE DRAIN	
S68	NON RETURN VALVE DRAIN	
S69	NON RETURN VALVE DRAIN	
S70	NON RETURN VALVE DRAIN	
S71	NON RETURN VALVE DRAIN	
S72	NON RETURN VALVE DRAIN	
S73	NON RETURN VALVE DRAIN	
S74	NON RETURN VALVE DRAIN	
S75	NON RETURN VALVE DRAIN	
S76	NON RETURN VALVE DRAIN	
S77	NON RETURN VALVE DRAIN	
S78	NON RETURN VALVE DRAIN	
S79	NON RETURN VALVE DRAIN	
S80	NON RETURN VALVE DRAIN	
S81	NON RETURN VALVE DRAIN	
S82	NON RETURN VALVE DRAIN	
S83	NON RETURN VALVE DRAIN	
S84	NON RETURN VALVE DRAIN	
S85	NON RETURN VALVE DRAIN	
S86	NON RETURN VALVE DRAIN	
S87	NON RETURN VALVE DRAIN	
S88	NON RETURN VALVE DRAIN	
S89	NON RETURN VALVE DRAIN	
S90	NON RETURN VALVE DRAIN	
S91	NON RETURN VALVE DRAIN	
S92	NON RETURN VALVE DRAIN	
S93	NON RETURN VALVE DRAIN	
S94	NON RETURN VALVE DRAIN	
S95	NON RETURN VALVE DRAIN	
S96	NON RETURN VALVE DRAIN	
S97	NON RETURN VALVE DRAIN	
S98	NON RETURN VALVE DRAIN	
S99	NON RETURN VALVE DRAIN	
S100	NON RETURN VALVE DRAIN	

14.5 Electrical Schematic

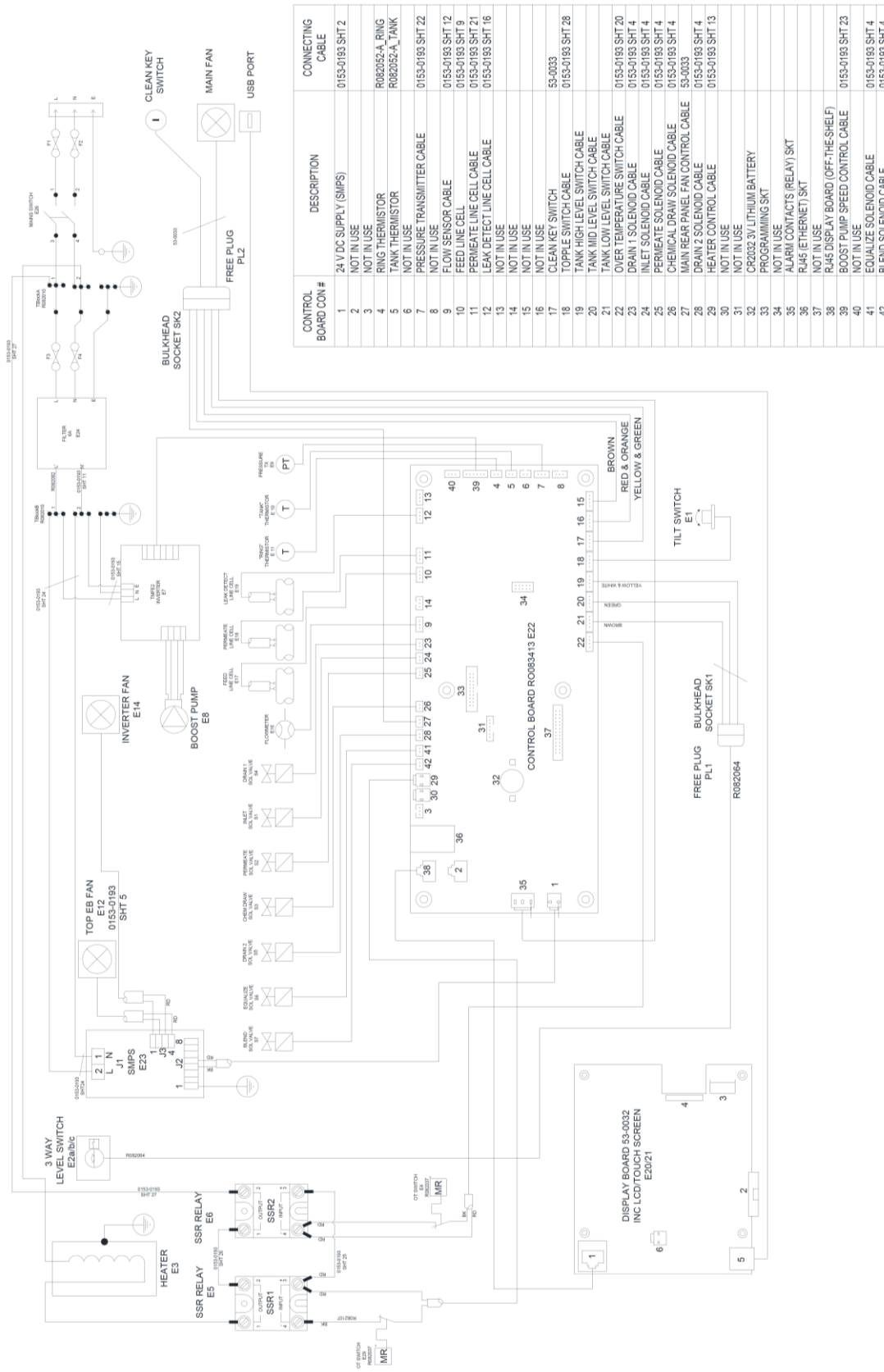

CALIFORNIA PROPOSITION 65

 WARNING

This product can expose you to chemicals such as vinyl chloride (used in the production of PVC) or Nickel (used in the production of stainless steel), that are known to the State of California to cause cancer. For more information go to www.P65Warnings.ca.gov.

Dear Valued Customer,

California Proposition 65 (Prop 65) is the Safe Water and Toxic Enforcement Act of 1986. The State of California began enforcing amendments to California Prop 65 at the end of August 2018. Prop 65 requires manufacturers to provide a clear and reasonable warning to residents of California about chemicals used in products that they purchase that are included on the Prop 65 Chemical List. The chemicals included on the list are chemicals that are known to the State of California to cause cancer, birth defects, or other reproductive harm. One such chemical is Vinyl Chloride, a compound used to produce Polyvinyl Chloride (PVC). The AmeriWater system you have purchased may contain PVC or stainless steel parts.

While warnings are only required in the State of California, AmeriWater has initiated the use of Prop 65 labeling for all products to ensure compliance with California regulations. Please note that the above warning does not necessarily mean that the product that you have purchased is unsafe. Products that have been cleared for market by FDA have been determined to be safe and effective by the United States Food and Drug Administration. The warning is simply a requirement by the State of California. If you wish to obtain additional information, please visit: p65warnings.ca.gov. You may also contact your AmeriWater representative if you have any questions.

Thank you for your understanding and we look forward to continuing to serve you.