

High Efficiency Sand Filter Model CWFT



Table of Contents

1	GENERAL INFORMATION	3
1.1	Introduction	3
2	HEALTH & SAFETY	3
2.1	Cautionary Symbols (look for additional labels)	3
2.2	User Warning	3
3	ABOUT.....	3
3.1	Theory of Operation.....	3
3.2	Specifications	4
3.3	Environmental/Transport	4
4	INSTALLATION & COMMISSIONING	5
4.1	Installation	5
4.2	System Start-Up	7
4.3	System Operation	7
4.4	Monitoring	8
4.5	Maintenance	8
4.5.1	Media Bed Replacement.....	8
4.5.2	CWFT Power Outage Behavior	9
5	TECHNICAL INFORMATION	9
5.1	User Interface	9
5.2	Controller Inputs/Outputs	9
5.3	Modes of Operation.....	11
6	Operator Interface	12
6.1	HMI Map	12
6.2	Settings.....	13
6.3	Functions and Monitoring Available Through the HMI Menu	14
6.4	hmi screens	15
7	ALARMS.....	24
8	Component Information and Schematics	26
8.1	Component Identification	26
8.2	Electrical Schematic	27
8.3	Flow Schematic	28

8.3.1	Mechanical Component Identification	28
8.3.2	Service	29
8.3.3	Backwash – City Water.....	30
8.3.4	Backwash – System Water	31
8.3.5	Drain.....	32
9	TROUBLESHOOTING	33
10	SPARE PARTS LISTING.....	38
10.1	Inlet Plumbing	38
10.2	Pre-Filter Plumbing	39
10.3	Post-Filter Plumbing.....	40
10.4	Backwash Plumbing	41
10.5	Miscellaneous	42
11	APPENDIX	43
11.1	Warranty Information.....	43

1 GENERAL INFORMATION

1.1 Introduction

The AmeriWater CWFT Sand Filter System is designed to filter a small portion of recirculating cooling tower system water. Your CWFT system was thoroughly tested and in excellent condition when it was shipped to you. However, because damage during shipment is possible, please unpack and carefully inspect your system as soon as it is received by you. Please notify AmeriWater if you have any questions, or if any problems are encountered.

2 HEALTH & SAFETY

2.1 Cautionary Symbols (look for additional labels)



Earth Ground Terminal



Denotes unsuitable location for moving system



Denotes suitable location for moving system with a pallet jack/forklift

Consult factory or Component Ratings for Chemical Compatibility when using additives in the system. Incompatible chemicals will damage the unit and can cause system failure.

3 ABOUT

3.1 Theory of Operation

The AmeriWater CWFT Sand Filter system filters out suspended solids in cooling tower water loops via straining mechanisms. Straining occurs when suspended solids are physically blocked by filtration media bed particles.

The removal of suspended solids in cooling water systems improves heat transfer, reduces microbiological activity, improves chemical treatment efficiency, and helps prevent corrosion. The CWFT also has a backwash mode in which flow is reversed through the media bed and the suspended solids filtered out are washed to the drain resulting in a clean media bed.

3.2 Specifications

Maximum incoming water pressure (pressure at pump suction): 60 psi (414 kPa)

City water pressure (if city water backwash source used): 40-70 psi (276 - 483 kPa)

Maximum system water temperature: 110°F (43°C)

Nominal filtration rating: 0.5 or 2 micron (depending on model)

Backwash flowrate/duration: 30 gpm (6.8 m³/hr) /User Selectable between 5 to 15 minutes (Factory set to 5)

Electrical power requirement: 3 phase, 208VAC or 460VAC

3.3 Environmental/Transport

Intended Location for Use	Indoors
Altitude [m]	Up to 2000
Ambient Temperature range [°C]	5-40
Relative Humidity	80% up to 31 °C decreasing linearly to 50% at 40 °C
Mains Supply Voltage Fluctuation	±10% of the nominal voltage

4 INSTALLATION & COMMISSIONING

4.1 Installation

- 1) Using a pallet jack or forklift, move the AmeriWater CWFT into the desired position.
Be sure to lift the unit from the end with the "LIFT HERE" label.
- 2) Plumb the unit per the following figure:

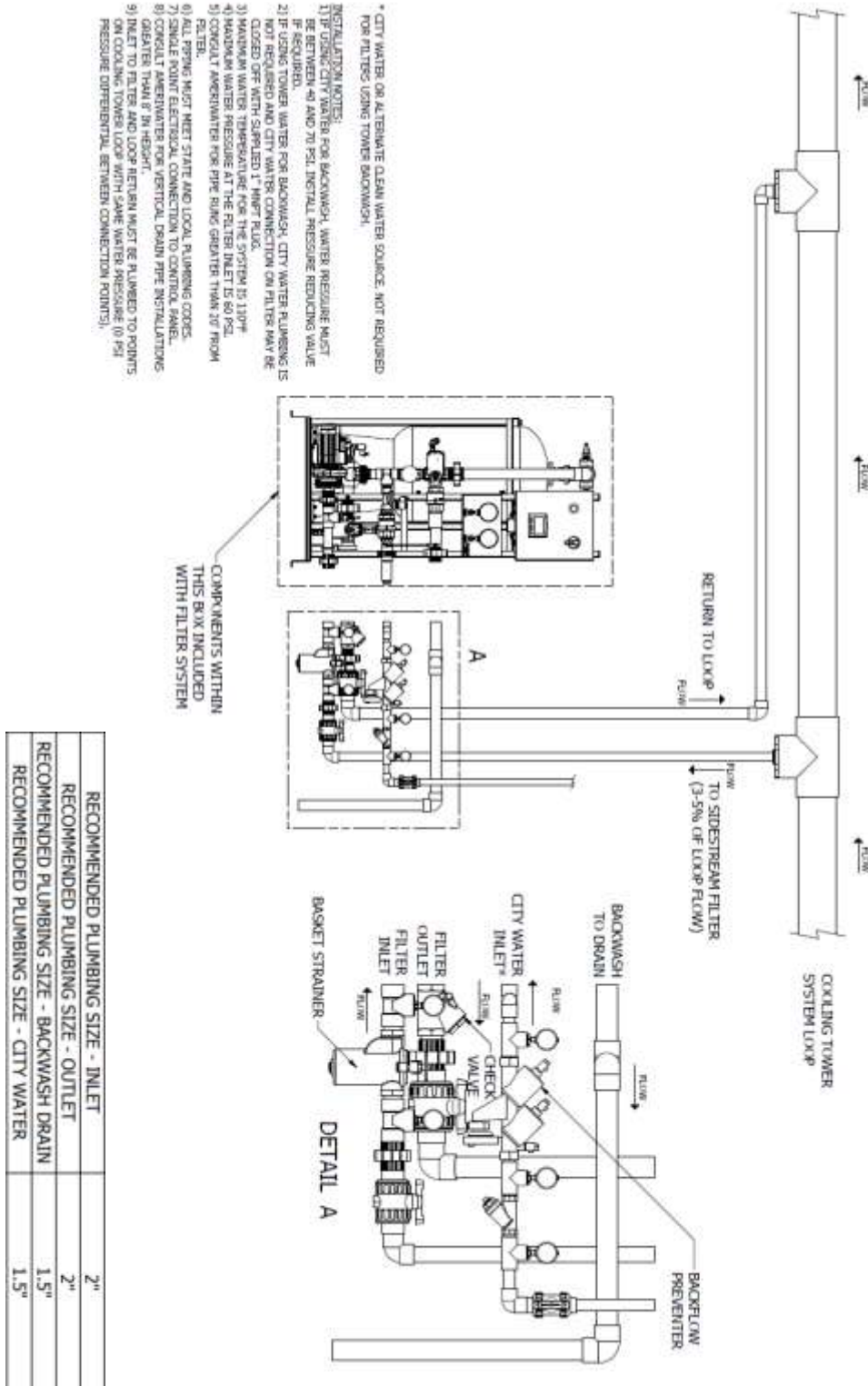

- 3) If coupling the CWFT with an AmeriWater backwash storage tank, move the storage tank into the desired location and plumb from the filter drain to the backwash tank inlet. Next, plumb from the storage tank drain to a floor drain. See wiring steps further on in these instructions on wiring the storage tank float switch into the CWFT control panel.
- 4) Load the filtration media into the tank:
 - a. Loosen the two 2" unions on the top of the tank.
 - b. Rotate the plumbing out of the way. Unthread the 4"x2" bushing on the top of the tank.
 - c. Fill the tank roughly 1/3 of the way with water. Load the media into the top of the tank per the following tables (place top row into the tank first, followed by 2nd row, etc.):

0.5 Micron

Media Type/AmeriWater Part Number	Qty.
1/2 x 1/4 /33-0050	2
3/16 x 10/33-0040	1
Torpedo Sand/33-0080	1
#0/33-0025	1
#00/33-0020	1
#000/33-0015	1

2 Micron

Media Type/AmeriWater Part Number	Qty.
1/2 x 1/4 /33-0050	2
3/16 x 10/33-0040	1
Torpedo Sand/33-0080	1
#0/33-0025	2
#00/33-0020	2

IMPORTANT NOTE: The media used in the AmeriWater CWFT is Silica-Based. Ensure that proper PPE for handling Silica dust is worn during media loading.

- d. Level each media bag in the tank after loading it.
- e. Completely fill tank with water and let media soak at least 24 hours.
- 5) Rotate plumbing back into position and tighten unions on the top of the tank.
- 6) Ensure that wires being used to connect to the CWFT system to electrical power are not energized. Wire the system into the local disconnect with the appropriate 3 phase power source.
- 7) Wire the following into the panel:
 - a. If monitoring motor overload and contactor error warning conditions remotely, wire into terminal block 21 in the control panel to the remote monitoring station. Use appropriate gauge of wire for the wire length and voltage (24 VDC).
 - b. If monitoring backwash condition remotely, wire into terminal blocks 25 and 26. This is a dry contact so voltage must be provided. Voltage must be between 12-250 VAC/VDC, with the current in this circuit being between 10mA-6A.

- c. If using an AmeriWater backwash storage tank, wire the float switch to terminal blocks 10 and 11.
 - d. If installing a Remote Pump Disable dry contact wire one wire into terminal blocks 9 and 12.
 - e. Install strain reliefs in the panel as required for wiring into it.
- 8) Energize the system.
 - 9) Check pump rotation to ensure that the pump is rotating with the arrow on the casing. To do this, simply use the touchscreen to energize the pump momentarily and note the direction of rotation. If the pump is rotating the wrong direction, remove power from the system and incoming wiring and swap the wiring locations of any two phases of the 3-phase power wiring to the local panel disconnect.
 - 10) Re-energize the system and ensure the pump is rotating the proper direction.
 - 11) After the system is energized and the HMI displays the "Operation Menu – Page 1" screen, navigate to the Maintenance Menu and choose the appropriate backwash source that is compatible with the system installation plumbing.
 - 12) Choose correct method of setting backwash time, schedule, time, daily or weekly in the Maintenance Menu.

4.2 System Start-Up

- 1) Perform a 45 minute Installation Backwash via the Maintenance Menu.
 - a. During initial backwash the water will be cloudy/dirty. The longer the unit backwashes, the water should transition to clean water through the sight glass.
- 2) The system is now ready to be placed into Service. To place the system into Service:
 - a. Close the system throttling valve completely.
 - b. Ensure the throttling valve to the system is open and change the Pump Mode to Auto on the "Operation Menu – Page 1" screen.
 - c. Begin to very slowly open the system throttling valve to allow water to enter the top of the tank and begin being filtered through the media bed. Monitor the differential pressure across the media bed as Pre-Filter Pressure minus Post-Filter Pressure.
 - d. Continue to open the Throttling valve until the differential pressure across the media bed is approximately 10 psi. Note that the throttling valve may not be fully open in order to achieve this differential pressure.
- 3) The system is now fully installed and is filtering a small portion of the cooling tower loop water.
- 4) In certain applications the throttling valve needs to be fully open after a few days. In these applications use the following steps:
 - a. Perform a backwash daily.
 - b. Open the throttling valve a bit more if the differential pressure is less than 10 PSI, until the valve is fully open.

4.3 System Operation

Once the CWFT system is installed and placed into service, it will filter a portion of cooling tower loop water at a nominal flowrate of 45 gpm (6.8 m³/hr) at a nominal filtration rating of 0.5 or 2 micron depending on the system installed. Water is drawn into the filter by the system booster pump, forced through the media bed, and reintroduced to the cooling tower loop. As the system runs and filtered particles are lodged into the media bed, the differential pressure will begin to increase across the bed due to frictional losses. Once the differential pressure reaches 18 psi (124 kPa), the differential pressure switch will close and the system will enter Backwash Mode. In Backwash Mode flow is reversed through the system and water enters through valve 2, runs the reverse direction through the media bed, and

washes the filtered particles through valve 1 and to drain. Once the backwash is completed, the system will re-enter Service mode in which it is filtering water. The system will also backwash via a 24 hour or 7 day (depending on the timer backwash setting) timer in the PLC software, regardless of the number of differential pressure backwashes that have occurred since the previous timer backwash. If the CWFT is coupled with an AmeriWater backwash storage tank, the storage tank will fill with backwash water until the float switch is rotated by the upper surface of the water and closes when the tank is nearly full. If this happens, the backwash will be automatically aborted to prevent the tank from overflowing.

4.4 Monitoring

Limited remote monitoring and control is available on the AmeriWater CWFT. If any of the outputs available to the customer have been wired into, these can be used to monitor the system. These include the following:

- 1) System in Backwash – Dry contact which closes whenever the unit is in backwash. Wire into terminal blocks 25 and 26 to tie into this circuit.
- 2) Pump remote disable – Input to the PLC which prevents the pump from running. Wire remote pump switch (dry contact) between terminals 9 and 12 in order to remotely disable the pump. When the associated input on the PLC is energized, the pump will be disabled.
- 3) Generic warning – Output on the PLC which energizes at 24VDC when a motor contactor error or motor overload condition is present. Wire into terminal block 21 to tie into this circuit.

4.5 Maintenance

4.5.1 *Media Bed Replacement*

Media to be inspected and topped off every 6 months. It is recommended that the media bed be replaced every 3-5 years. To replace the media bed:

- 1) Change the Pump Mode to Off.
- 2) Isolate the CWFT system from the loop using the isolation valves on the inlet and outlet of the system.
- 3) Manually open the Tank Drain Vacuum Break Valve on the top of the system
- 4) Then, using the Tank Drain feature on the system, drain the tank of water.
- 5) Once the tank is drained, close the throttling valve on the system fully.
- 6) End Tank Drain.
- 7) Disconnect power from the unit with the local disconnect on the control panel. (Use proper Lock Out/Tag Out Procedures)
- 8) Loosen the unions on top of the tank and unthread the 4" bushing. Rotate piping out of the way.
- 9) Using a vacuum attached to a drum, remove the existing media from the tank. Be sure to use appropriate PPE for working with Silica-Based media.
- 10) Once the previous media has been removed, place a funnel in the top opening of the tank.
- 11) Fill the tank roughly 1/3 of the way with water.
- 12) Fill the CWFT tank with the appropriate media pack for the system (either 0.5 or 2 micron). Level each media bag in tank after loading.
- 13) Completely fill tank with water and let media soak for at least 24 hours.
- 14) Replace the plumbing and tube connections on top of the tank.
- 15) Open the isolation valves on the inlet and outlet of the system.
- 16) Turn the local disconnect to the ON position.
- 17) Change the Pump Mode to Auto.
- 18) Perform a 45 minute Installation Backwash.

- 19) Once the Installation Backwash is complete and the system goes back into Service, slowly begin to open the system throttling valve until the differential pressure across the media bed is roughly 10 psi.

4.5.2 CWFT Power Outage Behavior

If there is a power outage or the local disconnect is turned to the Off position, the CWFT unit will exhibit the following behavior upon being re-energized:

- 3-way actuated ball valves (Valves #1 and #2) go to a home position of Service
- Backwash Source setting is retained
- Timer Backwash period setting is retained
- Pump Mode defaults to the Off position

5 TECHNICAL INFORMATION

5.1 User Interface

The user interface is an HMI touchscreen with a 4.3" size screen. The user can navigate through the different menus via the buttons on the touchscreen to change settings, operations modes, and monitor activity. For a detailed map of the user interface, see the figure in Section 6.1.

5.2 Controller Inputs/Outputs

Input/Output	Item	Address (PLC Address/PLC Terminal Strip Address)	Description
Input	Differential Pressure Switch	I0/15	Energized when the system differential pressure switch closes at 18 psi (124 kPa).
Input	E-Stop Button	I1/14	De-energized when E-Stop button on the front of the system panel is pressed.
Input	Pump Motor Overload	I2/13	Energized when the motor overload relay closes due to an excessive current draw by the motor.
Input	Pump Motor Contactor Confirmation	I3/12	Energized when the pump motor circuit is closed.
Input	System Inlet Pressure Switch	I4/11	De-energized if the system inlet pressure is > 40 psi. This prevents the pump from unnecessarily running during backwash if the backwash source is System Water.
Input	Remote Pump Disable	I5/10	Pump is disabled if energized.
Input	Backwash Storage Tank Float Switch	I6/9	Energized when the backwash storage tank float switch closes. The backwash aborts if energized.

Output	Pump Run signal	O0/6	Pump runs if energized.
Output	Valve 1 to Backwash Position	O1/7	Valve 1 rotates to backwash position while energized. Valve remains energized during backwash. At the end of backwash, the signal is removed and the valve is spring-returned to Service position.
Output	Valve 2 to Backwash Position	O2/8	Valve 2 rotates to backwash position while energized. Valve remains energized during backwash. At the end of backwash, the signal is removed and the valve is spring-returned to Service position.
Output	Generic Warning Output	O3/9	Energized when a motor overload or motor contactor error condition is active
Output	Drain Solenoid Valve	O4/11	Energized to open drain solenoid during Tank Drain
Output	System Water Backwash Solenoid Valve	O5/12	Energized to open the backwash solenoid valve during backwash when System Water is selected as the backwash source
Output	Unit in Backwash Output	O6/13	Energized when the system is backwashing

5.3 Modes of Operation

Service – In this mode of operation, a small portion of the water flow of the cooling tower loop is being filtered and reintroduced to the loop.

Backwash – In this mode of operation, water flow is reversed through the filter in order to wash filtered suspended particles to the drain. There are different ways in which a backwash can be initiated:

- On-Demand – This occurs when the differential pressure across the media bed reaches 18 psi (124 kPa)
- Timer – The system backwashes every 24 hours or 7 days as selected by the user as an option in the Maintenance Menu
- Manual – A manual backwash can be initiated via the touchscreen in the Maintenance Menu

The source of backwash water can be either city water or cooling tower system water. The backwash source is user selectable in the Maintenance Menu and must be compatible with the way the system is plumbed. If City Water is selected, an appropriate city water supply must be plumbed into the city water connection on the filter. If System Water is selected, the city water connection on the filter must be plugged with the supplied 1" MNPT plug. See Section 4, Installation & Commissioning, for more information.

Tank Drain – This mode of operation allows the tank to be drained via the drain solenoid valve for maintenance or filter system relocation. In this mode of operation the system stops filtering water and Valve #1 moves into backwash position. The drain solenoid valve then opens to allow the tank to drain. The valve at the top of the tank serves as a vacuum breaker during tank drain. When the operator determines the tank has been emptied, Tank Drain Vacuum Break Valve must be manually closed, Tank Drain can be ended, and the unit returns to Service. It is important to note that a user must manually open and close the vacuum break before and after Tank Drain functions are enacted on the system. **Note:** Before Tank Drain is enacted, a user must open the manual Tank Drain Vacuum Break Valve.

Before End Tank Drain is enacted, a user must close the manual Tank Drain Vacuum Break Valve.

Refer to the schematics in Section 8 for the positions of valves and the water flow paths during the different modes of operation.

6 OPERATOR INTERFACE

6.1 HMI Map

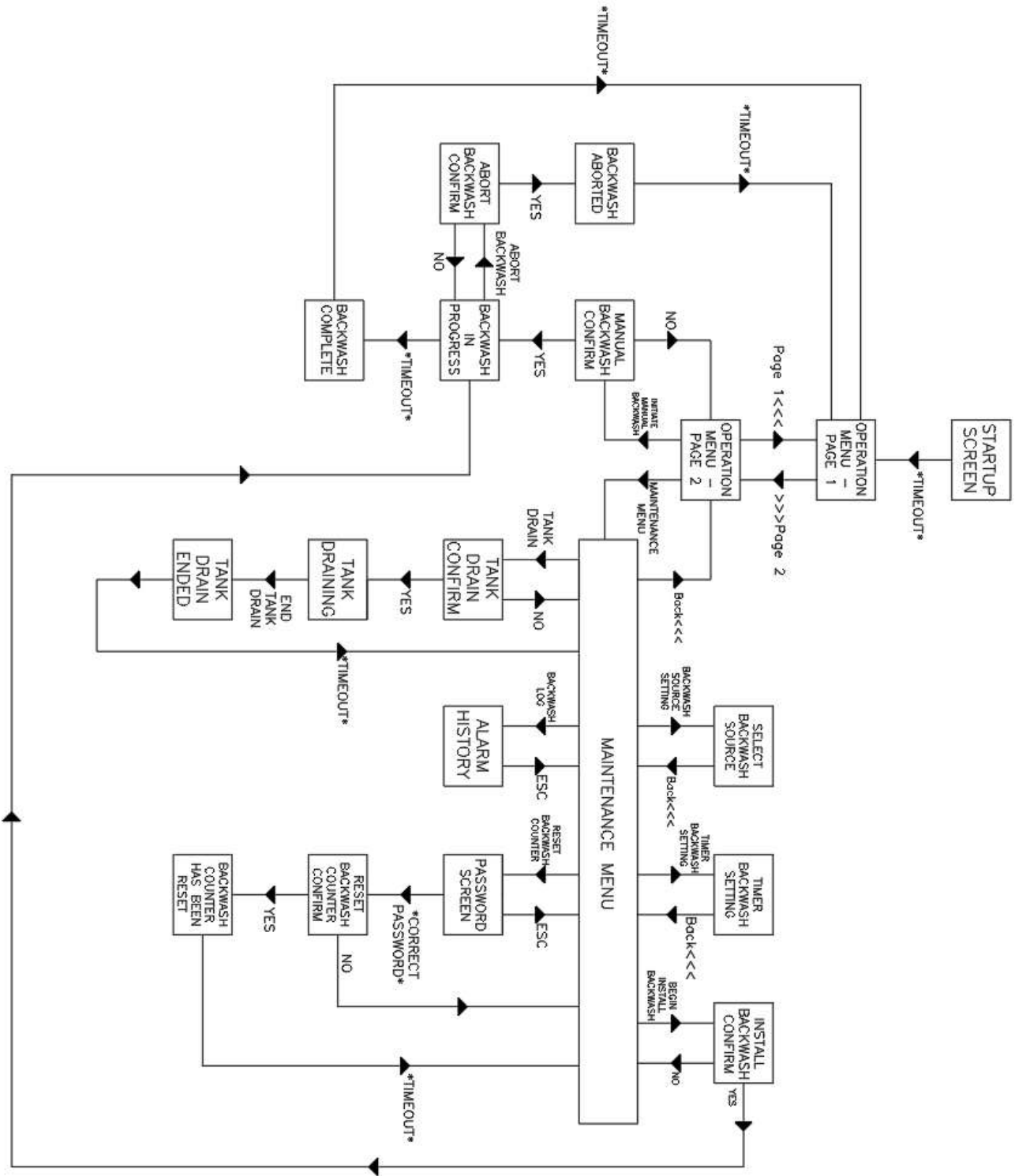

Description of the HMI Map on previous page:

- Boxes denote HMI screens
- An arrow pointing towards a screen denotes that there is a button on the HMI which takes it from the upstream to the downstream screen
- Button names as shown on the HMI are written next to the arrow associated with it
- *TIMEOUT* denotes that the screen upstream from this text will timeout to the screen downstream of it based on timers in the PLC program
- *CORRECT PASSWORD* denotes that a correct password takes the user to the downstream screen

6.2 Settings

Setting	Option	Description	Location
Pump Mode	Auto	Pump runs as commanded by PLC	Operation Menu – Page 1
	Off*	Pump does not run	
Backwash Source	City Water	Backwash source is city water. Pump does not run during backwash and backwash solenoid stays closed during backwash	Select Backwash Source
	System Water	Backwash source is system water. Pump runs during backwash if system water < 40 psi. Backwash solenoid opens during backwash	
Timer Backwash	24 Hour	The system will be put into a timer backwash every 24 hours	Timer Backwash Setting
	7 Day	The system will be put into a timer backwash every 7 days	

*Denotes default setting upon power-up

6.3 Functions and Monitoring Available Through the HMI Menu

Item	Description	Location
Manual Backwash Initiation	Allows the user to start a backwash manually without the need for an 18 psi (124 kPa) media bed pressure differential	Operation Menu – Page 2
Startup Backwash Initiation	Allows the installer to put the unit into a 45 minute backwash in order to clean the media bed of dust and debris during installation and startup	Maintenance Menu
Backwash Log (HMI screen titled “Alarm History”)	Allows the user to see when backwashes have taken place and also to see the type of backwash. The type of backwash will be displayed in the ID field on this screen	Maintenance Menu
Reset Backwash Counter	This function is for production purposes only and is password protected. Allows the backwash counter in the bottom-left corner of the HMI to be reset to 0	Maintenance Menu
Tank Drain	Allows the user to drain the pressure vessel of water so that the system can be serviced and moved more easily	Maintenance Menu

6.4 hmi screens

The screen title is at the top of each screen. See section 6.1 for help navigating the screens. See section 6.2 for explanations of each setting option. See section 6.3 for descriptions of the monitored items.

START- UP DISPLAY SCREEN



OPERATION MENU – PAGE 1 SCREEN

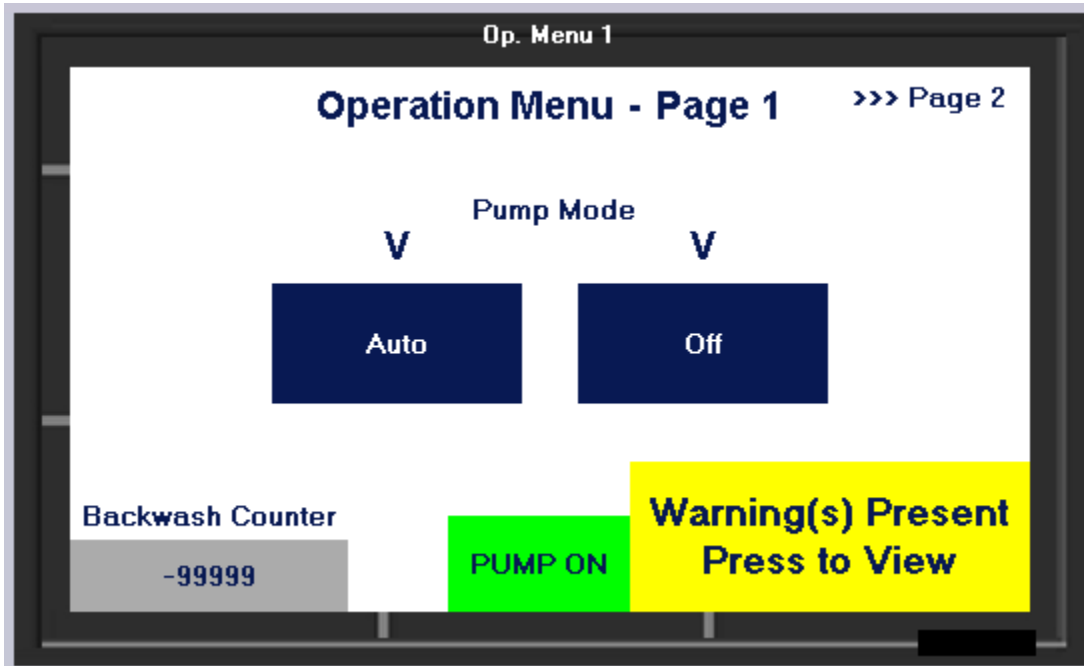

WARNING SCREEN

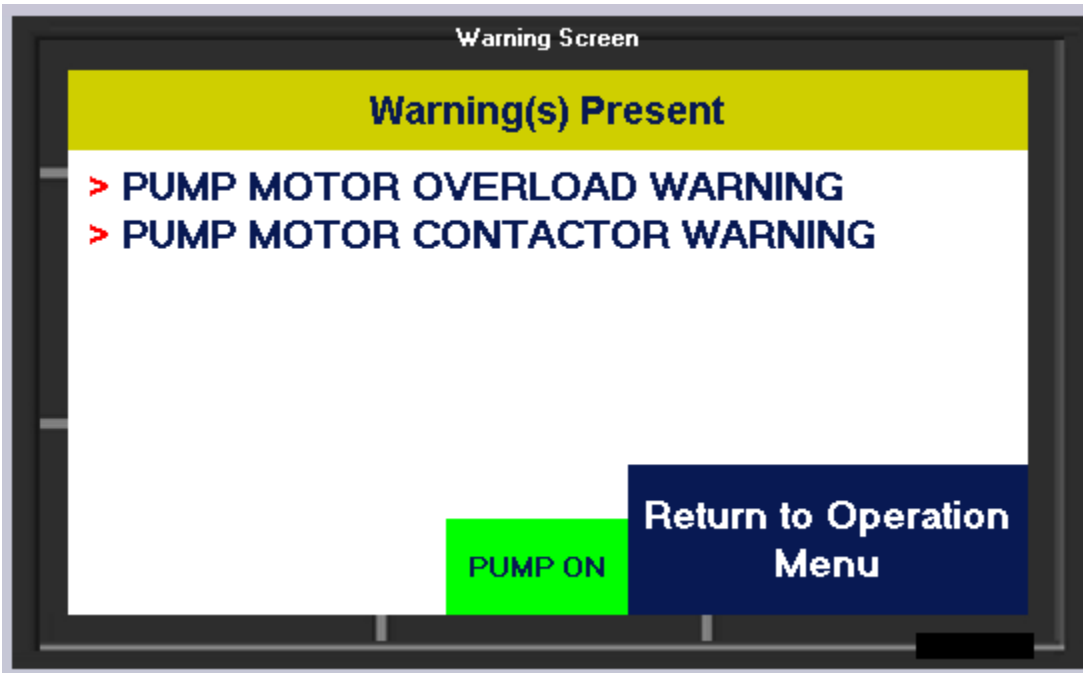

OPERATION MENU – PAGE 2 SCREEN

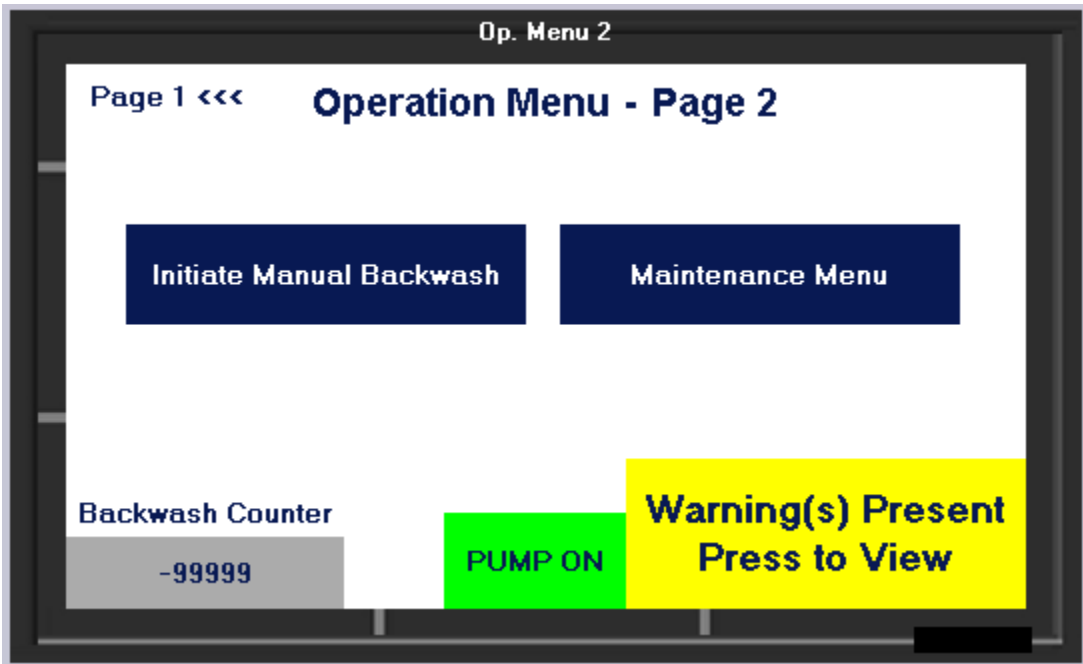

MANUAL BACKWASH CONFIRM SCREEN

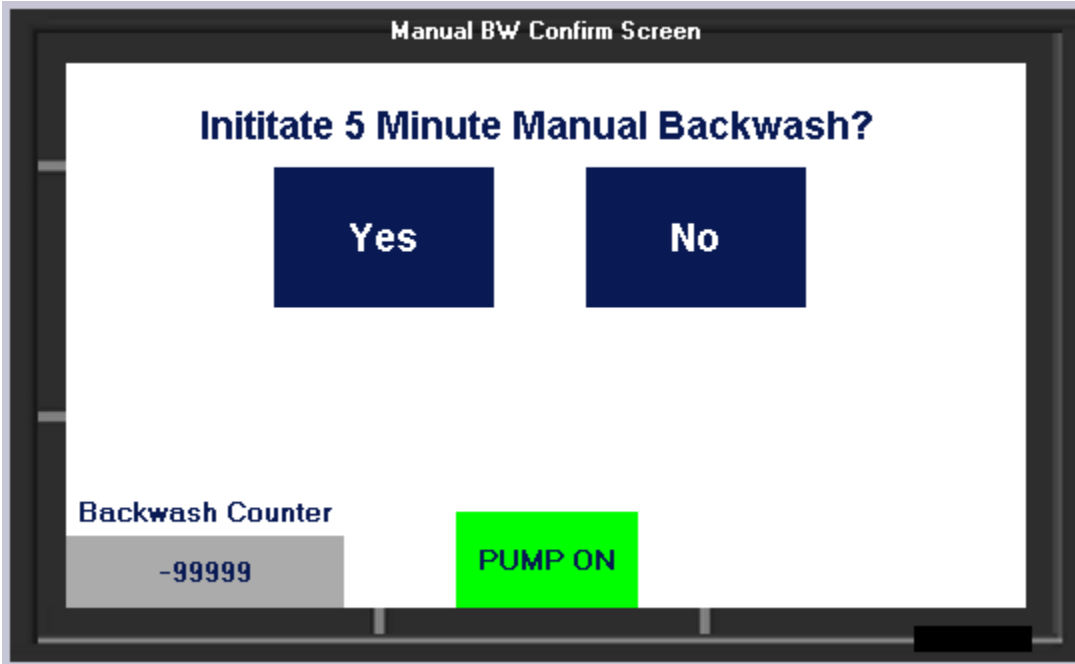

BACKWASH IN PROGRESS SCREEN



ABORT BACKWASH CONFIRM SCREEN



BACKWASH ABORTED SCREEN



BACKWASH COMPLETE SCREEN



MAINTENANCE MENU SCREEN

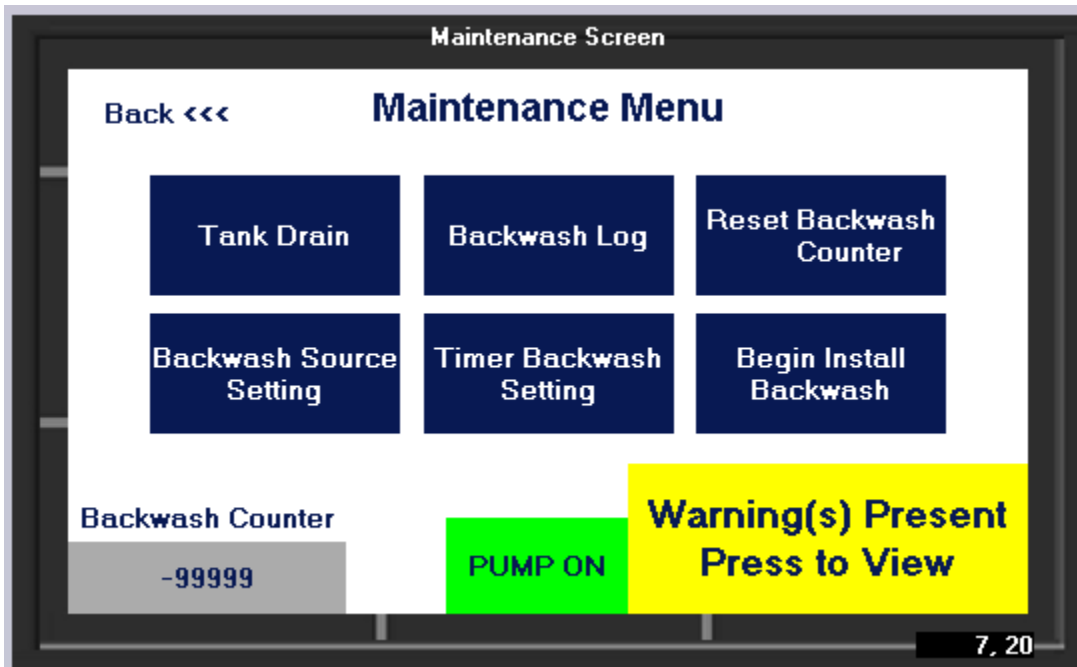

DRAIN SYSTEM CONFIRM SCREEN

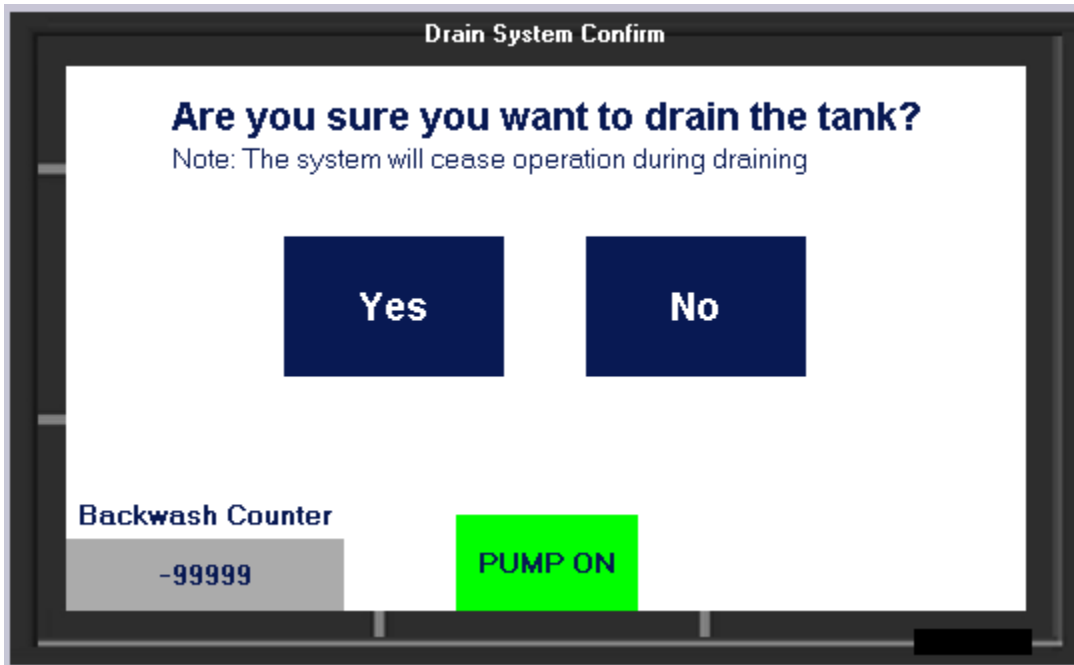

DRAIN SCREEN

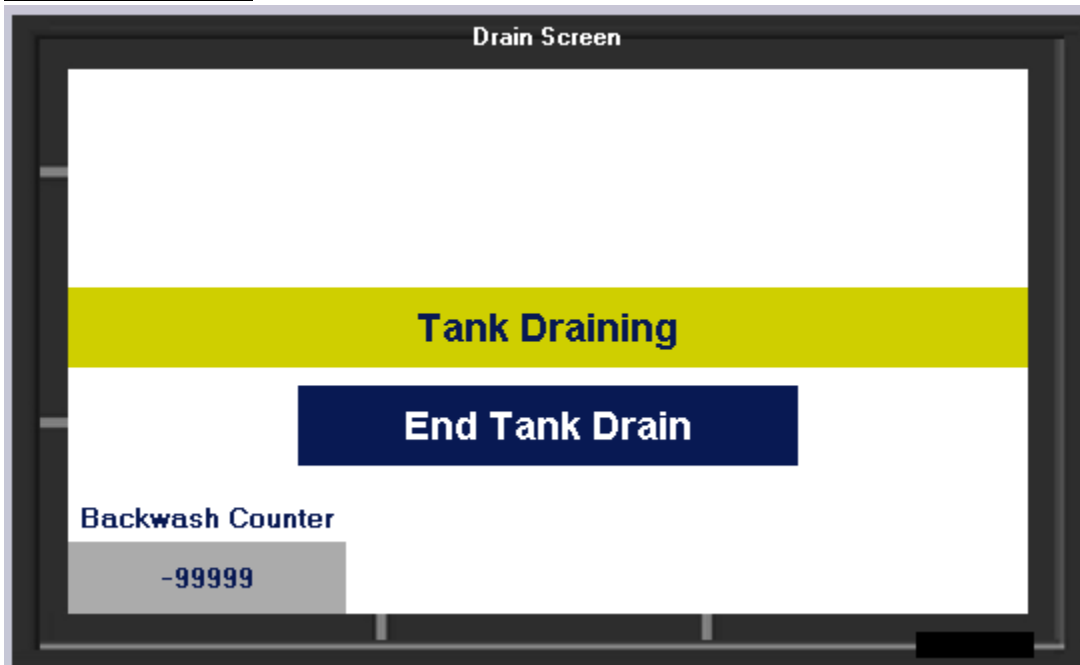

TANK DRAIN ENDED SCREEN

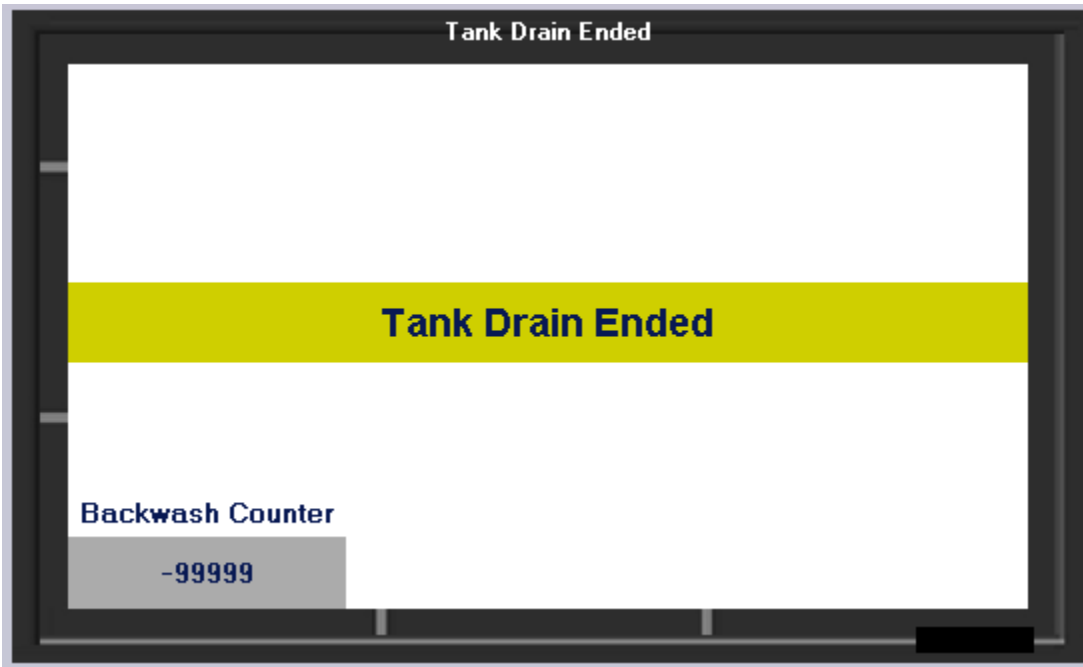

BACKWASH SOURCE SELECT SCREEN

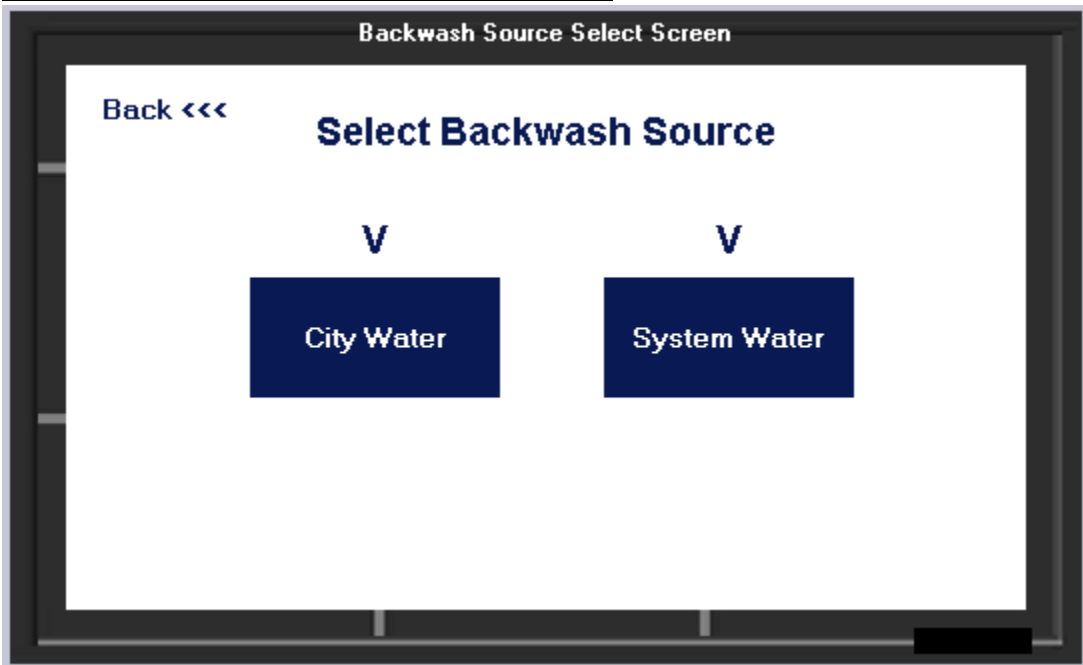

TIMER BACKWASH SETTING SCREEN

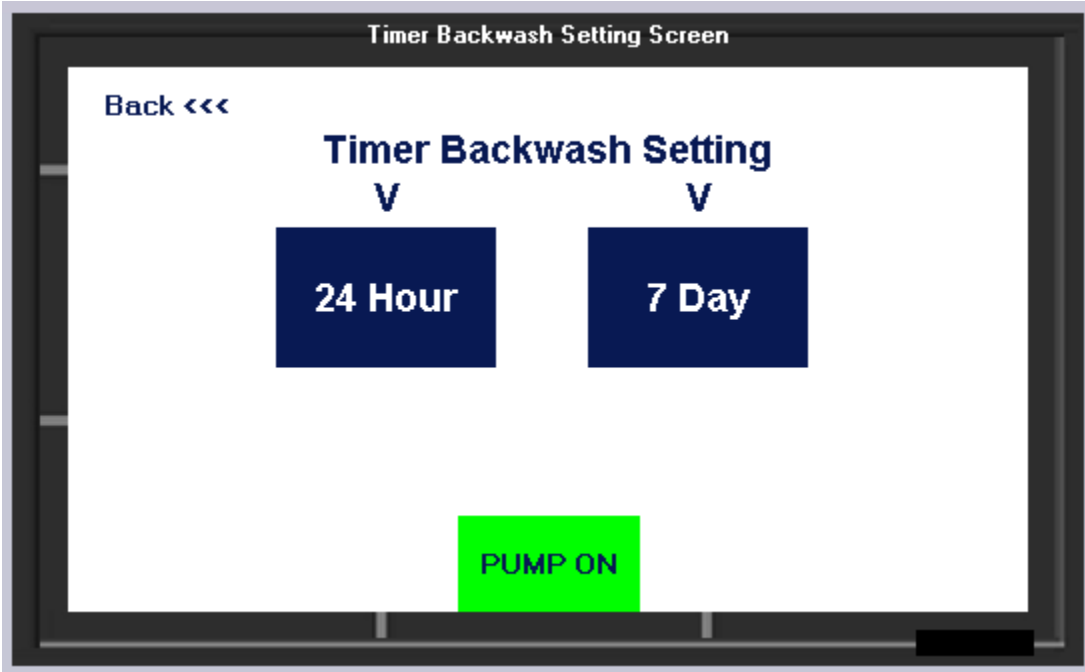

STARTUP BACKWASH CONFIRM SCREEN

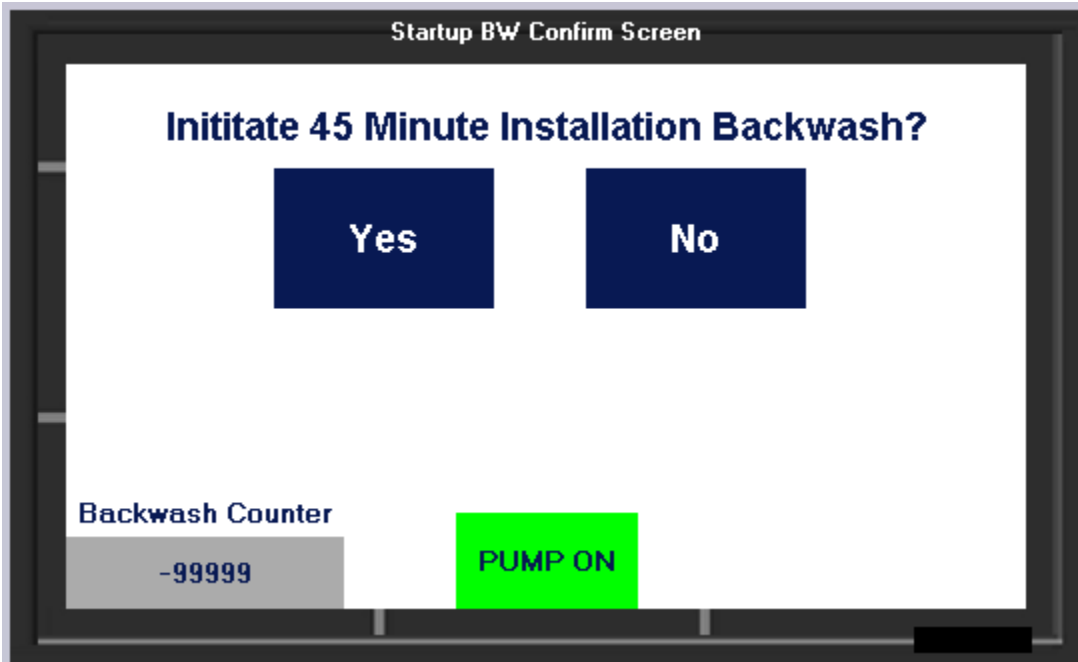

E-STOP SCREEN

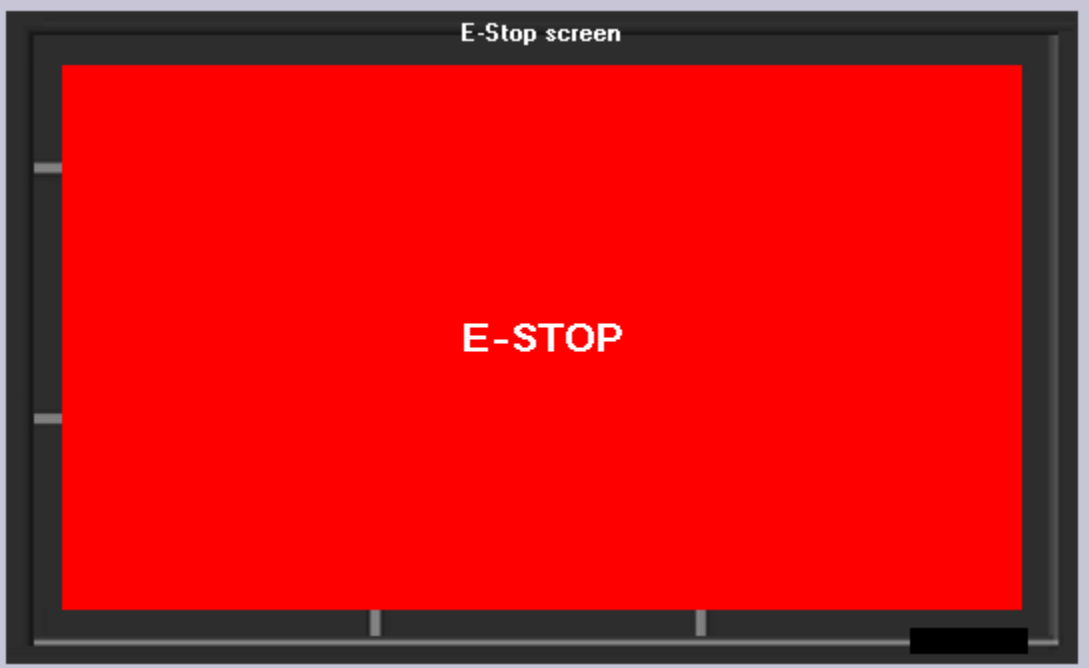

7 ALARMS

There are two warning conditions built into the CWFT: motor overload and motor contactor failure. When one or both of these warnings are present, a button on the bottom right hand corner of the HMI will appear that the user can press to view the Active Warnings.

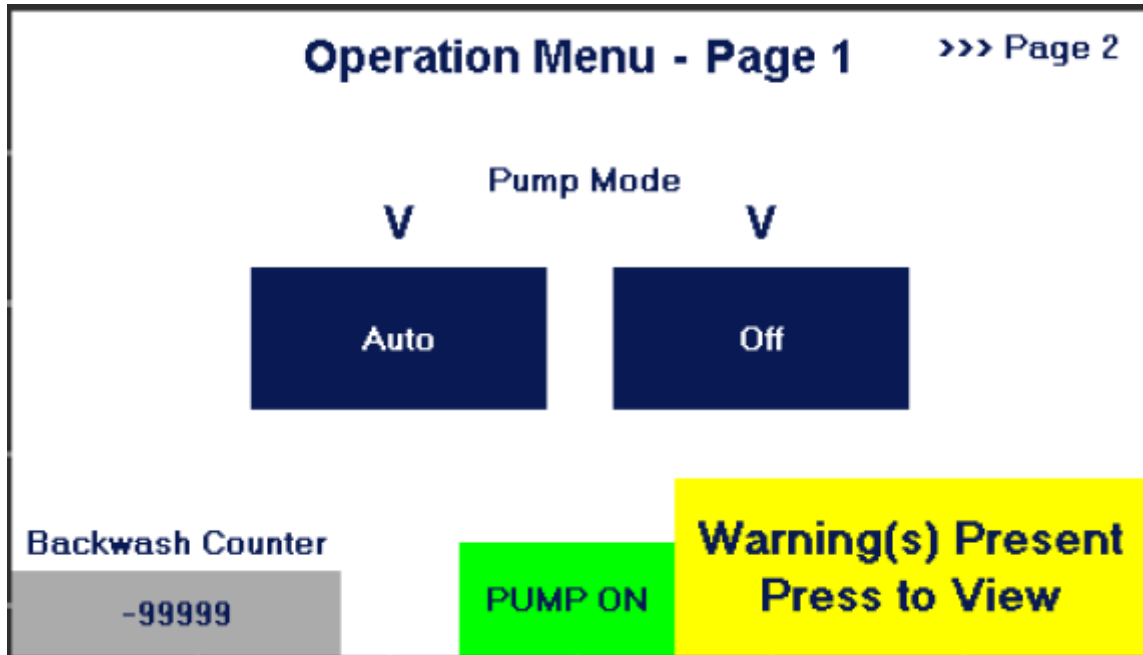

Upon pressing the Warning button, the Warning screen appears. Any warnings which are active will have a red arrow to the left of them on this screen. For example, The screen following would indicate that both a pump overload and motor contactor failure are active.

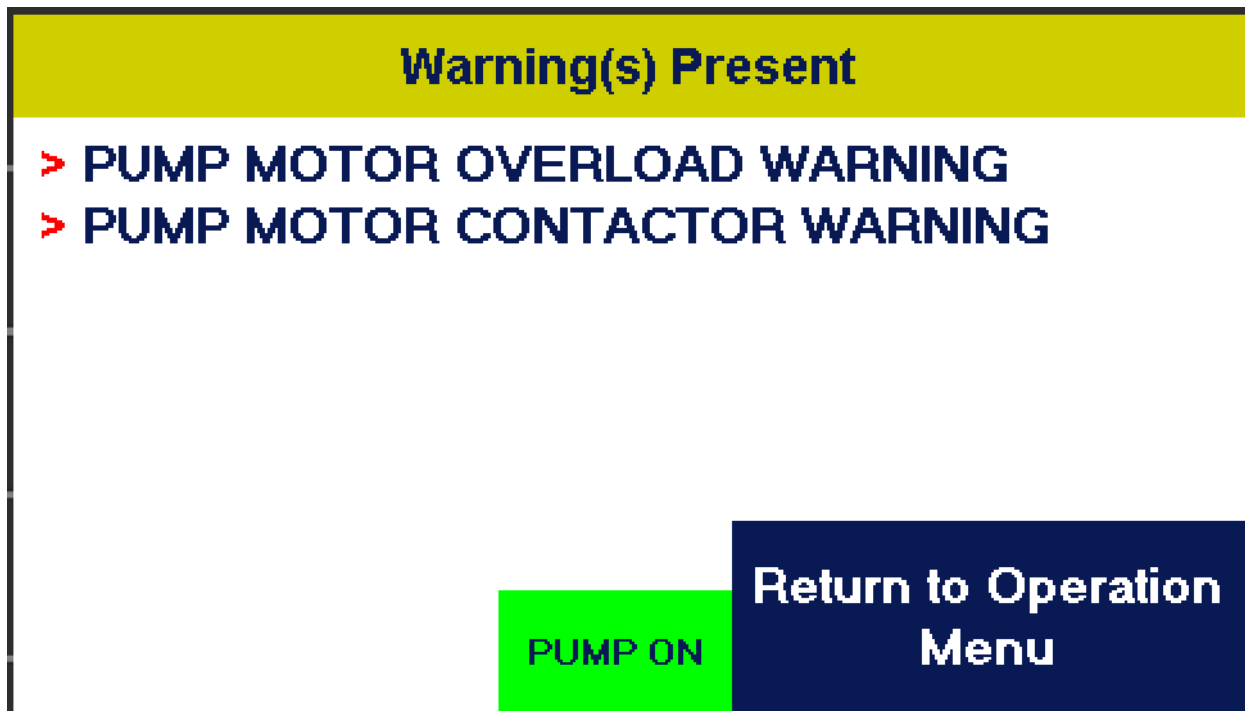

To return to the Operation Menu, simply press the Return to Operation Menu button. The warning indicator/button will remain in the bottom right hand corner of the screen until the warning conditions are cleared. Once they are cleared, the indicator/button will become invisible and inactive. If either of the two warning conditions are active, terminal block 21 will be energized.

8 COMPONENT INFORMATION AND SCHEMATICS

8.1 Component Identification

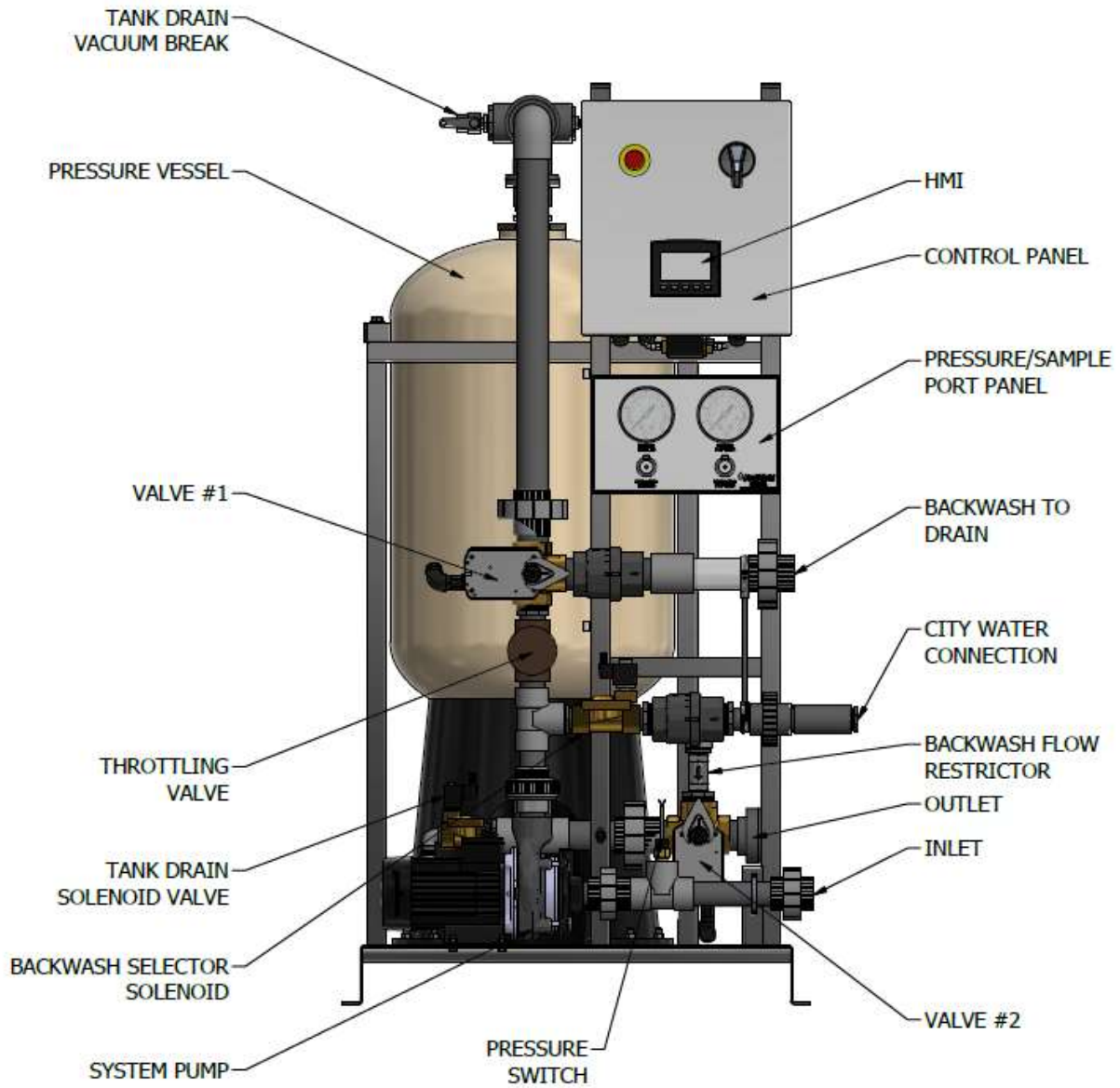

8.2 Electrical Schematic

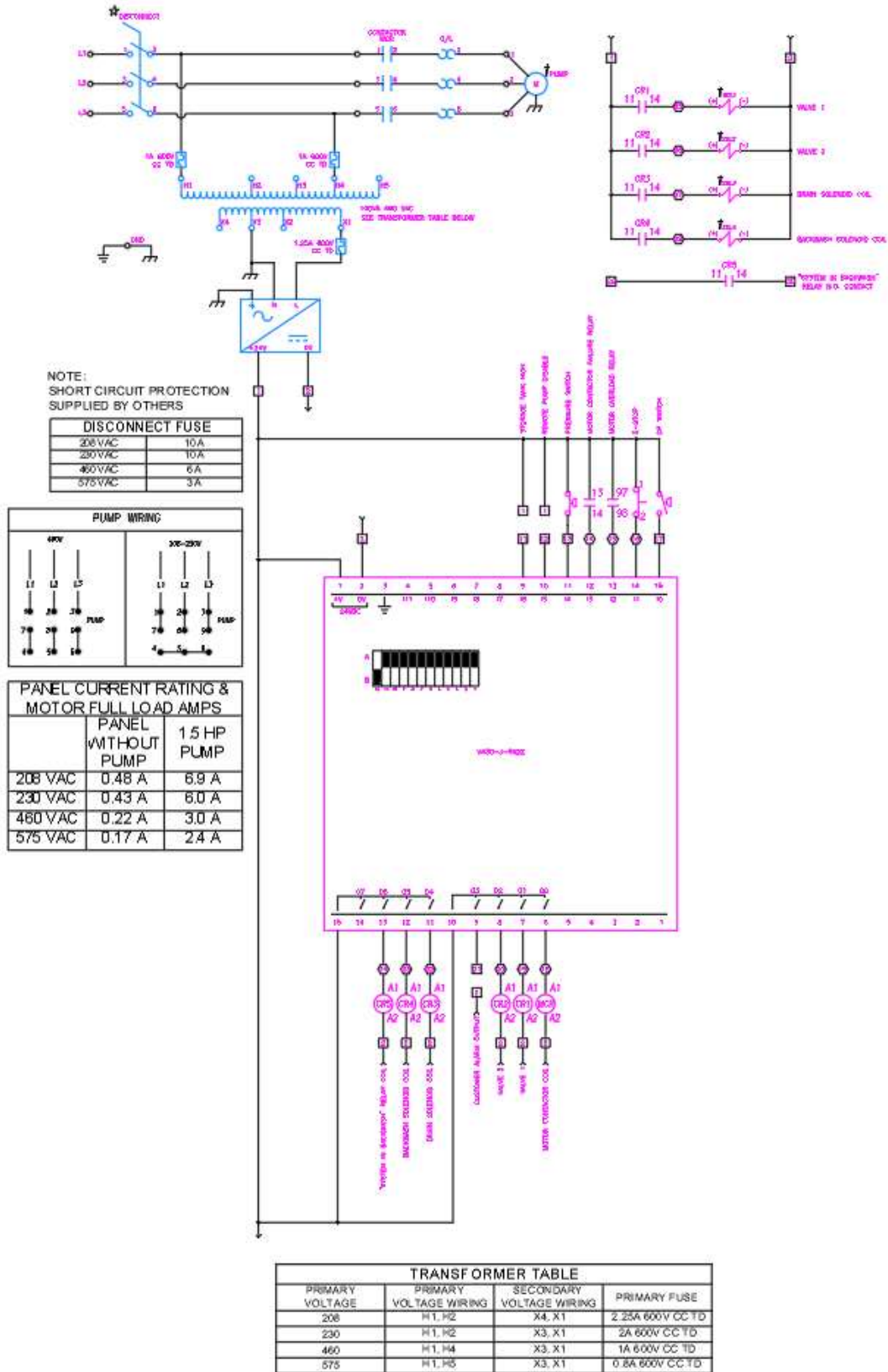

8.3 Flow Schematic

8.3.1 Mechanical Component Identification

Identifier	Description
P1	Filter Pump
P2	Globe Throttling Valve
P3	Electrically Actuated 3-Way Ball Valve - Valve #1
P4	Tank Drain Vacuum Break Check Valve
P5	Pre-Filter Pressure Gauge
P6	Pre-Filter Sample Port
P7	System Pressure Vessel
P8	Differential Pressure Switch
P9	Post-Filter Sample Port
P10	Post-Filter Pressure Gauge
P11	Electrically Actuated 3-Way Ball Valve - Valve #2
P12	N.C. System Water Solenoid Valve
P13	Backwash Flow Restrictor
P14	N.C. Drain Solenoid Valve

8.3.2 Service

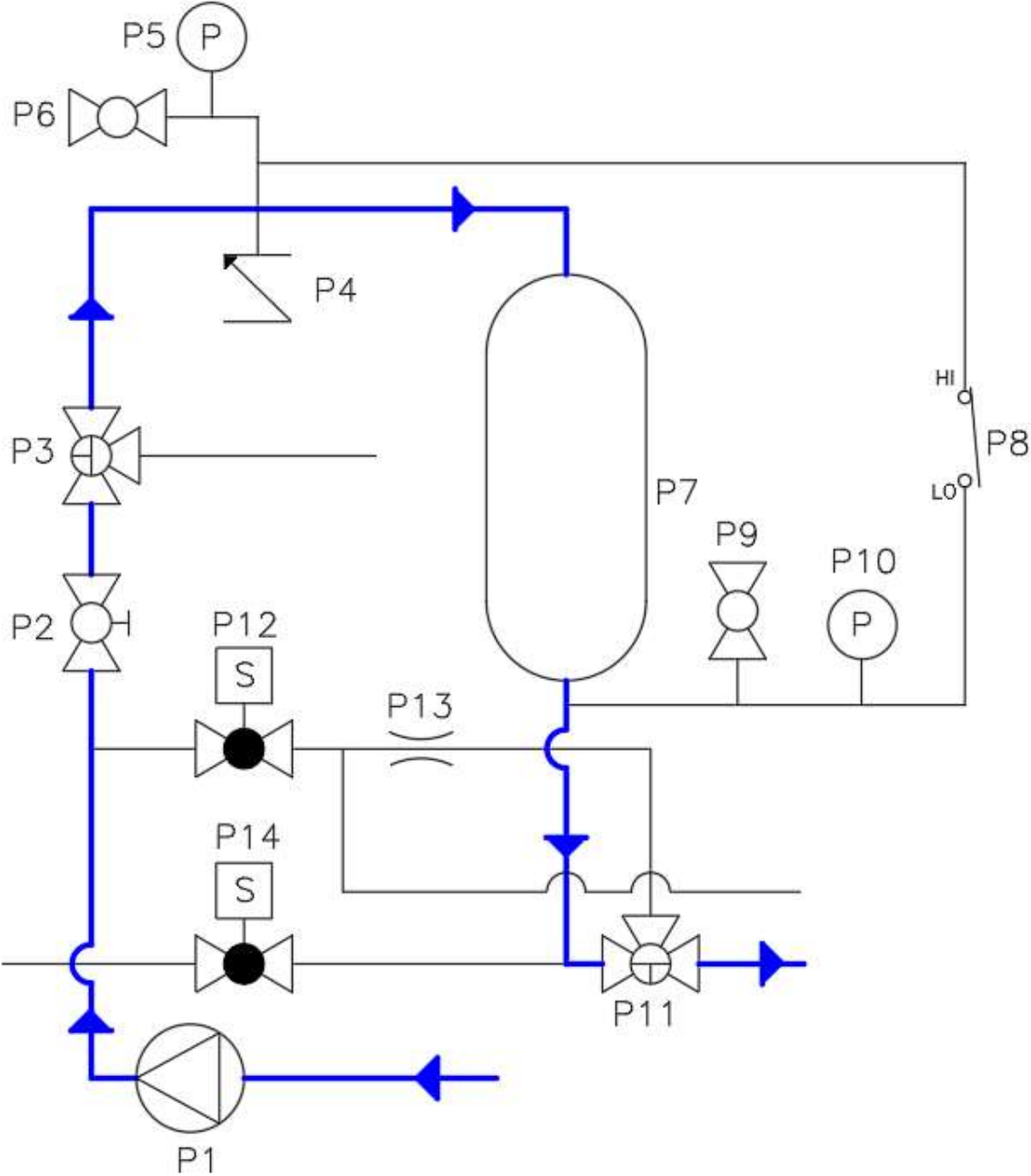

8.3.3 Backwash - City Water

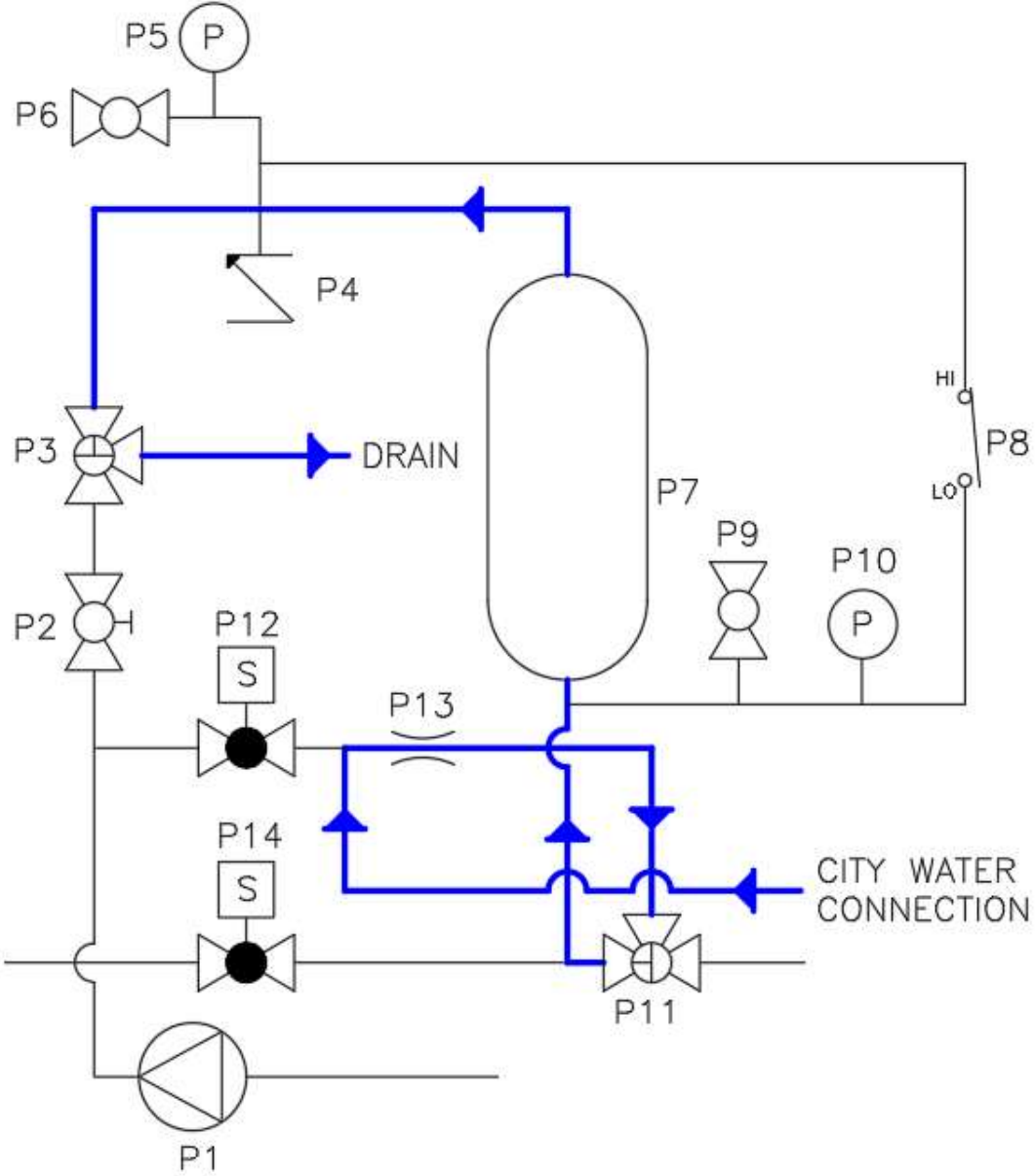

8.3.4 Backwash - System Water

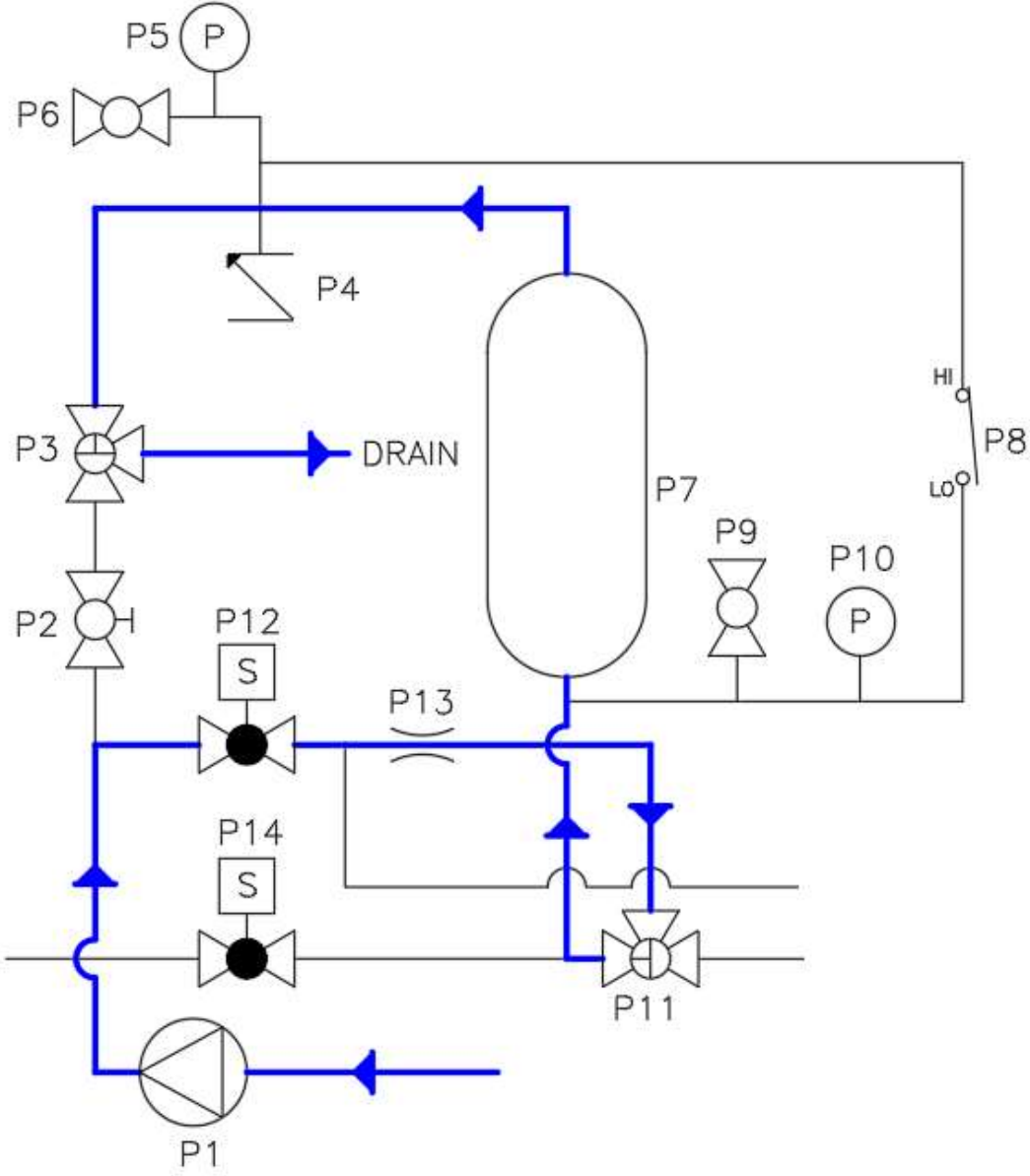

8.3.5 Drain

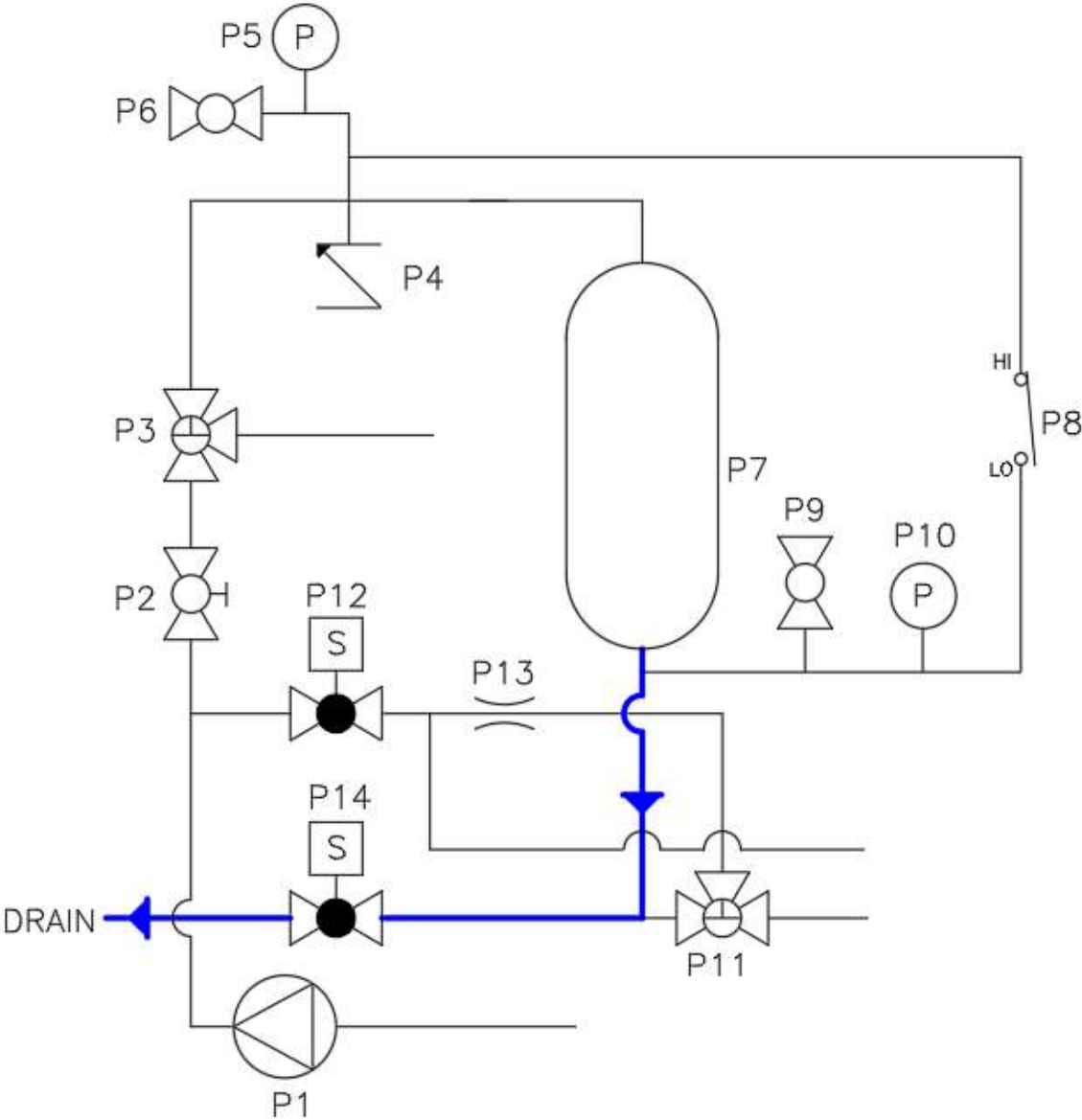

9 TROUBLESHOOTING

Refer to the Troubleshooting Guide below to aid in resolution of common questions.

Fault Condition	Possible Cause	What to Check
No filtration flow	Isolation valves closed	<ul style="list-style-type: none"> • Ensure pre-filter and post-filter isolation valves are open • Verify system is plumbed in per the Installation section of this product manual
	Throttling valve closed	<ul style="list-style-type: none"> • Verify that the CWFT system globe throttling valve is not closed all the way. Adjust this valve until the differential pressure across the media bed is 10 psi for a clean media bed ("clean" refers to a media bed which has just been backwashed) • Ensure throttling valve has no debris clogging the opening
	Valve #1 in wrong position	<ul style="list-style-type: none"> • Ensure that side A of the valve actuator is facing out • Verify that indicator is consistent with the position of the valve
	Valve #2 in wrong position	<ul style="list-style-type: none"> • Ensure that side A of the valve actuator is facing out • Verify that indicator is consistent with the position of the valve
Low filtration flowrate	Media bed compacted	<ul style="list-style-type: none"> • Perform a Manual backwash and return the filter to service. To prevent the media bed from becoming compacted after resetting it with a backwash, start the filter back into service with the throttling valve closed completely. Slowly open the throttling valve until there is a 10 psi differential pressure across the media bed
	Clogged basket strainer	<ul style="list-style-type: none"> • Ensure that the basket strainer mesh is not clogged on the inlet plumbing to the filter
	Throttling valve closed too far	<ul style="list-style-type: none"> • Ensure that the throttling valve is not closed too far. To close the throttling valve the proper amount, perform a backwash and when putting the filter back into service, start with the throttling valve closed completely. Slowly open the throttling valve until there is a 10 psi differential pressure across the media bed

Fault Condition	Possible Cause	What to Check
No backwash flow	Appropriate source not selected in HMI for plumbing	<ul style="list-style-type: none"> • Ensure that if City Water is desired for backwash supply that it is chosen as the source on the HMI and that there is city water plumbing connected to the unit • Ensure that if System Water is desired for backwash supply that it is selected as the source on the HMI and that the city water connection is plugged
	Valve #1 in wrong position	<ul style="list-style-type: none"> • Ensure that side A of the valve actuator is facing out • Verify that indicator is consistent with the position of the valve
	Valve #2 in wrong position	<ul style="list-style-type: none"> • Ensure that side A of the valve actuator is facing out • Verify that indicator is consistent with the position of the valve
	Backwash solenoid valve malfunction	<ul style="list-style-type: none"> • Ensure that the backwash solenoid valve DIN connector is secured to the pins on the valve with the DIN connector screw • Ensure that the signal coming to the valve is 24VDC by using a multi-meter and measuring the voltage difference between terminal block 23 and neutral (terminal blocks 27-34) • Verify there are no debris stuck in the solenoid valve body that are keeping the plunger from opening
Low backwash flow	City water pressure not within specified pressure range	<ul style="list-style-type: none"> • If using city water as the backwash source, ensure that the city water pressure is between 40-70 psi at the connection to the CWFT city water connection (after the backflow preventer)
	Pressure switch malfunction	<ul style="list-style-type: none"> • If using System Water as the backwash source, ensure that the pressure switch is closed at pressures less than 40 psi and opened for pressures greater than 40 psi. In order to test this, perform a continuity test to check for a closed circuit in closed state and open circuit in open state
	City water strainer clogged	<ul style="list-style-type: none"> • If using city water as the backwash source, ensure that the strainer is not clogged on the inlet to the city water connection to the filter

Fault Condition	Possible Cause	What to Check
Tank not draining	Drain solenoid valve malfunction	<ul style="list-style-type: none"> • Ensure that the drain solenoid valve DIN connector is secured to the pins on the valve with the DIN connector screw • Ensure that the signal coming to the valve is 24VDC by using a multi-meter and measuring the voltage difference between terminal block 22 and neutral (terminal blocks 27-34) • Verify there are no debris stuck in the solenoid valve body that are keeping the plunger from opening
High differential pressure in service immediately after backwash	Insufficient backwash flow	<ul style="list-style-type: none"> • Check to ensure that there is sufficient backwash flow through the filter during backwash. See portion of troubleshooting guide related to this fault condition above
	Media bed compacted	<ul style="list-style-type: none"> • Media bed may have been compacted due to the throttling valve being left open too far. Run a Manual backwash and while this is running close the throttling valve completely. Once the filter is returned to Service, slowly open the throttling valve until there is a differential pressure of ~10 psi across the media bed
Excessive media backwashed to drain	City water pressure too high	<ul style="list-style-type: none"> • Check to ensure that the city water pressure is between 40-70 psi after the backflow preventer
	Loop pressure too high	<ul style="list-style-type: none"> • Verify that the inlet to the system (loop pressure) is no greater than the maximum inlet pressure of the filter of 60 psi
	Air in bottom of pressure vessel	<ul style="list-style-type: none"> • Open the outlet sample port valve to check and see if any air is being vented. If there is air at the bottom of the tank, simply vent using the outlet sample port valve and close once a continuous stream of water begins to flow
	Flow restrictor orifice missing	<ul style="list-style-type: none"> • Ensure that the flow restrictor has the rubber orifice within the body. If this is missing the restrictor will not behave as intended
Frequent backwashing	System cross plumbed	<ul style="list-style-type: none"> • Ensure that the points on the loop where the filter is plumbed (the taps to and from the filter) are at the same pressure. If the filter is

Fault Condition	Possible Cause	What to Check
		<p>plumbed with the outlet at a much lower pressure than the inlet, the unit will frequently backwash</p> <p>NOTE: It is typical for a newly installed unit to backwash frequently due to the high number of suspended solids that exist in a cooling tower loop that hasn't been filtered</p>
	Throttling Valve open too far	<ul style="list-style-type: none"> • Check to make sure the throttling valve is not open too far. To open the throttling valve the proper amount, perform a manual backwash and while this is running close the throttling valve completely. Once the filter is returned to Service, slowly open the throttling valve until there is a differential pressure of ~10 psi across the media bed
	Media dusty	<ul style="list-style-type: none"> • If the system has recently been installed and an Installation Backwash was not performed, the media will still contain a significant amount of dust and cause a high differential pressure across the bed in Service. If you are unsure if an Installation Backwash has been performed, perform an installation backwash and then put the unit into Service
Pump will not run	Motor overload is tripped	<ul style="list-style-type: none"> • Examine the HMI to see if the Warning(s) Present indicator is visible and, if so, if the motor overload warning is present • If there is a motor overload condition, check to see that the incoming 3-phase voltage to the panel is within $\pm 10\%$ of the rated system voltage
	Motor contactor error	<ul style="list-style-type: none"> • Examine the HMI to see if the Warning(s) Present indicator is visible and, if so, if the motor contactor warning is present • If there is a motor contactor warning, ensure that the voltage difference between terminal block 18 and Neutral (terminal blocks 27-34) is 24VDC when the pump should be running (the "Pump

Fault Condition	Possible Cause	What to Check
		On" light should be visible on the HMI)
	Motor wired incorrectly	<ul style="list-style-type: none"> • Turn the local disconnect to the Off position and ensure that the pump is wired per the wiring diagram in Section 3.2 of this product manual for the appropriate voltage
3-way valves not fully opening or closing	Insufficient supply voltage	<ul style="list-style-type: none"> • Verify that the voltage between terminal blocks 19 (for valve 1) and Neutral (terminal blocks 27-34) and between terminal blocks 20 (for valve 2) and Neutral is 24 VDC
	Objects wedged in valve	<ul style="list-style-type: none"> • Verify that there are no debris wedged in the valve that are preventing the ball from rotating to a desired position

10 SPARE PARTS LISTING

10.1 Inlet Plumbing

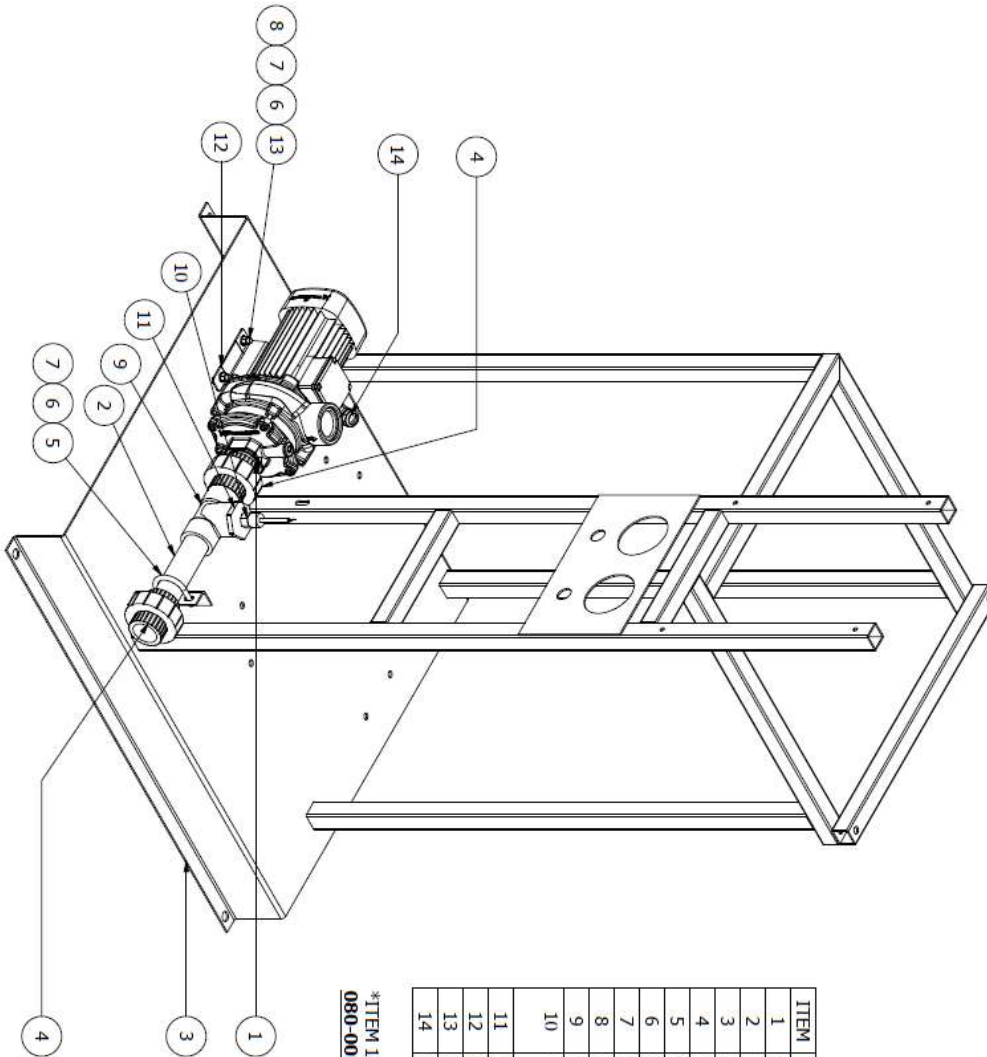

ITEM	PART NUMBER	DESCRIPTION
1	041730163	NIPPLE,1.5XCL,PVC80
2	021720141	PIPE,1.5,PVC80
3	090-0015	FRAME,FLOOR MOUNT,FORTI,STEEL
4	041-0051	UNION,1.5,SOCKTHRD,PVC80
5	92-0043	BOLT,U-SHAPED 1-1/2" PIPE
6	92730127	NUT,3/8-16,HEX,SS
7	93730123	WASHER LOCK 3/8IN.,SS
8	92-0041	WASHER,FLAT,.375,SS,HD
9	041720145	TEE,1.5,SOC,PVC80
10	068-0002	SWITCH,PRESSURE,40 PSI,NC,RISING,1/2"MNPT
11	041-0037	BUSH,2X.5,SOCKTHRD,PVC80
12	SEE NOTE*	PUMP,GRUNDFOS CM10-1.1.5 HP,3PH
13	92730235	BOLT,3/8-16X1,HEX HD,SS
14	66730199	CONNECTOR,CONDUIT .5,ELBOW

*ITEM 12 IS P/N **080-0014** FOR 208, 230, AND 460V SYSTEMS AND **080-0016** FOR 575V SYSTEMS

10.2 Pre-Filter Plumbing

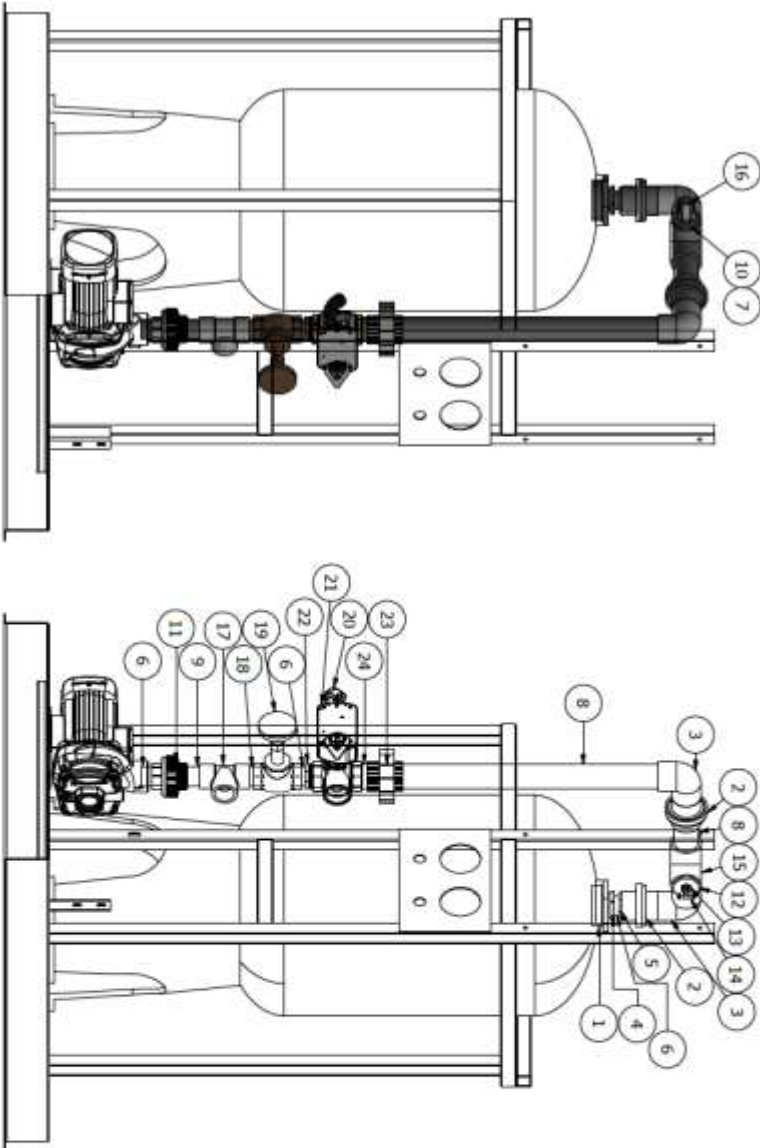

ITEM	PART NUMBER	DESCRIPTION
1	027-0002	BUSH, 4X2, THRD, UNION NPT, CPVC
2	041730387	UNION, 2, SOCC, PVC80
3	041720144	EL, 2, SOCC, PVC80
4	048-0011	BUSH, 2X1.5, THRD, DOUBLE TAP, STL, +NICKEL
5	041-0022	BUSH, 2X1.5, SOCC, THRD, PVC80
6	041730163	NIPPLE, 1, 5XCL, PVC80
7	041520207	BUSH, 1X, 5, THRD, PVC80
8	021720146	PIPE, 2, PVC80
9	021720141	PIPE, 1.5, PVC80
10	041730182	BUSH, 2X1, SOCC, THRD, PVC80
11	041-0051	UNION, 1, 5, SOCC, THRD, PVC80
12	041531866	BUSH, 2X, 5, SOCC, PVC80
13	041530223	BUSH, 5X, 2.5, SOCC, THRD, PVC80
14	10-L127	Swivel Branch Tee 0.25T X 0.25 NPT Male
15	041-0026	CROSS, 2, SOCC, PVC80
16	041720199	VAL, BALL, 5, MPT, EPF, PVC80, EPD M
17	041720145	TEE, 1.5, SOCC, PVC80
18	041-0088	NIPPLE, 1, 5X2.5, PVC80 (TIE NIP)
19	050-0432	VAL, GLOBE, 1.5", FNPT, BRONZE, 175 PSI
20	66730199	CONNECTOR, CONDUIT, 5, ELBOW VAL, BALL, ACTIVATED, SPRING
21	051-0023	RETURNS, 3WAY, 2", BRASS
22	041730167	BUSH, 2X1.5, THRD, PVC80
23	041760300	UNION, 2, SOCC, THRD, PVC80
24	041531942	NIPPLE, 2XCL, PVC80

NOTE:
CONTACT AMERIWATER FOR INFORMATION
REGARDING TANK INTERNALS

10.3 Post-Filter Plumbing

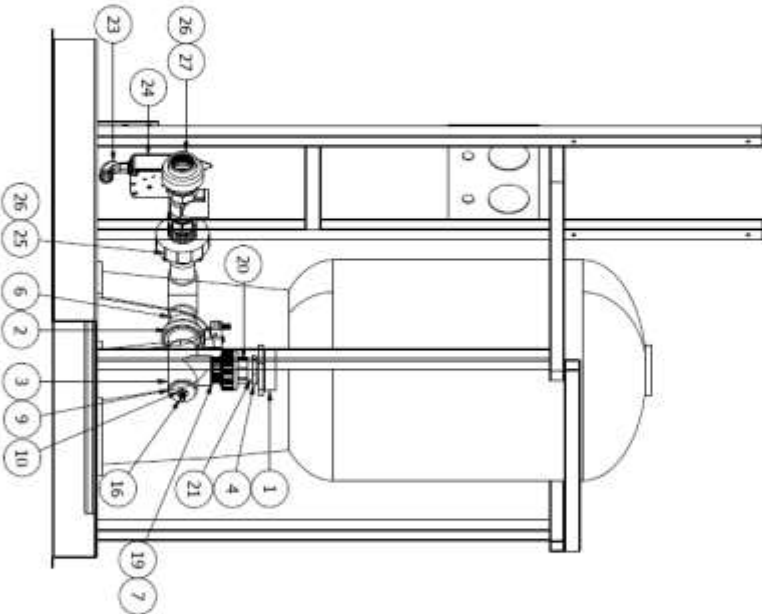
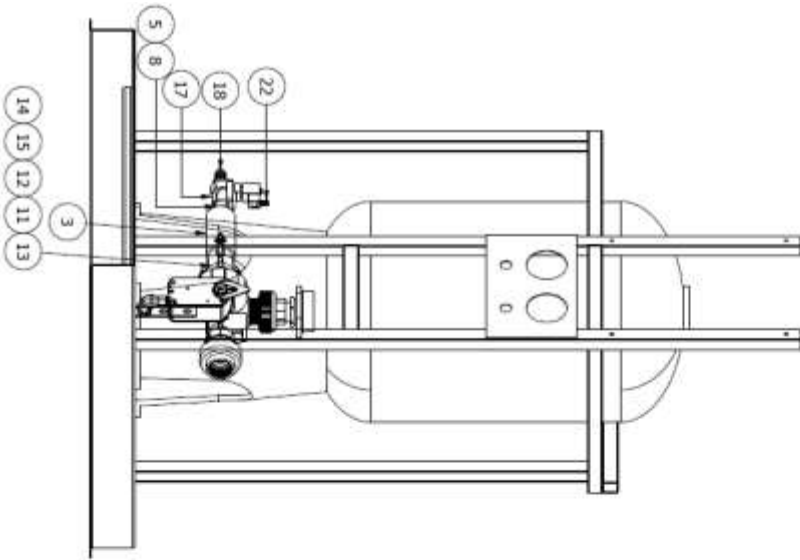

ITEM	PART NUMBER	DESCRIPTION
1	027-0002	BUSH, 4X2, THRD, UNKNPT, PVC
2	041730187	UNION, 2.50C, PVC80
3	041720119	TEE, 2.50C, PVC80
4	048-0011	BUSH, 2X1.5, THRD, DOUBLE TAP STL +NICKEL
5	041720151	NIPPLE, 1XCL, PVC80
6	021720146	PIPE, 2, PVC80
7	021720141	PIPE, 1.5, PVC80
8	041730182	BUSH, 2X1.50CXTHRD, PVC80
9	041531866	BUSH, 2x, 5, 50C, PVC80
10	041530223	BUSH, .5X, 25, 50CXTHRD, PVC80
11	92730127	NUT, 3/8-16, HEX, SS
12	93730123	WASHER LOCK, 3/8IN, SS
13	91-0028	CLAMP, SPLIT RING, GALVANIZED, 2 SCHEDULE 80 PIPE, 0.375 THREAD
14	92754222	STUD 3/8-16 THREADED ROD
15	92-0041	WASHER, FLAT, 3/8IN, SS, HD
16	10-4102	LEGRI'S SWIVEL EL, MALE, 0.25T X 0.25INPT
17	059-0005	VAL, SOL, 1", 24VDC, BRASS, NC
18	14560326	ADPT, 1INPT X 1IN, PVC80
19	041720142	BUSH, 2X1.5, 50C, PVC80
20	041720101	Union, 1.5 50C, PVC
21	041-0088	NIPPLE, 1.5X2.5, PVC80 (TIE NIP)
22	66932109	WIPE HAIRNESS, DIR, STD ISO, 6FT, STRIPPED ENDS
23	66730199	CORINNECTOR, CONDUIT 5, ELBOW
24	051-0023	VAL, BALL, ACTUATED, SPRING RETURN, 3WAY, 7", BRASS
25	041760300	NIPPLE, 2.50CXTHRD, PVC80
26	041531942	NIPPLE, 2XCL, PVC80
27	041-0294	UNION, 2, PPTXPT, PVC80

NOTE:
CONTACT AMERWATER FOR INFORMATION
REGARDING TANK INTERVALS

10.4 Backwash Plumbing

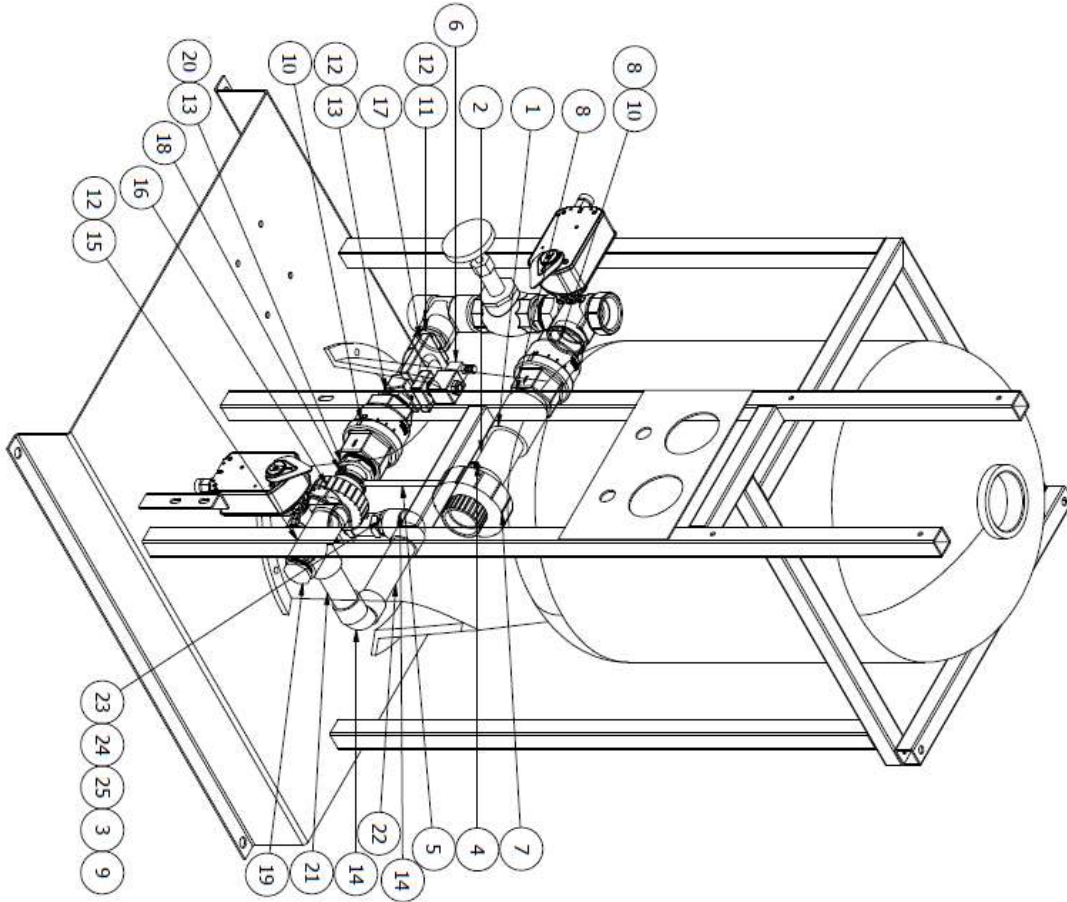

ITEM	PART NUMBER	DESCRIPTION
1	041-0043	COUPLG, 2" SOCKTHRD, PVC80
2	041-0042	PIPE, 2" EXCELON
3	041720151	NIPPLE, 1XCL, PVC80
4	91-0028	CLAMP, SPLIT RING, GALVANIZED, 2 SCHEDULE 80 PIPE, 0.375 THREAD
5	92754222	STUD 3/8-16 THREADED ROD
6	66932109	WIRE HARNESS, DIN, STD ISO, 6FT, STRIPPED ENDS
7	041760300	UNION, 2.50CXTHRD, PVC80
8	041531942	NIPPLE, 2XCL, PVC80
9	041-0217	BUSH, 2X1, THRD, PVC80
10	055-0008	VAL, CHECK, SPRING, 2" FNPT, 0.5 PSI SPRING
11	041720211	BUSH, 1.5X1.25, SOCKTHRD, PVC80
12	041530311	NIPPLE, 1.25XCL, PVC80
13	041720854	BUSH, 2X1.25, THRD, PVC80
14	041720243	EL, 1.25, SOC, PVC80
15	041730015	TEE, 1.25, THRD, PVC80
16	041730016	UNION, 1.25, SOCKTHRD, PVC80
17	059-0006	VAL, SOL, 1.25" FNPT, 24VDC, BRASS
18	91-0024	CLAMP, SPLIT RING, GALVANIZED, 1.25 SCHEDULE 80 PIPE, 0.375 THREAD
19	141-0018	PLUG, 1.25, MNPT, PVC80
20	041-0144	NIPPLE, 1.25X5, PVC80 (T/OE NIP)
21	041531004	NIPPLE, 1.25X8, PVC80
22	021670125	PIPE, 1.25, PVC80
23	041720855	BUSH, 1.25X1, SOC, PVC80
24	41730348	NIPPLE, 1X6, PVC80
25	SEE NOTE*	FLOW CONTROL, SST, 1" FPT X 1" FPT

*ITEM 25 IS P/N **42-0025** FOR 0.5 MICRON SYSTEMS AND **50-0136** FOR 2 MICRON SYSTEMS

10.5 Miscellaneous

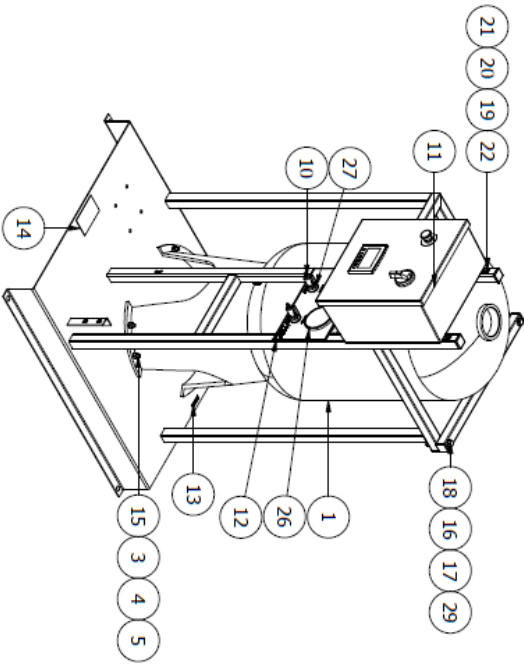
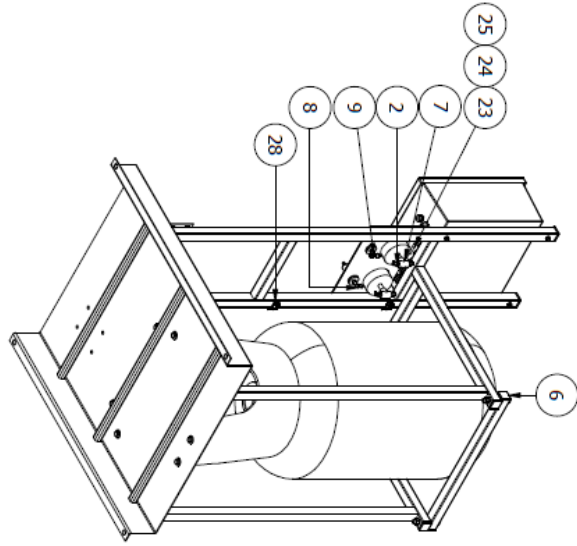

ITEM	PART NUMBER	DESCRIPTION
1	026-0004	TANK, POLYGLASS, 21X36, 4" TOP/BOTTOM, TRIPPOD BASE
2	10-L002	LEGRIIS MALE CON, 0.25T X 0.25MPT
3	092-0006	NUT, 7/16"-14, HEX, ZINC PLATED
4	092-0008	WASHER, FLAT, 7/16" ZINC PLATED
5	092-0007	WASHER, LOCK, 7/16" ZINC PLATED
6	090-0016	CAP, 1.5" SQUARE TUBE, LDPE
7	141-0011	TEE, 0.25", THRD, PVC80
8	10-L102	LEGRIIS SWIVEL EL, MALE, 0.25T X 0.25MPT
9	10-L127	Swivel Branch Tee 0.25T X 0.25 NPT Male
10	051-0021	VAL, BALL, 1/4" MNPT X 1/4" HB, PP
11	001-053-0007	CONTROL ASSY, FORTI
12	099-0013	LABEL, FORTI, PRIMARY
13	099-0004	LABEL, LIFT HERE, 2.00" X 0.5"
14	099-0015	LABEL, "DO NOT LIFT THIS END", 3X5"
15	092-0014	BOLT, 7/16"-14 X 1.5 " LING, ZINC PLATED
16	92730117	NUT, 1/2-13, HEX, SS
17	92-0069	WASHER, FLAT, 1/2IN., SS, 1-1/16OD
18	92-0085	BOLT, 1/2-13 X 4, HEX HD, SS
19	92531207	NUT, 5/16-18 SST
20	92531904	WASHER, 5/16 FLAT SS
21	92531907	WASHER, 5/16 LOCK SS
22	92-0023	BOLT, 5/16-18 X 2.25 HEX HEAD SS
23	68-0002	SWITCH, HEF, DIFFERENTIAL, ADJUSTABLE, AL, SET TO 18PSI, (BRASS)
24	092-0015	WASHER, FLAT, 1/4", NEOPRENE
25	92730107	BOLT, 1/4-20 X 1/2" LG, HEX HD S/S
26	043-0157	GALUGE, 0-160, .25 MNPT, CBM, 4", LF, SS/BR
27	041-0074	BULKHD, .25FPT, PVC80, VITON
28	066-0023	CABLE HOLDER, UP TO 3/8" OD, ADHESIVE BACK
29	92730123	WASHER, LOCK 1/2IN. SS
30	SEE NOTE*	FILTRATION MEDIA

*ITEM 30 IS P/N **001-036-0002** FOR 0.5 MICRON SYSTEMS AND **001-036-0001** FOR 2 MICRON SYSTEMS

11 APPENDIX

11.1 Warranty Information

This product is covered under the standard AmeriWater warranty policy. For specific terms and conditions, please contact your AmeriWater Sales Representative.

HEF unit is intended to be used within all manufacturer's recommended specifications. Refer to specific part manufacturer to verify any compatibility questions or ratings. Improper use of the equipment will void the Warranties.

 **WARNING**

This product can expose you to chemicals such as vinyl chloride (used in the production of PVC) or Nickel (used in the production of stainless steel), that are known to the State of California to cause cancer. For more information go to www.P65Warnings.ca.gov.

Dear Valued Customer,

California Proposition 65 (Prop 65) is the Safe Water and Toxic Enforcement Act of 1986. The State of California began enforcing amendments to California Prop 65 at the end of August 2018. Prop 65 requires manufacturers to provide a clear and reasonable warning to residents of California about chemicals used in products that they purchase that are included on the Prop 65 Chemical List. The chemicals included on the list are chemicals that are known to the State of California to cause cancer, birth defects, or other reproductive harm. One such chemical is Vinyl Chloride, a compound used to produce Polyvinyl Chloride (PVC). The AmeriWater system you have purchased may contain PVC or stainless steel parts.

While warnings are only required in the State of California, AmeriWater has initiated the use of Prop 65 labeling for all products to ensure compliance with California regulations. Please note that the above warning does not necessarily mean that the product that you have purchased is unsafe. Products that have been cleared for market by FDA have been determined to be safe and effective by the United States Food and Drug Administration. The warning is simply a requirement by the State of California. If you wish to obtain additional information, please visit: p65warnings.ca.gov. You may also contact your AmeriWater representative if you have any questions.

Thank you for your understanding and we look forward to continuing to serve you.