



# MROX

**OPERATION & MAINTENANCE MANUAL  
FOR MODELS  
MRO2X, MRO3X, MRO4X AND MRO5X  
FOR CENTRAL SYSTEM APPLICATIONS**



**Manufactured With Pride  
In The USA**

www.amerewater.com • 800-535-5585

AmeriWater • 3345 Stop 8 Road • Dayton, OH 45414

PN 98-0058  
Rev. R



## CAUTIONARY SYMBOLS



Caution, risk of electrical shock!  
**Attention, risque de choc électrique!**

Open by qualified service personnel only!  
**Ouverture par le personnel qualifié seulement!**

Refer to this Operation and Maintenance Manual for instructions and safety considerations.

**Référez-vous au manuel des Opérations et Entretien pour instructions et mesures de sécurité.**



Caution, risk of danger!  
**Attention, danger potentiel!**

For service by qualified service personnel only!  
**Entretien par le personnel qualifié seulement!**

Replace only with 120Vac, 15amp, time-delay fuse.  
**Remplacer avec 120Vac, 15 amp, fusible à retardement seulement.**



Earth Ground terminal  
**Borne de mise à la terre**



Product marked with this symbol indicates that it is protected throughout by double insulation or reinforced insulation.



This product has been tested to the requirements of CAN/CSA-C22.2 No. 61010-1, second edition, including Amendment 1, or a later version of the same standard incorporating the same level of testing requirements.

# TABLE OF CONTENTS

<b>SECTION 1, GENERAL INFORMATION .....</b>	<b>1</b>
1.1 INTRODUCTION .....	1
1.2 RESTRICTION ON USE .....	1
<b>SECTION 2, TECHNICAL INFORMATION .....</b>	<b>2</b>
2.1 SPECIFICATIONS.....	2
2.2 POWER RATINGS .....	3
2.3 MRO OUTPUT WATER QUALITY.....	3
2.4 TEMPERATURE CORRECTED MRO PRODUCTION RATES.....	4
2.5 ENVIRONMENTAL/TRANSPORT CONDITIONS EXPECTED .....	4
<b>SECTION 3, COMPONENTS AND SCHEMATICS .....</b>	<b>5</b>
3.1 EXTERNAL FRONT VIEW.....	5
3.2 INTERNAL REAR VIEW.....	7
3.3 ELECTRICAL DIAGRAM, MRO2X, MRO3X, MRO4X & MRO5X.....	9
3.4 FLUID DIAGRAM, MRO2X, MRO3X & MRO4X .....	10
3.5 FLUID DIAGRAM MRO5X .....	11
<b>SECTION 4, MRO STARTUP &amp; OPERATION.....</b>	<b>12</b>
4.1 CAUTION.....	12
4.2 SAFETY FEATURES.....	14
4.3 INITIAL STARTUP.....	15
4.4 SYSTEM SHUTDOWN .....	17
<b>SECTION 5, DISINFECTING THE SYSTEM.....</b>	<b>18</b>
5.1 DISINFECTING THE SYSTEM .....	18
5.2 DISINFECTING AN MRO AND “LARGE” LOOP SYSTEM.....	23
5.3 A WORD ABOUT HYDROGEN PEROXIDE/PEROXYACETIC ACID .....	24
5.4 MEMBRANE FLUSH FEATURE (AUTO FLUSH).....	25
<b>SECTION 6, MRO CONTROLLER .....</b>	<b>26</b>
6.1 FRONT PANEL CONTROLS AND INDICATORS .....	26
6.2 CONTROLLER OPERATION .....	27
6.3 CONTROLLER ADJUSTMENTS.....	30
6.4 STANDARD SETPOINTS .....	33
6.5 TO DISPLAY OR CHANGE SETPOINTS.....	35
<b>SECTION 7, EXTERNAL WIRE INSTALLATION .....</b>	<b>36</b>
<b>SECTION 8, MAINTENANCE .....</b>	<b>37</b>
8.1 MAINTAINING THE SYSTEM .....	37
8.2 PT401 ANTI-SCALANT .....	38
8.3 MEMBRANE MAINTENANCE INSTRUCTIONS.....	38
<b>SECTION 9, TROUBLESHOOTING AND REPAIR .....</b>	<b>40</b>
9.1 TROUBLESHOOTING CHART .....	40
9.2 CONTROLLER TROUBLESHOOTING .....	43
9.3 PUMP REPAIR .....	45
9.4 INSTALLING A REPLACEMENT PUMP ASSEMBLY .....	45
9.5 SOLENOID TEST PROCEDURE .....	46
9.6 SOLENOID VALVE REPLACEMENT .....	47
<b>SECTION 10, WARRANTY.....</b>	<b>47</b>
<b>SECTION 11 SPARE PARTS LISTING .....</b>	<b>48</b>
ROUTINE REPLACEMENT ITEMS (NON-DURABLE COMPONENTS) .....	50

# SECTION 1, GENERAL INFORMATION

## 1.1 INTRODUCTION

Congratulations on your decision to use the MRO system! The MRO is a water treatment system for use in hemodialysis applications. It is designed to pretreat and purify water resulting in product water that meets or exceeds ANSI/AAMI RD62 requirements for use in making dialysate for hemodialysis.

All models of the MRO are shipped completely assembled with required and optional water treatment components. The model that you purchased was selected for the volume of water needed and the analysis of your input water. This Operation Manual was written for the MRO2X, MRO3X, MRO4X, and MRO5X models.

Your MRO system was thoroughly tested and in excellent condition when it was shipped to you. However, because damage during shipment is possible, please unpack and carefully inspect the MRO as soon as you receive it. Please notify AmeriWater® if any problems are encountered.

The initials “PAA” are used occasionally throughout this manual to generically represent the hydrogen peroxide/ peroxyacetic acid solution that is to be used for disinfection. Peracidin® is an example of this solution. The caution on the front panel of the MRO that states “Use only PAA/Use no substitutes” means that any of these products are acceptable. Do not attempt to use anything other than hydrogen peroxide/ peroxyacetic acid disinfecting solution.

**Please read the Operations Manual before using the system.** Contact AmeriWater Customer Service with any questions at 1-800-535-5585 Monday through Friday 8:00 a.m. to 5:00 p.m. eastern standard time. For after hours emergencies call 1-800-535-5585 and follow the instructions on the recorded message. Our on-call technician will return your call as soon as possible.

**NOTE: This entire Operations Manual should be read before operating or servicing the system. This Operations Manual should then be kept near the system and used as a reference and troubleshooting guide.**

**WARNING:** This Reverse Osmosis System (RO) contains a preservative solution to prevent microbiological growth and freezing. Discard all product water for at least two hours of operation before placing the RO in service.

**CAUTION:** No person should attempt to operate or service the AmeriWater MRO without prior authorization, instruction, and training from AmeriWater and/or your medical facility director.

## 1.2 RESTRICTION ON USE

Federal law restricts this device for sale by or on the order of a physician (medical director) for use as a water treatment device for hemodialysis.

# SECTION 2, TECHNICAL INFORMATION

## 2.1 SPECIFICATIONS

Ideal, minimum, and maximum incoming water temperature	Min = 41° F (5° C)      Max = 90° F (33° C) Ideal Temperature = 77° F (25° C)
Prefilter gauge pressure (when the MRO is running) Minimum Maximum	20 PSI 90 PSI (Pounds per Square Inch)
Pump pressure – Minimum Maximum	150 PSI 275 PSI
Water pressure to dialysis machine	Controlled by Loop return relief valve.
Maximum output of product water @ 77°F (25°C), TDS<1000 ppm of NaCl, & pump pressure of 200 psi.	MRO2X – 4,320 GPD (16,654 LPD) MRO3X – 5,544 GPD (24,981 LPD) MRO4X – 7,401 GPD (33,308 LPD) MRO5X – 9,244 GPD (34,822 LPD) (Gallons Per Day / Liters Per Day)

Connections	Feed = 3/4" plain hose Product = 1/2" plain hose Drain = 3/4" plain hose
Electrical Requirements	For the controller: 115V/60Hz GFI (Ground Fault Interrupter) For the pump: 208V, 230V, or 460V three phase/15 Amp fused disconnect. 220V single phase/15 Amp fused disconnect
Dimensions Packaged Dimensions not Packaged	64- 1/2" H x 42" W x 38" D 59"H x 26"W x 25 1/2"D
Shipping Weight / Operation Weight	MRO2X 340 - 390 lbs. / 265 lbs MRO3X 370 - 420 lbs. / 300 lbs MRO4X 400 - 450 lbs. / 335 lbs MRO5X 430 - 480 lbs. / 370 lbs

### Materials that Contact Product Water:

ABS	Polyethylene
Acrylic	Polypropylene
Carbon	Stainless Steel
Nylon	Thin Film Composite Membrane (polyimide)
PVC	Tygon
Polyester	

All of the above listed materials meet FDA and/or NSF standards.

## **2.2 POWER RATINGS**

	Voltage	Frequency	Phase	Max Amp Draw
Controller	115	60 Hz	Single	10
2X-4X401 Pump	220	60 Hz	Single	12
2X-4X402 Pump	208	60 Hz	Three	8.8
2X-4X403 Pump	230	60 Hz	Three	7.6
2X-4X404 Pump	460	60 Hz	Three	3.8
5X402 Pump	208	60 Hz	Three	12
5X403 Pump	230	60 Hz	Three	10.1

## **2.3 MRO OUTPUT WATER QUALITY**

The physician in charge of dialysis has the ultimate responsibility for selecting the maximum allowable levels of chemical contaminants in the water, and, also, is responsible for monitoring the water. The AmeriWater MRO System is designed to produce water that meets or exceeds ANSI/AAMI RD62 requirements.

### **Thin Film Composite Membrane**

<b>Contaminants</b>	<b>Percentage Removal</b>
Calcium	99.5
Magnesium	99.5
Sodium	98.0
Potassium	97.0
Fluoride	87.0 - 93.0
Nitrate (NO <sub>3</sub> )	60.0 - 75.0
Sulfate	99.5
Copper	98.0 - 99.0
Barium	96.0 - 98.0
Zinc	98.0 - 99.0
Aluminum	98.0 - 99.0
Arsenic	94.0 - 96.0
Lead	96.0 - 98.0
Silver	93.0 - 96.0
Cadmium	96.0 - 98.0
Chromium	96.0 - 98.0
Selenium	94.0 - 96.0
Mercury	96.0 - 98.0
Antimony	96.0 - 98.0
Beryllium	96.0 - 98.0
Thallium	96.0 - 98.0

### **PT401 Antiscalant/Scale Inhibitor**

<b>Contaminants</b>	<b>Chemical Feed System</b>
Membrane Scale Control	Not to exceed 40 ppm

## **2.4 TEMPERATURE CORRECTED MRO PRODUCTION RATES**

MRO membrane performance is affected by water temperature. The Product Water Flow Rate and Output decreases as the temperature of the Incoming Tap Water decreases.

## **2.5 ENVIRONMENTAL/TRANSPORT CONDITIONS EXPECTED**

### **ENVIRONMENTAL CONDITIONS ANTICIPATED**

This device is intended to be used under the following conditions:

Indoor use;

Altitude up to 2000 m;

Temperature between 5°C and 40°C;

Maximum relative humidity 80% for temperatures up to 31°C decreasing linearly to 50% relative humidity at 40°C;

MAINS supply voltage fluctuations up to  $\pm 10\%$  of the nominal voltage;

Transient overvoltages present on MAINS supply = CATEGORY II;

Applicable RATED POLLUTION degree 2.

### **TRANSPORT CONDITIONS ANTICIPATED**

Altitude up to 2000 m;

Temperature between 5°C and 40°C;

Maximum relative humidity 80% for temperatures up to 31°C decreasing linearly to 50% relative humidity at 40°C;



# SECTION 3, COMPONENTS AND SCHEMATICS

## 3.1 EXTERNAL FRONT VIEW

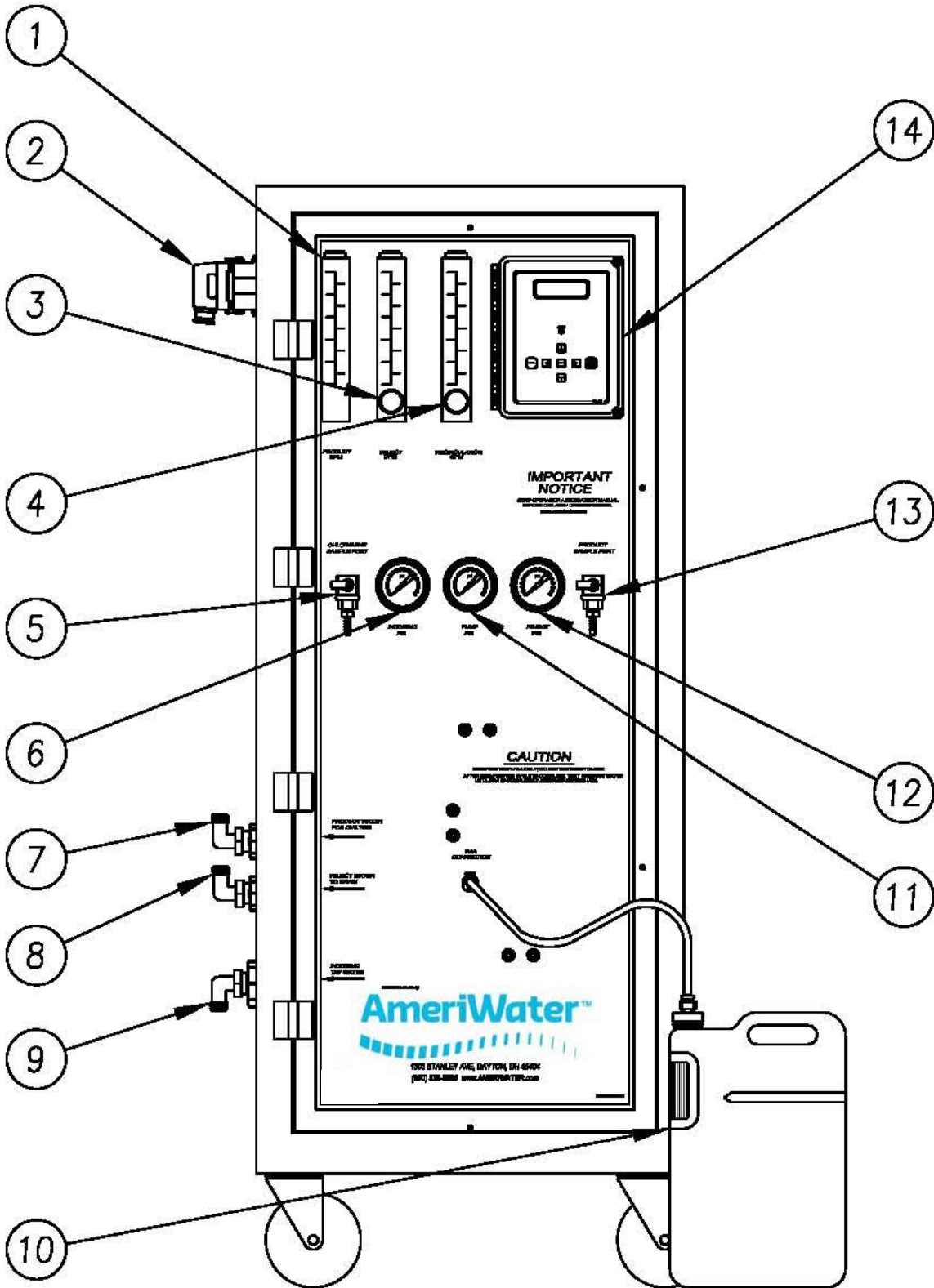

## **IDENTIFICATION OF COMPONENTS (EXTERNAL FRONT VIEW)**

1. **PRODUCT GPM:** Rotameter that measures the flow of the Product Water For Dialysis in gallons per minute (GPM).
2. **SIDE ENTRY HOOD:** External wire installation for float level switches, pretreat lockout and RO alarm relay connectors; (See Section 7).
3. **REJECT GPM WITH VALVE:** Rotameter with valve to control the flow of the Reject water to drain, in gallons per minute (GPM).
4. **RECIRCULATING GPM:** Rotameter with valve to control the flow of water being recirculated back before the pump, in gallons per minute (GPM).
5. **INCOMING TAP WATER TEST PORT:** Valve for taking sample of feed water before the RO.
6. **INCOMING TAP WATER PSI:** Gauge that measures the pressure (in pounds per square inch) of the Incoming Tap Water.
7. **PRODUCT WATER FOR DIALYSIS:** Connection carrying Product Water For Dialysis.
8. **REJECT WATER TO DRAIN:** Connection carrying Reject to the drain.
9. **INCOMING TAP WATER:** Hose carrying Incoming Tap Water that is to be treated by the RO.
10. **PAA JUG:** Plastic jug to mix hydrogen peroxide/peroxyacetic acid (PAA) disinfecting solution and water for sanitizing the system; pre-marked with a red Fill Line to indicate how much water to add.
11. **REJECT PSI:** Gauge that measures the pressure (in pounds per square inch) of the water coming from reject side of the membranes.
12. **PUMP PSI:** Gauge that measures the pressure (in pounds per square inch) of the water coming from the pump feeding the membranes.
13. **PRODUCT WATER TEST PORT:** Valve for taking sample of Product Water.
14. **CONTROLLER:** Control mechanism for the RO. See Section 6.

### 3.2 INTERNAL REAR VIEW

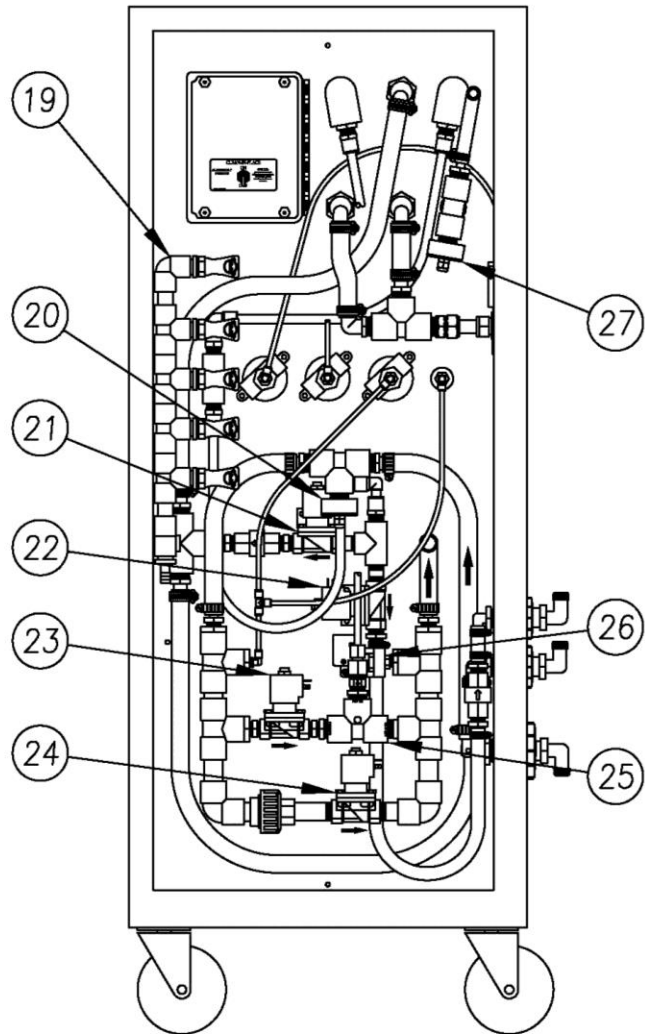
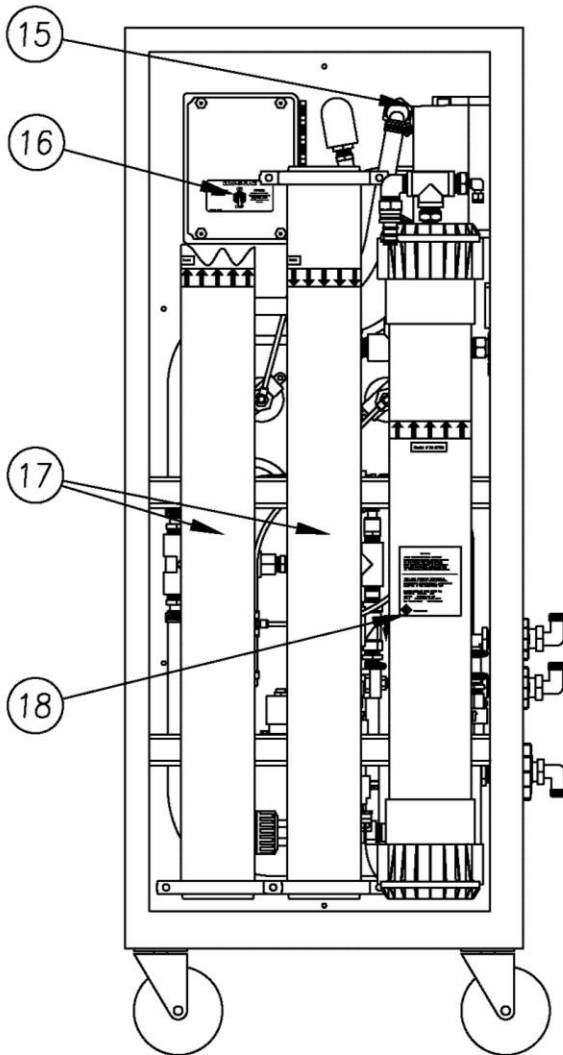

## IDENTIFICATION OF COMPONENTS (INTERNAL REAR VIEW)

15. **MOTOR CONTACTOR/OVERLOAD RELAY:** Starts and stops the pump motor and protects the motor from overload.
16. **CLEAN IN PLACE SWITCH (ALARM FAULT OVERRIDE):** When the Clean In Place (CIP) switch is placed to the ON position, all RO+ fail-safe modes are disabled for low-pressure membrane cleaning with the optional AmeriWater Clean In Place system (P/N 00CIP2). The controller will display a warning that the CIP mode is active.
17. **MEMBRANE:** Fiberglass wrapped, spiral-wound, thin film composite membrane for reverse osmosis.
18. **PUMP:** Provides the driving pressure for the reverse osmosis system.
19. **PRODUCT HEADER ASSY:** This header directs all product water from the membranes to the flow meter.
20. **INCOMING CONDUCTIVITY SENSOR:** Cell that reads the quality of the feed water.
21. **PRODUCT TO DRAIN SOLENOID:** Opens when water quality is below set point.
22. **PRODUCT TO USE SOLENOID:** Closes when water quality is below set point.
23. **DISINFECT SOLENOID ASSEMBLY:** Opens to allow the hydrogen peroxide/ peroxyacetic acid mixture to draw into the system to soak for the sanitize cycle.
24. **FEED SOLENOID ASSEMBLY:** Opens when the MRO system is on to allow water to feed through the system, closes when the system is OFF.
25. **DISINFECT EJECTOR:** Causes suction to draw solution from PAA jug when the Disinfect Solenoid is opened.
26. **LOW PRESSURE SWITCH:** Switch to protect the pump in the event that the feed pressure drops below 20 PSI.
27. **PRODUCT CONDUCTIVITY SENSOR:** Cell that reads the quality of the product water.

### 3.3 ELECTRICAL DIAGRAM, MRO2X, MRO3X, MRO4X & MRO5X

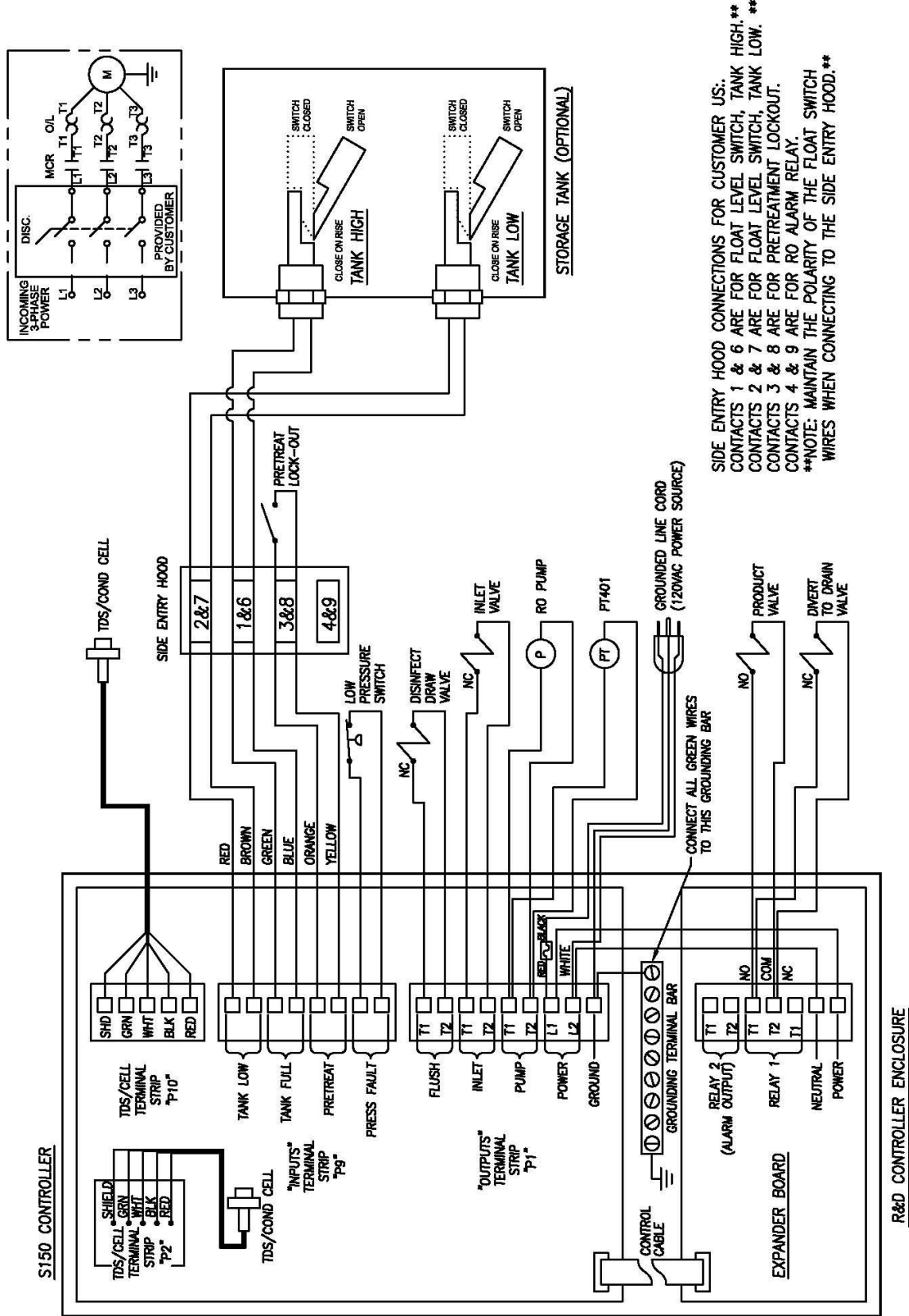

### 3.4 FLUID DIAGRAM, MRO2X, MRO3X & MRO4X

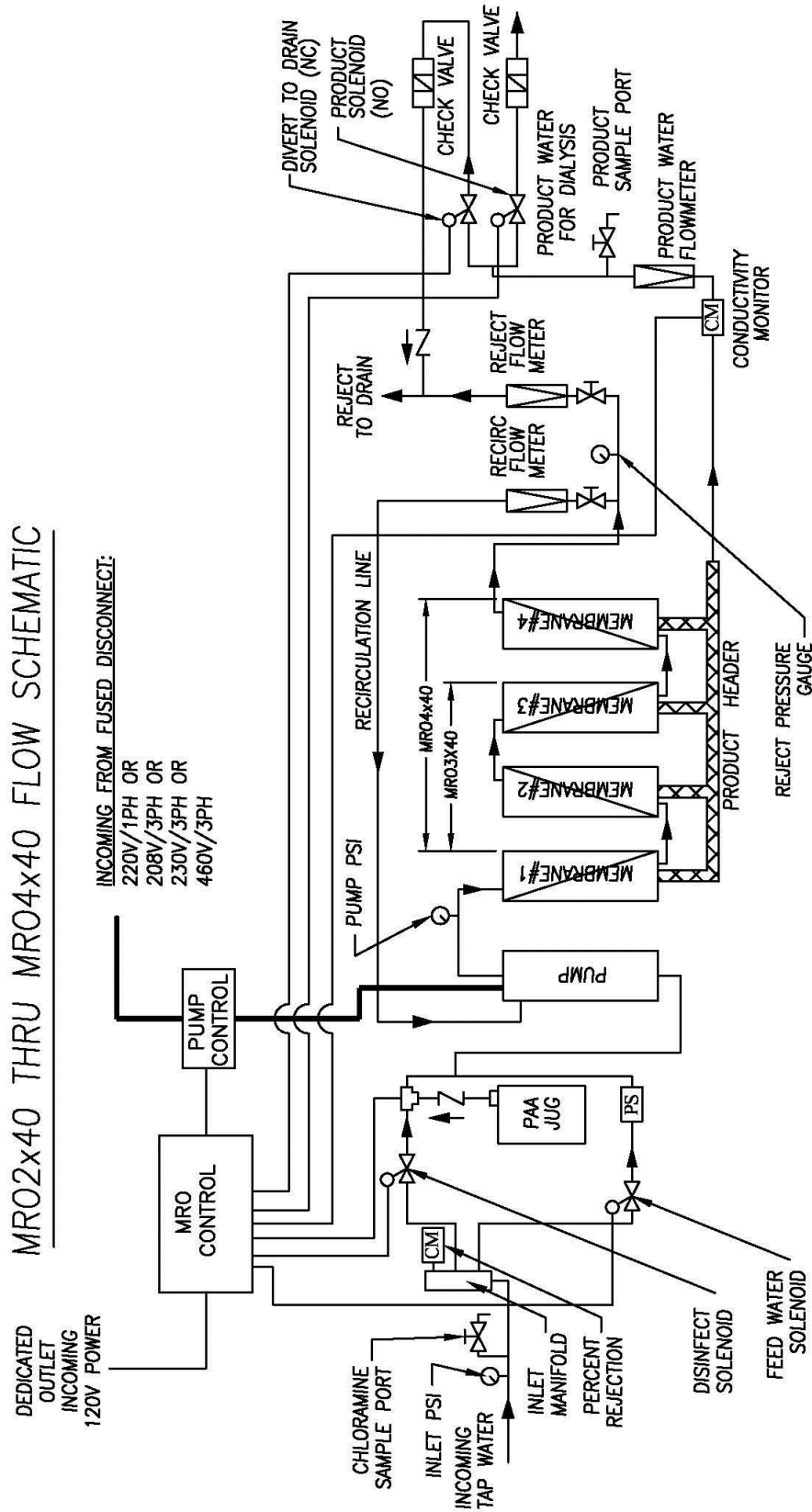

### 3.5 FLUID DIAGRAM MRO5X

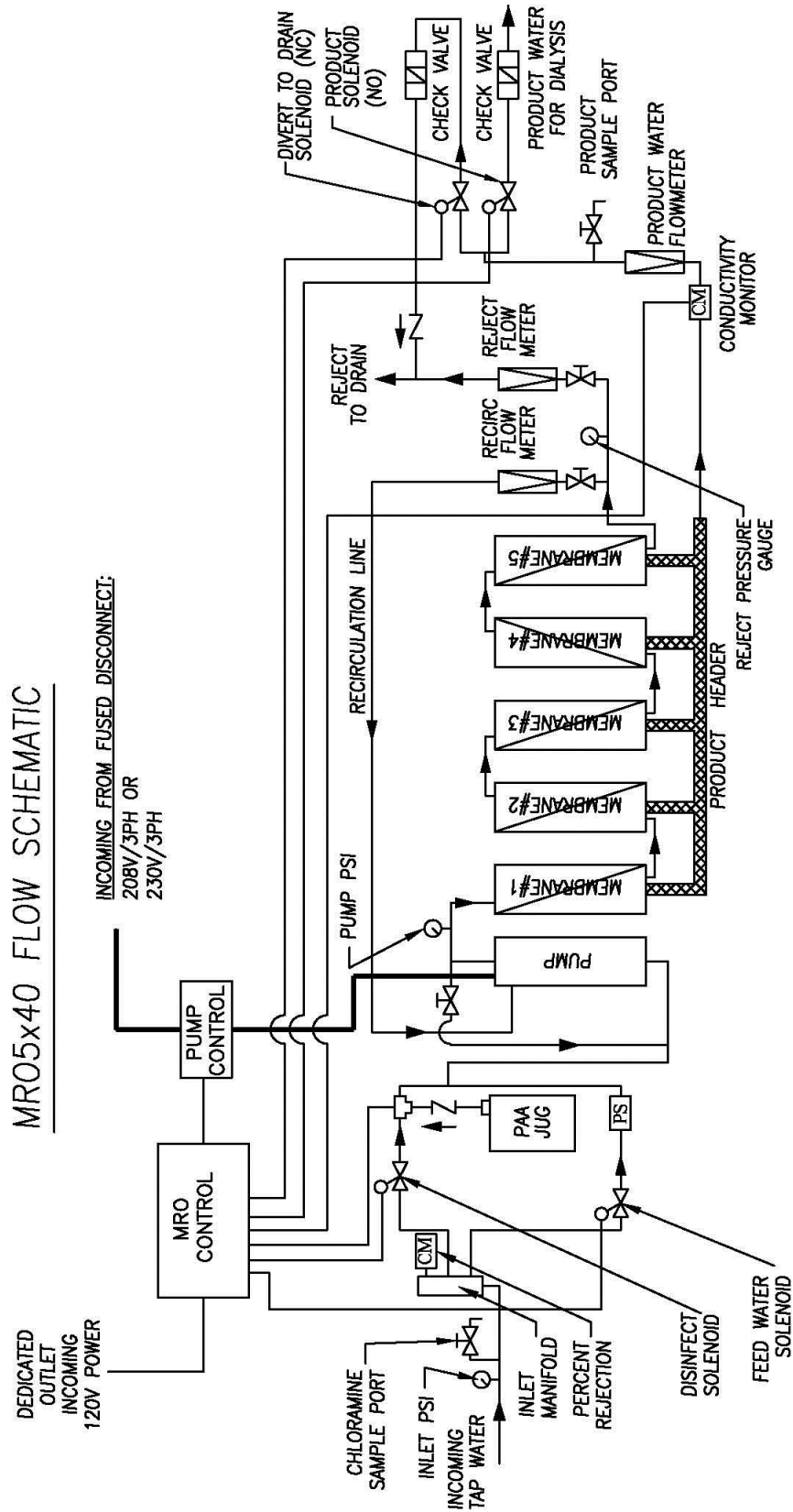

## SECTION 4, MRO STARTUP & OPERATION

### 4.1 CAUTION

**NOTE:** This entire Operations Manual should be read before operating or servicing the MRO system. The Operations Manual should then be kept near the system and used as a reference and troubleshooting guide.

**WARNING:** This Reverse Osmosis System (RO) contains a preservative solution to prevent microbiological growth and freezing. Discard all product water for at least two hours of operation before placing the RO in service.

**CAUTION:** No person should attempt to operate or service the MRO without prior authorization or instruction from your medical facility director.

The following operating or water supply conditions could cause an accident or the MRO system to fail:

1. The electrical source must be single phase, 3-conductor type provided with a hospital grade receptacle and a ground fault interrupter (GFI) at 115V, 60Hz. The proper polarity and ground integrity must be initially checked and thereafter maintained. Failure to do so may result in electrical shock to the operator or patient. It is suggested that the MRO be placed on an electrical supply with emergency backup.
2. The MRO must only be plugged directly into a GFI receptacle. It must not be plugged into an extension cord or power strip that could cause low amperage.
3. All local plumbing and electrical requirements should be met.



**To avoid electrical shock, always unplug the MRO system before opening the face of the electrical controller.**

4. Incoming water should be between 41° F and 90° F (5° C and 33° C). It is not recommended to use water at temperatures below 41° F (5° C) because it will reduce membrane performance significantly. Use only the cold water supply unless using an automatic blending valve to get 77° F (25° C) water. Never use water warmer than 90° F (33° C).
5. Water with silt density index (SDI) above 5 SDI will foul the membrane.
6. It is important to test for chlorine and chloramines at the CHLORAMINES SAMPLE PORT before each use of the system. Chlorine will deteriorate the membrane and cause system failure. It is recommended to use a Total Chlorine test kit, such as Water Check 2 Low Level Chlorine/Chloramines Test Strips (P/N 97CM20201).
7. Incoming tap water pH should be within EPA National Secondary Drinking Water Regulations of 6.5 - 8.5. Incoming tap water with pH higher or lower than the regulation may cause higher conductivity in the product water. If the water changes drastically, the membrane will be harder to clean. Periodically check the pH of the incoming tap water to



verify that it is within the specified range (pH Water/Bicarbonate/Dialysate Test Strips P/N 97PH20901).

**CAUTION:** Mixing chlorine and hydrogen peroxide/ peroxyacetic acid causes a toxic chemical reaction. Never allow them to mix! Do not use chlorine to disinfect the system!

8. Use only the exact amount of hydrogen peroxide/ peroxyacetic acid disinfectant solution (PAA) and in proper dilution during disinfection of the system.
9. It is important to test for PAA in the Product Water after rinsing during disinfection of the system. Do not use the system until all traces of the disinfecting solution in the Product Water are gone.

**CAUTION:** Never operate the MRO connected to dialysis machines if the water conductivity exceeds the set point, indicating Poor Quality!

10. Always maintain water flow and pressure to avoid damage to the pump.
11. Minimum feed pressure is 20 PSI (while the MRO is in operation, with flow). Maximum feed pressure is 90 PSI.
12. If the system is operated without a micron prefilter, the membranes will foul.

**WARNING:** The Clean In Place Switch, located inside the cabinet on the back of the controller, must be in the OFF position during normal operation. If the Clean In Place Switch is left in the ON position during normal operation, all MRO fail-safe modes will be disabled, and damage to the MRO or injury to the patient may occur.

**13. Minimize the opportunities for bacterial growth between uses!**

Whenever the MRO is not used for a period of several hours, and connected to a Direct Feed Loop, the “Membrane Flush Feature” of the MRO should be programmed to be active when in the STANDBY mode (See section 5 for activating this feature).

Whenever the MRO is not used for a period of several hours, and connected to a Storage Tank of a Central System, the “Membrane Flush Feature” of the MRO should be programmed to be active when in the OPERATE mode (See section 5 for activating this feature). This feature will flush the MRO when the Storage Tank is full and the water level is maintained at the Tank Full High float switch by diverting the Product Water to drain.

Before determining a bacteria count, the MRO should be PLACED in FLUSH for 5 minutes (fully opened reject flow control knob), and then placed in OPERATE for 5 – 10 additional minutes after a period of non-use, but before taking a sample of the PRODUCT WATER. Bacteria are known to increase in population when water is not moving.

## **4.2 SAFETY FEATURES**

The MRO is equipped with several safety features for the benefit of both the user and the patient. They consist of the following:

1. Disinfection using (PAA) disinfecting solution instead of formaldehyde increases safety and avoids health risks associated with formaldehyde. PAA produces no harmful by-products or side effects, thus it is safer for patients. Using PAA does not require additional ventilation, and disposal is safe and easy. Important information regarding the usage and handling of PAA is listed in Section 5.3, A WORD ABOUT HYDROGEN PEROXIDE/PEROXYACETIC ACID, and in PAA Materials Safety Data Sheet. Please read them carefully.
2. INCOMING TAP WATER, PRODUCT WATER and REJECT WATER TO DRAIN hoses are labeled to prevent incorrect connections.
3. Low pressure shutdown protects the pump if the feed pressure drops below 20 PSI.
4. An audible alarm sounds whenever water quality drops to an unacceptable level.

**WARNING:** The AmeriWater model MRO 2X through 5X is considered a non-portable device. It can be connected to a Direct Feed Loop system or a Storage Tank system. For this reason, there is a divert to drain on this model. **TERMINATE TREATMENT IMMEDIATELY IF WATER QUALITY FALLS OUT OF SPECIFICATION WHEN NO STORAGE TANK IS BEING USED.** The Product water will divert to drain as long as the conductivity is out of specification (no water will be sent to the Storage Tank). The poor quality alarm for the MRO will sound, but the water that is already in the storage tank can continue to be used.

### 4.3 INITIAL STARTUP

**WARNING:** This Reverse Osmosis System (RO) contains a preservative solution to prevent microbiological growth and freezing. Discard all product water for at least two hours of operation before placing the RO in service.

1. Lock the two front casters so that the RO+ will remain stationary during startup.
2. Remove the protective covers from the PRODUCT WATER, REJECT WATER TO DRAIN and INCOMING TAP WATER barbed fittings on the side of the MRO.
3. Slide the hose clamps over the hoses that were provided in the installation package for holding the 3 hoses in place on the MRO.

4. Slip the INCOMING TAP WATER, PRODUCT WATER and REJECT WATER TO DRAIN hoses over the appropriate barbed fitting, then secure each with a hose clamp.

**CAUTION:** To assure proper assembly, hoses **MUST** be fully inserted over the barbed area and a little beyond for the clamp to hold in the “necked-down” area of the barbed fitting.

5. Connect the MRO INCOMING TAP WATER hose to the potable cold water supply using the Incoming Tap Water hose and fittings supplied. If blending both warm and cold water to improve product flow rate, do not exceed 90° F (33° C).
6. The REJECT WATER TO DRAIN hose coming out of the MRO system is for reject water. The water from this hose will always go down a sink drain. Leave at least a 2" air gap between the hose and the drain to prevent contamination or siphoning.
7. The PRODUCT WATER hose should also be secured to the sink until the start-up flush and initial disinfection cycle are completed, and the water quality is in the good range (below the conductivity setpoint, and not in alarm).
8. Open the access cover and make sure that the “CIP” switch is in the “OFF” position.
9. Plug the power cord into a dedicated 115-volt GFI receptacle.
10. The high voltage power cord must be connected to an appropriately sized disconnect for the voltage and the phases used. Connection to a wall disconnect must be done by a qualified electrician.

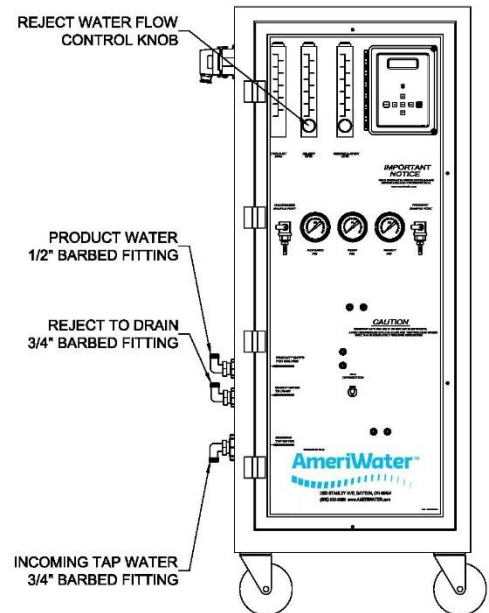

11. If a plug on the high voltage power cord has been installed, there must be a matching “twist lock” high voltage polarized receptacle that has been installed by a qualified electrician.

**For 3 phase applications, the 3-wire connections must be verified to give the correct rotation on the MRO pump. If not, specified pressure cannot be obtained, and the pump will quickly overheat.**

12. Turn on the potable water supply to the MRO. Allow the membranes to fill with water. This may take up to 5 minutes. Failure to do so may cause damage to the MRO.
13. Turn on the MRO by pressing the POWER key, and allow it to run making sure the water is properly flowing out the Reject and Product hoses.
14. Turn the REJECT FLOW CONTROL KNOB located at the bottom of the Reject Flow meter counter-clockwise to allow the MROZ to run in full-flow Reject flush for about 15 minutes.
15. After 15 minutes, turn the REJECT FLOW CONTROL KNOB clockwise so that the Reject flow is approximately equal to the Product water flow. Allow the product water to flow to drain for 2 hours to ensure that all preservative is rinsed out of the system. Check for leaks during this time.

**NOTE:** The MRO conductivity alarm may sound, which is normal when the MRO is in FLUSH. Press the ALARM SILENCE key on the MRO controller to silence the alarm. The alarm will restart after a 3 minute delay.

16. The conductivity value, after flushing and being put back into the service mode, must be within the acceptable limit.
17. After a thorough flushing of the preservative, the MRO must be disinfected prior to being put into service for dialysis use. **(See Disinfecting The System, Section 5).**
18. When all disinfection procedures have been completed, turn on the feed water supply.
19. Press the POWER key (the display will show OPERATING after a 10 second delay).

**NOTE:** The conductivity may alarm for a few seconds before dropping into the desired range.

**WARNING:** Do not use the MRO to feed a dialysis machine until all specifications are met.

20. Press the POWER key (the display will show STANDBY). Connect the PRODUCT WATER hose to the Direct Feed Loop or Storage Tank inlet. **(Be sure to connect the Product Water hose aseptically).**

**CAUTION:** Although the water treatment system may produce water of sufficient quality to meet the requirements of AAMI standards, distribution of the water may degrade its quality to the point where it no longer meets the requirements of this standard. AmeriWater offers information about ultra pure water piping to prevent the degradation of product water in a water loop or central system.

## **4.4 SYSTEM SHUTDOWN**

Ordinarily, an MRO2-5X is connected to a water use system that is used continually or very frequently. Therefore, frequent shutting down is not necessary. Most usually, the MRO is connected to a Direct Feed Loop or Storage Tank of a Central System. If so, the MRO should be cycled using the “Membrane Flush” feature in the controller of the MRO. This will allow an MRO connected to a Direct Feed Loop while in STANDBY to start and circulate Product Water through the loop at some predetermined frequency for a predetermined amount of time (every 4 to 6 hours for 15 minutes, for example). This allows the water to be “freshened” in the MRO and loop. When the MRO is connected to the storage tank of a central system, the MRO shall remain in OPERATION. When the “Membrane Flush” feature is active, the MRO will cycle on some predetermine frequency to send the Product Water through the “Divert to Drain” feature of the MRO to the drain. This will only occur when the “Tank Full High” limit switch indicates that the tank is full for a long period of time (usually around 6 hours) since the last use of the MRO.

If the MRO must be shut down for an extended period, however, use the following instructions:

1. Before turning off the MRO by pressing the POWER key, turn the REJECT VALVE counter clockwise to allow a full-flow “FLUSH” 5 minutes. This will flush the concentrate out of the system.
2. Press the POWER key (the display will show STANDBY).
3. Turn off the potable tap water supply to the system.
4. Disconnect the PRODUCT WATER hose from the Direct Feed Loop or Storage tank, and the INCOMING TAP WATER hose from the potable tap water supply. The hoses may be connected together to prevent dirt from entering the hoses.
5. Remove the REJECT WATER TO DRAIN HOSE from the sink. The hoses and power cord may be secured by the hose strap on the side of the MRO for storage or transport of the MRO.
6. Store the system until next use.
7. When transporting the MRO, push or pull the system carefully, because it may be top-heavy and may easily tip over.

# SECTION 5, DISINFECTING THE SYSTEM

## 5.1 DISINFECTING THE SYSTEM

The MRO system should be disinfected according to specifications of your medical facility director. As a general guideline, AmeriWater recommends that the system should be disinfected at least monthly. In addition, AmeriWater recommends that the system be disinfected if it has not been: used for 24 hours; flushed at least every 8 hours; or “packed” in BioTrol for storage up to two weeks.

**Be sure to refer to the Start-Up Log in Section 4.5. This will help you verify that all steps are performed and recorded to disinfect the system properly.**

### 5.1.a. DISINFECTING THE MRO ONLY OR WITH A SMALL LOOP SYSTEM

**Note:** A “small loop system” can be defined as one where all points in the loop can easily be disinfected by drawing less than 5 containers of PAA solution into the MRO and loop system. If this can’t be accomplished, refer to section 5.1.b that describes disinfecting a “large” loop system.

1. Switch off the MRO by pressing the POWER key (the display will show STANDBY).

Disconnect any dialysis machines from the Direct Feed Loop or Central System from the water loop before starting the disinfection procedure. Disinfectant for the MRO or loop must never be allowed to enter a dialysis machine.

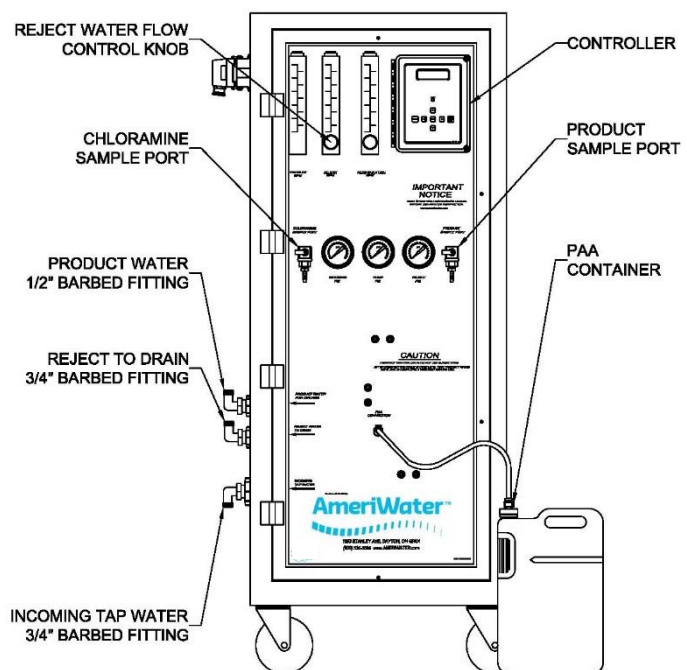

**WARNING:** The disinfection mode will allow PAA to flow through the PRODUCT WATER hose. This is to allow disinfection of the hoses and the connected “small” direct-feed water loop.

**If the “small” direct-feed water loop is to be disinfected with the MRO, fill and draw the PAA solution container at least twice and up to 5 times to allow sufficient volume into the loop for complete disinfection.**

- 3a. To disinfect only the MRO that is connected to a Storage Tank, disconnect the PRODUCT WATER hose from the tank and place along with the REJECT WATER TO DRAIN hose in a sink.

- 3b. To disinfect the MRO AND “small” direct-feed water loop, allow the PRODUCT WATER hose to remain connected to the “small” loop during the disinfection procedure, **but be sure all dialysis machines are disconnected during the disinfection procedure.**
4. Unscrew the cap assembly of the PAA container (plastic 2 ½ gallon container).
5. Put on rubber gloves, apron, and goggles.

**CAUTION:** Exposure to hydrogen peroxide/peroxyacetic acid concentrate or solution may cause severe chemical burns to the skin or eyes. Additional information regarding the safe handling of PAA is found in this section, on the Peracidin container, and in the material safety data sheet. Please read carefully before using.

6. Add 400 ml of 100% PAA disinfecting solution to the PAA Container, and fill with water to the red line (tap water or treated water may be used).
7. Screw the cap assembly securely back onto the PAA container.
8. Agitate the container in a circular motion for approximately 10 seconds.
9. Connect the PAA tubing male fitting into the quick disconnect fitting that is mounted on the front of the MRO (Figure 5.1).
10. Press and hold the LEFT ARROW key and then, press the RIGHT ARROW key. This will access the DISINFECT MODE. The controller display will show DISINFECT ENABLED and the keys can be released.
11. When in DISINFECT MODE, the signal from the conductivity cell is disabled. The Product Water for Dialysis will pass through and out the PRODUCT WATER hose laden with PAA disinfectant. If connected to a small direct feed loop, PAA disinfectant solution will, also, pass into the loop.
12. Pressing and holding the ENTER key will activate the disinfect function, draw PAA from the container and pump PAA solution through the MRO.
13. Adjust the REJECT flow control knob so that the PAA will be drawn into the MRO in about 2 minutes. (Figure 5.1) The REJECT flow amount will have to be determined the first time the PAA is drawn in, and noted the flow that will empty the container in about 2 minutes.
- 14a. Continue holding the ENTER key until the PAA container is empty, then immediately release the ENTER key.

- 14b. If disinfecting the MRO while connected to a small direct-feed loop:  
Draw a complete PAA container into the MRO (with the REJECT flow amount adjusted as needed described in step 12).

Release the ENTER key, then refill the PAA container, reconnect the PAA container to the MRO, press & hold the ENTER key, and draw the 2<sup>nd</sup> PAA container into the MRO, until empty. (Approximately ¼” of the solution will remain in the bottom of the plastic container). Avoid sucking air into the system.

**NOTE: The ENTER key must be held until all the PAA is drawn into the MRO.**

- a. **Avoid stopping and starting the disinfect function which may cause a thermal overload of the MRO pump.**
  - b. **Releasing the ENTER key may cause the system to loose its prime preventing all of the disinfectant from being drawn into the MRO.**
  - c. **Approximately ¼” of the solution will remain in the bottom of the PAA container. This is normal and may be emptied down the drain after the entire process is complete.**
15. Record on the Start-Up Log that this step was performed.
- 16a. The MRO (if not connected to a loop) should be filled PAA disinfecting solution. To ensure that PAA solution has been pumped through the MRO, use Peracid test strips (P/N 97hp20401):
- a. Using a test strip, test the water the REJECT WATER TO DRAIN hose, the result must be at least 1% (500 ppm).
  - b. Use another test strip at the PRODUCT WATER hose, the result must be at least 0.5% (250 ppm).
- 16b. If the MRO is connected to a small direct-feed loop during disinfection, then the entire loop must test positive for PAA throughout the loop. Using a fresh test strip at each dialysis machine water outlet, test the water. The result must be at least 0.5% (250 ppm).
- 16c. If the small direct-feed loop is using a Product Recovery, the presence of PAA must test positive at the Chloramine Sample Port at the front of the MRO in addition to each dialysis machine water outlet. The result must be at least 0.5% (250 ppm).

**NOTE:**

Water loop systems will vary in size and in volume for each installation. If a small loop is to be disinfected along with the MRO, then PAA must be drawn into the MRO using only the disinfection function, pumped into the loop by the MRO through the



PRODUCT WATER hose connection. After each container of PAA solution is drawn into the MRO, then the MRO must be stopped without delay, and each water outlet must be tested for PAA at the minimum amount. Continuing to run the MRO after all the PAA solution is drawn out of the PAA container will only result with diluting the strength of the PAA, which reduces the disinfecting capability.

If the PAA at each water outlet has not been found to be positive at the minimum required amount, another container must be drawn into MRO, and into the loop, until the minimum strength is tested and verified using a PAA test strip. If the minimum required level of PAA cannot be achieved after a reasonable number of volumes from the PAA container (usually around 5, or determined by your facility manager), refer to the “large” loop disinfection procedure outlined in the following section.

**UNTIL THE PAA IS FOUND TO BE POSITIVE AT EACH WATER OUTLET TEST POINT AT 0.5% MINIMUM, THE LOOP SYSTEM CANNOT BE RELIABLY DISINFECTED.**

**WARNING: DO NOT RECIRCULATE THE PAA SOLUTION FROM THE LOOP THROUGH THE MRO AND THEN, BACK INTO THE LOOP USING THE “CIP” SWITCH IN THE “ON” POSITION WHEN THE MRO IS IN THE “DISINFECTION” MODE.**

17. Label the MRO with appropriate WARNING signs (Example: “DO NOT USE / CONTAINS DISINFECTANT”).
18. Leave the MRO in the DISINFECT ENABLED mode, and allow the PAA solution to soak for 60 minutes within the MRO (and the loop, if connected to one).

**WARNING: Soaking longer than twelve hours may cause damage to the membrane.**

19. Record the Start and Stop times on the Log to have a record of how long the membrane soaked in PAA disinfecting solution.
20. After the required soak time is achieved in the DISINFECT mode, flush the residual PAA from the disinfectant draw plumbing
  - a. Rinse and fill the PAA Container to the red line with dechlorinated water from the Incoming Tap Water Test Port and connect the PAA tubing to the PAA connection on the front of the RO+.
  - b. Press and hold the LEFT ARROW key and then, press the RIGHT ARROW key. This will access the DISINFECT MODE. The controller display will show DISINFECT ENABLED and the keys can be released.
  - c. Press and hold the ENTER key to turn on the Disinfect Draw function and THE DISPLAY WILL READ **DISINFECT ENABLED DRAW**. Continue to hold the ENTER key, until all of the water is drawn in and you begin to see air bubbles in the draw tube. This will flush out any residual PAA left in the injection plumbing.

- d. Disconnect the PAA Container PAA tubing from the PAA connection on the front of the RO+.
21. Press the ALARM SILENCE/RESET key to exit the DISINFECT Mode and verify that the MRO is off (STANDBY).
22. DO NOT reconnect the PRODUCT WATER hose at this time!
23. Turn on the MRO by pressing the POWER key. Open the REJECT VALVE to allow full flow of REJECT WATER. Record the Start time on the Startup Log. Allow the machine to run at this setting for at least 15 minutes.

**WARNING:** Do not connect to any dialysis machine at this time. The water quality may register good, but it is possible that some residual PAA disinfecting solution is still in the system. All of the disinfecting solution MUST be completely flushed out before the system is reconnected to any dialysis machine.

24. After rinsing with the REJECT VALVE allowing full flow for at least 15 minutes, turn the REJECT VALVE clockwise until the REJECT flow is approximately equal to the PRODUCT flow (normal operation reject flow). Allow the MRO to run for 15 more minutes.
25. After the first 30 minutes, repeat 15 more minutes of full flow through the REJECT VALVE + 15 minutes of operation a normal operation reject flow. This will give a total of 60 minutes of running time to remove the disinfectant. Begin to test for the presence of PAA with residual test strips (**Renal Check PX Test Strips (P/N 97PX20501)**) at all water outlet points (if connected to a loop).
- 25a. If the MRO is not connected to a loop, periodically test for the presence of residual PAA at the ends of the REJECT and PRODUCT WATER hoses as the water exits into the sink until no trace of PAA is detected by the residual test strips.
- 25b. If the MRO is connected to a closed end loop dumping through a relief valve to drain, periodically test for the presence of residual PAA at each water use outlet, and where the relief valve is dumping to drain until no trace of PAA is detected by the residual test strips.
- 25c. If the MRO is connected to a loop that is being recirculated back through a Product Recovery valve and then, back into the MRO, periodically test for the presence of residual PAA at each water use outlet AND at the CHLORAMINE SAMPLE PORT (at the front of the MRO) until no trace of PAA is detected by the residual test strips.

**WARNING:** Continue rinsing and testing with test strips until all test strips show a negative residual result (no color change) to ensure that there are NO traces of PAA disinfecting solution remaining in the entire water system. AmeriWater recommends using **Renal Check PX Test Strips (P/N 97PX20501)**

26. Record the Stop time on the Startup Log to have a record of how long it takes for the disinfecting solution to completely rinse out. Place a checkmark on the log to verify that

residual PAA tested negative.

27. Disinfection is complete. Pull an AAMI sample.
28. If the MRO was disconnected during disinfection from the loop or storage tank, it can be reconnected for use once it is producing water within the acceptable conductivity range.

**WARNING:** The PAA Container PAA tubing must remain disconnected from the PAA connection on the front of the RO+ during patient treatment!

**WARNING:** Although it is a necessity to use a carbon filter to remove chlorine and chloramines from the incoming water, the carbon filter that is up-stream of the MRO, is a potential source of bacteria. It is very important that backwashing carbons be frequently backwashed and that the MRO is put into fast flush for 5 minutes, minimum, before every use to minimize the bacteria growth. An MRO that seems to be quickly re-infected after a thorough disinfection procedure may be getting re-infected from an insufficiently flushed carbon filter.

## **5.2 DISINFECTING AN MRO AND “LARGE” LOOP SYSTEM**

Disinfecting an MRO connected to a “large” loop system requires a different procedure. Rather than using the “**DISINFECT**” mode, the “**CIP**” (Clean In Place) mode will have to be accessed to assure complete circulation of the PAA through the MRO, through the large direct feed loop, and back to the MRO.

**WARNING:** Circulate the PAA solution only enough to achieve a minimum required amount of 0.5% at each water outlet in the loop system, and at the Product Recovery water return to the CIP2 tank. Once the minimum amount is achieved at all points, stop the circulation, and allow the PAA solution to soak in the system.

**Note:** The purposes of disinfecting and cleaning are distinctly different. With disinfection, exposure only to the disinfectant is required to destroy harmful bacteria. On the other hand, cleaning requires exposure by recirculation to chemically react and dissolve bio-film and/or mineral deposits that only can be removed by continuous re-exposure of the surfaces to the active chemicals that are in the cleaning solutions. Therefore, the MRO during “CIP” will continuously re-circulate and heat the chemicals (by the pumping action) through the CIP2 attachment until the procedure is stopped by direct intervention of the operator. This is good for cleaning, but great care must be exercised for disinfection.

1. To clean an MRO an **AmeriWater CIP2** cleaning system is required to be connected to the MRO.
2. Follow the instructions provided in the CIP2 system manual.

### **5.3 A WORD ABOUT HYDROGEN PEROXIDE/PEROXYACETIC ACID**

Do not use hydrogen peroxide/ peroxyacetic acid concentrate (PAA) after the expiration date. Using outdated PAA may cause incomplete disinfection. PAA loses effectiveness if not kept out of direct sunlight and/or the cap is not tightly sealed. Using ineffective disinfecting solution will cause incomplete disinfection. Using less than the required volume of PAA concentrate will result in incomplete disinfection.

#### **Disposal of Outdated Hydrogen Peroxide/Peroxyacetic Acid:**

Supplies Needed                      - a sink with a supply of tap water  
                                                 - rubber gloves, lab apron, and goggles  
                                                 - a supply of paper towels

1. Put on rubber gloves, apron and goggles.

**CAUTION:** Exposure to PAA concentrate or solution may cause severe chemical burns to skin or eyes.

2. Start a flow of cold tap water to dilute the PAA as it flows down the sink drain.
3. Slowly and carefully pour the disinfecting solution down the drain, taking care to avoid spills, splashes, or breathing the vapors.

**CAUTION:** Splashing PAA concentrate may cause severe chemical burns.

4. Rinse the emptied PAA container with tap water to remove all traces of the chemical. **Rinsing emptied containers is needed to protect waste handlers from accidental exposure to the chemical.**
5. Rinse the sink with tap water to remove residual disinfecting solution from the surfaces and flush the chemical from the sink traps.
6. Discard the emptied and rinsed container in a waste receptacle or set aside for recycling.
7. Inspect the area for spilled or dripped disinfecting solution. Wipe up small spills with a damp paper towel. Larger spills should be either flushed to drain with water or removed with a water bucket and floor mop.

**WARNING:** Verify that there is no chlorine (bleach) in the water bucket or floor mop. Chlorine (bleach) will cause a severe chemical reaction when it comes in contact with PAA concentrate!

8. Rinse rubber gloves with tap water to remove any residues due to handling.
9. Return rubber gloves, apron, and goggles to their storage area.

## **5.4 MEMBRANE FLUSH FEATURE (AUTO FLUSH)**

The MEMBRANE FLUSH FEATURE is the preferred means for minimizing bacterial growth for the MRO2-5X during periods of low water usage. Ordinarily these sizes of MRO are connected to a loop or storage tank only having 1-2 days of non-use when dialysis procedures are not being carried out. The MRO2-5X can be set up to discourage microbiological growth by “flushing” periodically.

The Membrane Flush feature is disabled as a default from the factory for MRO2-5X models. Refer to the default setpoints in Section 6.4. If these default settings do not meet your particular need, then they can be changed. See Section 6.5 on how to change from the default settings.

<b>FLUSH MODE</b>	<b>RO PUMP</b>	<b>INLET VALVE</b>	<b>DIVERT VALVE</b>
3 (FOR STORAGE TANK APPLICATIONS)	ON	OPEN	ENABLED
4 (FOR LOOP APPLICATIONS)	ON	OPEN	DISABLED

**FLUSH MODE #3** assumes that the **MRO is connected to a storage tank** and, therefore, will divert the PRODUCT WATER to the drain. This minimizes bacterial growth and directs all the water to the drain, rather than refill the storage tank. **FLUSH MODE #3** will cause all the water to be diverted to drain for each MEMBRANE AUTO FLUSH cycle.

On the other hand, when an **MRO is connected to a Direct Feed Loop**, the PRODUCT water should be directed into the loop during the MEMBRANE AUTO FLUSH cycle to keep the water in the loop “fresh”. Setting the **FLUSH MODE for #4** will disable the DIVERT TO DRAIN feature, and the PRODUCT WATER will be circulated through the loop during each MEMBRANE AUTO FLUSH cycle. The MEMBRANE AUTO FLUSH will operate while the MRO is in the STANDBY mode, while connected to the loop even though no water is being used for dialysis.

### **SETPOINT SETTING**

Flush Type	6 (Off hours)
Flush Time	15 to 45 (minutes)
Flush Mode	3 (Inlet valve open, pump on)
Flush Interval	4 to 12 (hours)

The MRO must be connected to the electric power source, incoming water supply, and drain at all times for this feature to be operable.

The Flush Time and Flush Interval settings are recommended settings, but may be adjusted to fit your specific needs. Contact your AmeriWater representative for guidance.

# SECTION 6, MRO CONTROLLER

## 6.1 FRONT PANEL CONTROLS AND INDICATORS

FIGURE 6.1

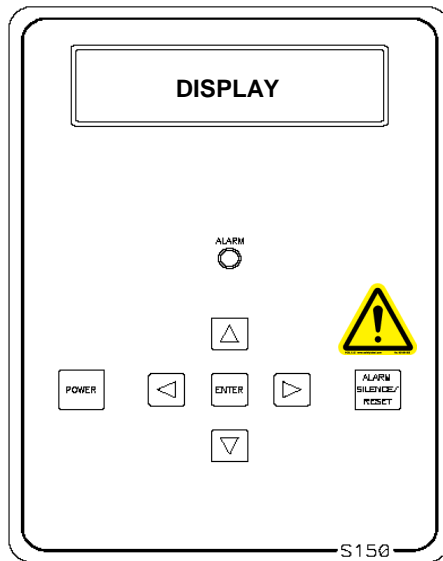

- |                                                                                                  |                                                                                                                                          |
|--------------------------------------------------------------------------------------------------|------------------------------------------------------------------------------------------------------------------------------------------|
| DISPLAY                                                                                          | - Shows status of system.                                                                                                                |
| ALARM LAMP                                                                                       | - Flashes when fault causes an RO system shut down.<br>On steady when a Setpoint is exceeded that does not cause an RO system shut down. |
| POWER KEY                                                                                        | - Places controller in operating or standby mode.                                                                                        |
| LEFT ARROW KEY                                                                                   | - Scrolls through Setpoints starting with first Setpoint.                                                                                |
| RIGHT ARROW KEY                                                                                  | - Scrolls through Setpoints starting with last Setpoint.                                                                                 |
| UP ARROW KEY                                                                                     | - Increases value of Setpoint.                                                                                                           |
| DOWN ARROW KEY                                                                                   | - Decreases value of Setpoint                                                                                                            |
| ENTER KEY                                                                                        | - Confirms entry of new Setpoint value                                                                                                   |
| ALARM SILENCE/RESET KEY                                                                          | - Push once for alarm silence and twice to reset system after a shutdown has occurred.                                                   |
| ACCESSING DISINFECT MODE                                                                         | - Push and hold the left arrow key, and then push the right arrow key.                                                                   |
| <b>NOTE: The J2 jumper must already be installed to make this an active mode. Ref. Fig. 6.2.</b> |                                                                                                                                          |
| DISINFECT                                                                                        | - Push the ENTER key and hold until all of the solution is drawn into the MRO.                                                           |

## 6.2 CONTROLLER OPERATION

### GENERAL OPERATION

The unit has 2 modes of operation, a standby mode and an operating mode that are controlled by the POWER key. In the standby mode, the unit is effectively off. All outputs are turned off and the display shows STANDBY. In the operating mode, the unit operates automatically. All inputs are monitored and the outputs are controlled accordingly. Pressing the POWER key will toggle the unit from STANDBY to OPERATE or from OPERATE to STANDBY. If power is removed from the unit, when power is reapplied, the unit will restart in the mode it was in when power was removed.

### DISPLAY

The display is a 2 line x 20-character backlit liquid crystal display. System operating status and sensor readings are shown on this display. Set point information can, also, be shown on this display.

### OPERATING STATUS MESSAGES

The operating status of the unit is shown on the top line of the display. The following list describes the items shown for the operating status.

STANDBY - The unit is in the STANDBY mode.

DELAY 99 - The unit is in the RO start delay. The number is the seconds remaining before the RO pump starts.

OPERATING - The RO unit is operating.

TANK FULL - The unit is shut down due to a tank full condition.

TANK FULL 99 - The unit is shut down due to a tank full condition. If the number is blinking, the tank full high switch has cleared, but the tank full low switch is still active. If the number is on steady, both tank level switches have cleared and the delay is counting down.

PRETREAT - The unit is shut down due to a pretreat lockout condition.

PRESS FAULT - The unit is shut down due to a pressure fault condition.

MEMB FLUSH 99 – Membrane Flush is active. The number is the minutes remaining in the flush cycle.

## CONDUCTIVITY

The Conductivity is shown on the top line after the unit operating status. When the unit is in STANDBY, because of a shut down condition, the reading is replaced with '----'. If the reading is over range, the reading is shown as '^^^' when in the OPERATE mode.

## OPERATING HOURS

The current operating hours are shown on the bottom line.

## TEMPERATURE

The current water temperature is shown on the bottom line to the right of operating hours. When the unit is in STANDBY due to a shut down condition, the reading is replaced with '---'.

## WARNING MESSAGES

Warning messages are also shown on the second line. If any warnings are active, the active warnings will alternate with the normal displays for the bottom line. The following lists the warning messages.

HI COND - The Conductivity reading has exceeded the programmed limit.

## TANK FULL OPERATION

The unit can be operated with 1 or 2 level switches. With 1 level switch, the switch is connected to the tank full high input. When this switch has been active for 5 seconds, the unit will shut down on tank full. TANK FULL will show on the display. When the tank full condition clears, the display will show TANK FULL 99. The number is the tank full restart time and the unit will restart when this delay times out.

For 2 level switch operation, the upper switch is connected to the tank full high input and the lower switch is connected to the tank full low input. When both switches are "open", the MRO unit will start. The MRO unit will continue to run when the water level rises, and while the lower switch becomes active (closed). When the upper switch becomes active (closes), after the 5 second delay, the MRO unit will shut down. TANK FULL will show on the display. When the tank level drops and the upper level switch clears, the display will show TANK FULL 99 and the MRO unit will remain off. The number is the tank full restart time and the number will blink until the lower level switch clears (opens). When the lower level switch clears (opens), the number will remain steady and the MRO will restart when the delay times out.

## TANK FULL RESTART

The tank full restart is the delay before the MRO unit starts when a tank full condition clears. This delay can be in minutes or in seconds. The TF Restart Setpoint selects seconds or minutes.



## TANK FULL OVERRIDE

A timed tank full override can be initiated when the MRO unit is shut down due to a tank full condition. Pressing the Alarm Silence/Reset key for 3 seconds during a tank full condition will enable the tank full override. The RO will start and TF OVERRIDE 9 will show on the display. The number is the minutes remaining in the override timer. When the override times out, the unit will return to the tank full shut down condition. The TANK FULL OVERRIDE will divert all water to the drain, whether the water quality is good or bad coming into the RO.

## PRESSURE FAULT

If the pressure fault input becomes active (closes) and stays active for the delay programmed in the PF Delay Setpoint, the unit will shut down for a pressure fault. The display will show PRESS FAULT, the alarm lamp will flash and the audible alarm will sound. The pressure fault can be cleared by pressing the Alarm Silence/Reset key twice.

## AUTO RESET

If a pressure fault shut down occurs and the Auto Reset Setpoint is programmed to 0, the unit will remain shut down until manually reset. If the Auto Reset Setpoint is programmed to a value greater than 0, the unit will automatically clear the pressure fault and attempt to restart after this delay times out.

## ALARM SILENCE

When a shut down occurs that causes the audible alarm to sound, the alarm can be silenced by pressing the Alarm Silence/Reset key once. The alarm will remain silenced for 3 minutes [180 seconds (AAMI RD62 standard)] when the Alarm Silence Setpoint is programmed to the factory default 3. If the Alarm Silence Setpoint is programmed to a value other than 3, the alarm will resound after this delay times out. Pressing the Alarm Silence/Reset key will silence the alarm and reset this delay.

## PRETREAT

If the pretreat input becomes active (closes) and stays active for 2 seconds, the unit will shut down in a pretreat lockout condition. PRETREAT will show on the display and the unit will remain shut down as long as the pretreat input is active.

## HIGH CONDUCTIVITY

If the Conductivity reading exceeds the limit programmed the Cond Limit Setpoint for the delay programmed in the Cond Delay Setpoint, the alarm lamp will light and the HI COND warning message will show on the display. This warning will clear when the Conductivity drops below the Setpoint.

When the High Conductivity warning message is active, the MRO will divert the PRODUCT WATER to drain (through the Reject hose), until the Product water conductivity goes back into the acceptable quality range.

## ALARM OUTPUT

The Expansion I/O relay 2 has been programmed to operate as an alarm relay. The relay will energize whenever a warning or alarm condition occurs. The relay will remain energized as long as the warning/alarm condition is active.

### **6.3 CONTROLLER ADJUSTMENTS**

Your controller has been calibrated prior to shipment and the conductivity set point has been preset based on an analysis of your water provided at the time of sale. It may be necessary to periodically calibrate the Conductivity. If the controller should require calibration, follow the instructions below. Please contact AmeriWater at 800/535-5585 or 937/461-8833 if you have any questions regarding the procedure.

#### CONDUCTIVITY CALIBRATION

Refer to Figure 6.2 for adjustment location (SPAN). To calibrate the Conductivity, place the cell in a known standard solution. Adjust the span adjustment for the correct reading. If the cell is installed, the unit can be calibrated by taking a sample from the PRODUCT TEST PORT and testing it with a known, calibrated meter. Adjust the span control until the reading matches the meter.

Refer to figure 6 for adjustment location. To calibrate the 2<sup>nd</sup> TDS / Conductivity, place the cell in a known standard solution. Adjust the span adjustment for the correct reading. If the cell is installed, the unit can be calibrated by taking a sample of the water and testing it with a known, good meter. Adjust the span control until the reading matches the meter.

#### DISPLAY ADJUSTMENT

The display contrast can be adjusted for best viewing by adjusting control R3. This control is located toward the upper right corner of the board, just to the left of the cell connector.

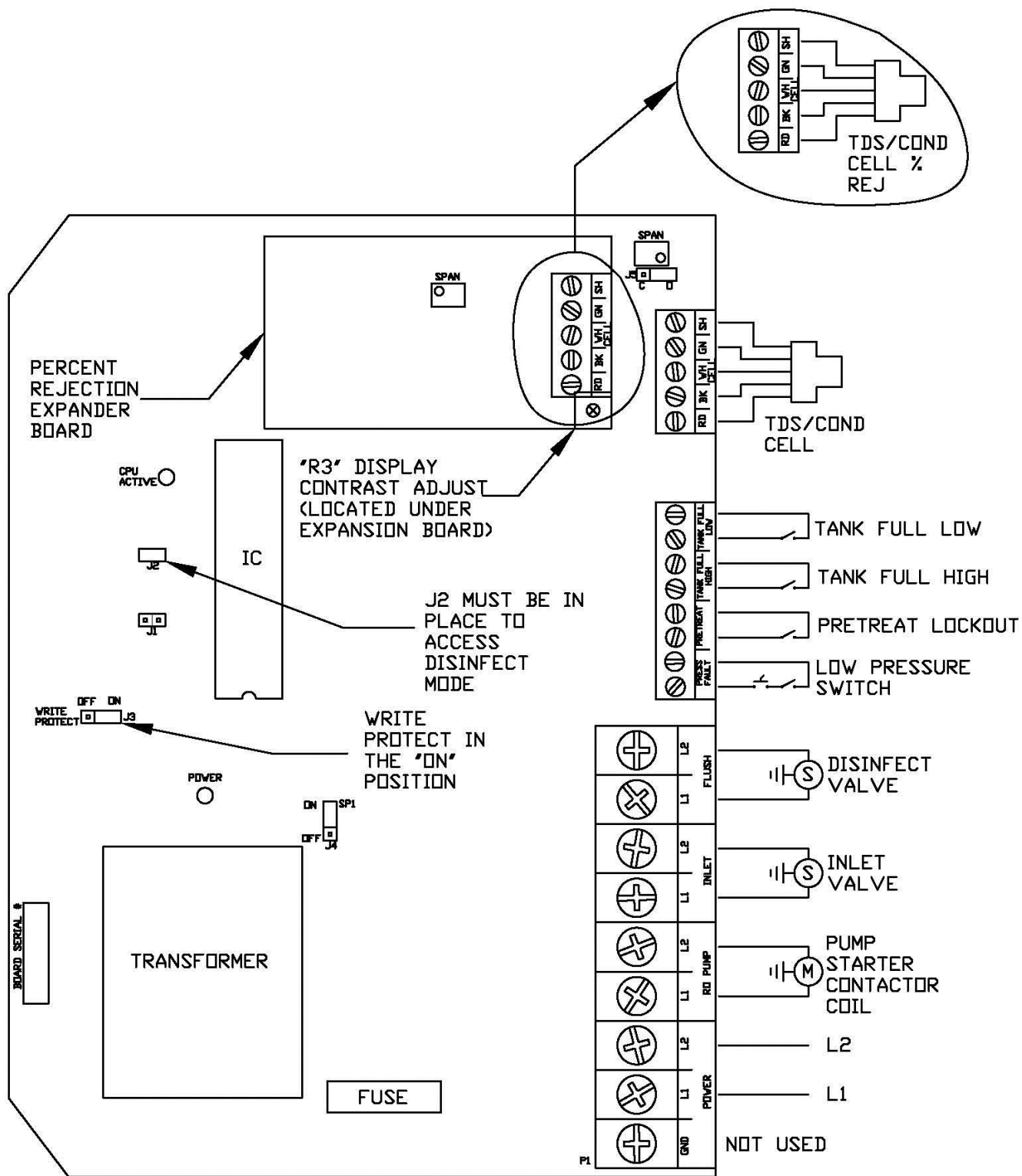
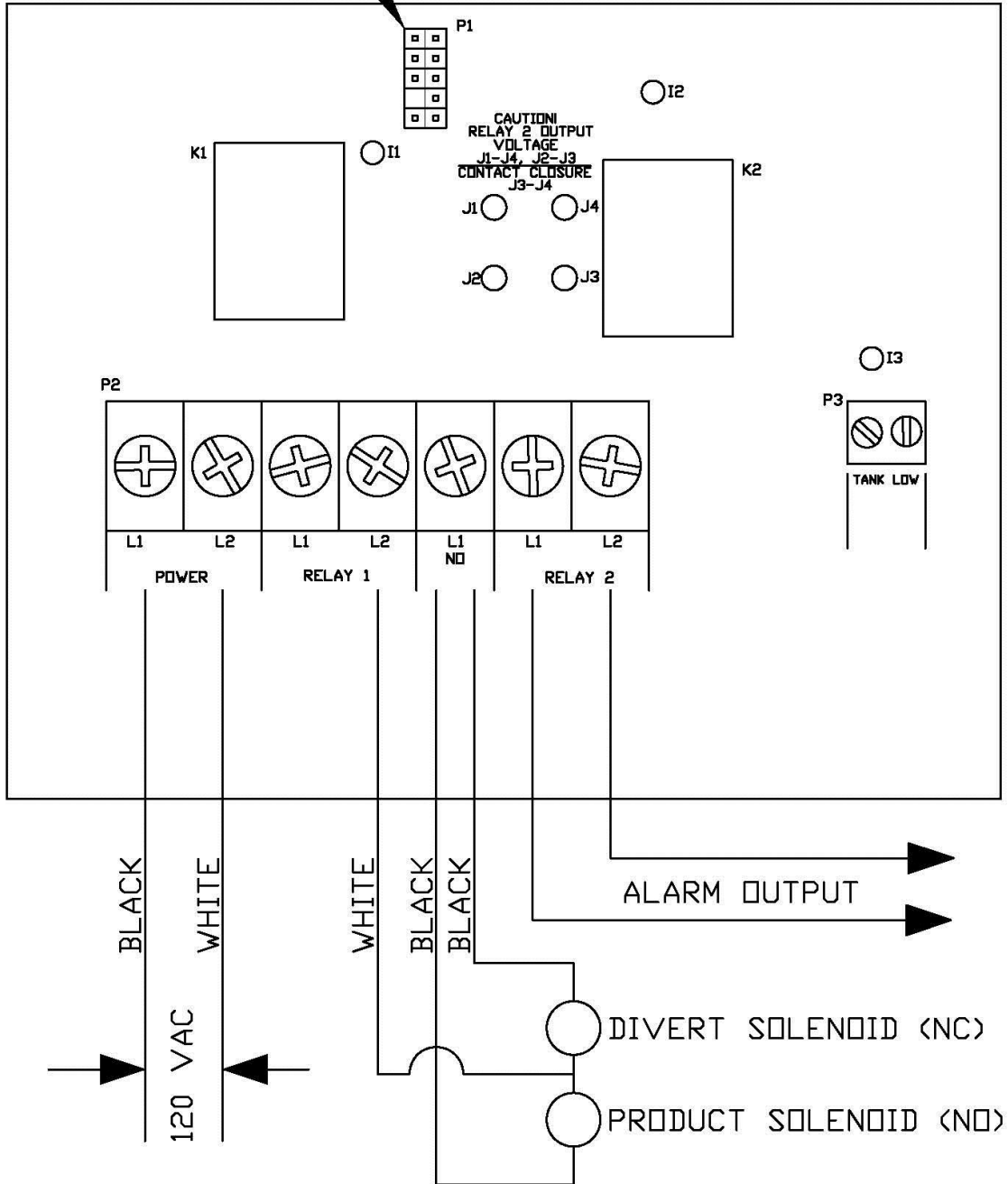

FIGURE 6.2

RIBBON CABLE  
FROM MAIN BOARD  
CONNECTION



**FIGURE 6.3**

## 6.4 STANDARD SETPOINTS

SETPOINT	DESCRIPTION	RANGE	FACTORY SETTING
TDS/Cond Limit	When this value is met or exceeded, the alarm lamp will light and high TDS/Cond will show on the display. To disable, set to 0.	0-999 μS or PPM*	Based on water analysis.
TDS/Cond Delay	When the limit Setpoint is exceeded, no alarm will be given until this time has expired.	0-999 seconds	10
RO Start Delay	The amount of time between the inlet valve opening and the RO pump start.	0-99 Seconds	10
Press Fault Delay	The time a pressure fault must be active before a pressure fault shut down occurs.	0-99 Seconds	10
Auto Reset	When a pressure fault shut down is active, the system will attempt to restart after this delay. If set to 0, system must be manually reset.	0-99 minutes	0
Alarm Silence	If the audible alarm is silenced, after this delay, the alarm will resound. If set to 0, the alarm will remain silenced.	0-99 minutes	3
TF Restart Delay	When a tank full condition clears, the system will restart after this delay.	0-99 sec/min	5
TF Restart	Selects whether the tank full restart delay is in seconds or minutes. 0=seconds, 1=minutes.	0-1	0
TFO Time	The amount of time that a tank full override lasts.	0-15 Minutes	3
Tank Lo Restart	Not Used		
Flush Type	Selects the type of flush. Set to 0 to disable.	0-8	0
Flush Time	The length of time a membrane flush cycle will last when flush is active.	0-99	0

\* μS = microsiemens; PPM = Parts Per Million

SETPOINT	DESCRIPTION	RANGE	FACTORY SETTING
Flush Interval	The interval between flush cycles. Only valid with operation hour, elapsed time or off flush types.	0-99 minutes	0
Flush Mode	Selects if the inlet and RO pump relays operate during flush.	1-4	0
Maximum Hours	If the current operating hours exceed this limit, the operating hours warning will occur. To disable, set to 0.	0-65000 hours	0
Current Hours	Current number of hours of RO system operation.	0-65000 hours	0
Expander Mode	Not Used		
Temp Offset	Allows adjustment of temperature reading by $\pm 5$ °F.	$\pm 5$	0
Temp UOM	Selects display of temperature in °F or °C	0-1	0
Switch Select	Selects if switch inputs are normally open or normally closed.	0-32	0
TDS/Cond UOM	Selects display of water quality in $\mu$ S or PPM <b>NOTE: If this Set point is changed, the unit must be recalibrated.</b>	0-1	0
TDS/Cond Range	Selects range of TDS/Conductivity monitor 0-50, 1-100, 2-250, 3-500, 4-1000, 5-2500, 6-5000. <b>NOTE: If this Set point is changed, the unit must be recalibrated.</b>	0-6	1
C2 Range	Selects range of TDS/Conductivity monitor 0-50, 1-100, 2-250, 3-500, 4-1000, 5-2500, 6-5000. <b>NOTE: If this Set point is changed, the unit must be recalibrated and range components may need to be changed.</b>	0-6	4
C2 Limit	When this value is met or exceeded, the alarm lamp will light and high TDS/Cond will show on the display. To disable, set to 0.		
<p><b>NOTE: If the incoming feed water is greater than 1000 <math>\mu</math>S (i.e. C2 Range is set to 5 or 6), first turn the Write Protect off by moving the Write Protect chip in the controller to the off position. Then change the value of C2 Range to either 5 or 6. Next, remove the resistor in the controller in the R10 position (note that it has not been soldered in place) and place the resistor in the R9 position (also not soldered in place) into the now vacant R10 position. Finally, recalibrate the unit using a conductivity meter.</b></p>			
<p><b>NOTE: If this Setpoint is changed, the unit must be recalibrated and range components may need to be changed.</b></p>			
%Rej	The 2 <sup>nd</sup> TDS/Conductivity is used to monitor 0-1 feed water, programming this set point to 1 allows the % rejection to be displayed.		

## **6.5 TO DISPLAY OR CHANGE SETPOINTS**

**NOTE: Please contact your AmeriWater representative prior to changing set points.**

1. Refer to Figure 6.1 for the location of the keys used to display or change the Setpoints and Figure 6.2 for the location of the write protect jumper, J3. For the unit to be able to accept a change in a Setpoint, the shorting jumper must be in the WRITE PROTECT OFF position (center and left pins).

**NOTE: Setpoints cannot be changed if the write protect jumper is in the ON position.**

2. Use the LEFT and RIGHT ARROW keys to display the Setpoints. Each press of an arrow key will advance the display to the next Setpoint. The Left arrow key starts with the beginning Setpoint and the Right arrow key starts with the last Setpoint.
3. The Up and Down arrow keys are used to increase or decrease the Setpoint value. The value will change by 1 count each time a key is pressed. If the key is pressed and held for >1 second, the Setpoint value will change at a fast rate. When the key is released, the fast rate will be reset. Pressing both the UP and DOWN ARROW keys together will reset the set point value to 0.
4. Pressing the ALARM SILENCE/RESET key at any time will cancel the operation and return the display to the main screen.
5. To accept the new set point value, press the ENTER key.
6. The unit will beep twice if the change is accepted. If the write protect jumper is on, the unit will show WRITE PROTECTED on the display and one long beep will sound.
7. When finished changing Setpoints, the write protect jumper should be placed in the ON position (center and right pins).

# SECTION 7, EXTERNAL WIRE INSTALLATION

## FLOAT LEVEL SWITCHES, PRETREAT LOCKOUT & RO ALARM RELAY CONNECTORS

1. Remove the side entry hood by disengaging the lock and pulling down.
2. Loosen 4 retaining screws from outer shroud and remove inner terminals.
3. Loosen the nut and run the float switch wires through the outer housing.
4. Connect the High Tank float wires to contacts 1 & 6, Low Tank wires to contacts 2 & 7, Pretreatment Lockout wires to contacts 3 & 8 and RO Alarm Relay wires to contacts 4 & 9.
5. Replace the inner terminals into the outer shroud.
6. Tighten the nut, replace the retaining screws and re-install the side entry and engage the lock.

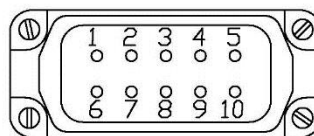
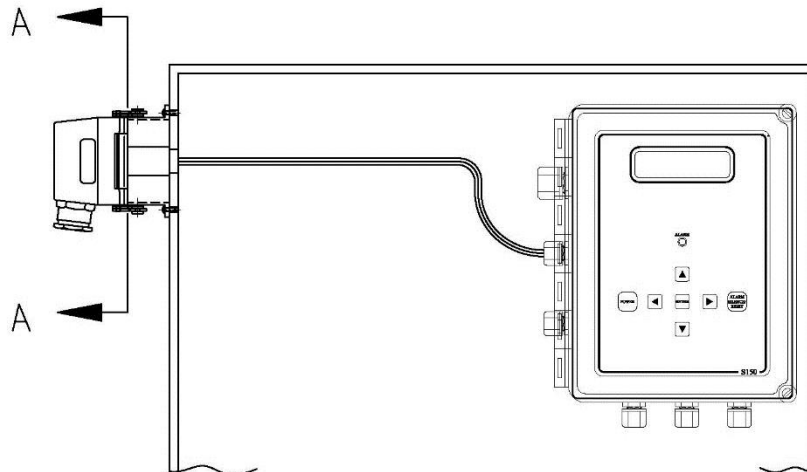

SECTION A-A

4 X SIZE

CONTACTS 1 & 6 ARE FOR FLOAT LEVEL SWITCH, TANK HIGH.  
CONTACTS 2 & 7 ARE FOR FLOAT LEVEL SWITCH, TANK LOW.  
CONTACTS 3 & 8 ARE FOR PRETREATMENT LOCKOUT.  
CONTACTS 4 & 9 ARE FOR RO ALARM RELAY.



## SECTION 8, MAINTENANCE

**WARNING:** If any component of the water treatment system is changed or replaced, the user should conduct appropriate tests to ensure that the revised system meets all standards to which it was initially tested.

**WARNING:** Maintenance shall be performed by qualified personnel only.

### 8.1 MAINTAINING THE SYSTEM

1. AmeriWater has provided a Startup Log for the MRO system. This must be filled out completely each time the system is used. The recorded information may be useful in troubleshooting problems encountered with the MRO. Please see the Startup Log in Section 4.
2. The MRO system will need to be disinfected regularly. The frequency is determined by the usage of the system. If the MRO system is being used every day, it should be disinfected monthly. If the system is being used on an "as needed" basis, with 1 or more days between uses, then it should be "packed" in BioTrol or disinfected before each use.
3. Bacteria and L.A.L. (Limulus Amebocyte Lysate) testing is required monthly and AAMI testing is required annually.
4. Selection of water equipment for dialysis is the responsibility of the dialysis physician (medical director). A water sample should be sent to a lab yearly for a complete AAMI water analysis to ensure that the product water meets AAMI standards.
5. MRO System product water quality is dependent on input water quality. Actual product water quality may vary substantially from the value for specified input water. The expected results for the user's water can only be verified on the basis of analysis of the user's water. If there are variations in the input water or changes detected in the output water, contact AmeriWater immediately.
6. Monitoring of the water bacteriology of the system following installation is the responsibility of the user. Total viable microbial counts shall not exceed the AAMI standard for bacterial colony forming units per milliliter (CFU/ML) or endotoxins measured in endotoxin units (EU). See instructions for proper disinfection of the system in Section 5.
7. The accuracy of the Conductivity display should be verified with a calibrated, hand-held meter at least annually. If the conductivity display is not within 5% of the hand-held meter readings, the controller should be calibrated in accordance to the procedures in Section 6.3. Conductivity may also be verified each time an AAMI analysis is done by noting the conductivity readings when the AAMI sample is drawn and verifying the reading with the AAMI results.

## **8.2 PT401 ANTI-SCALANT**

Smaller AmeriWater MRO products have the PT401 antiscalant system equipped as an option. The larger units, MRO2-5X4 ordinarily have a complete water pre-treatment system (backwashing particulate filter, backwashing carbon filter, and water softener) installed ahead of the MRO. This eliminates the need for the PT401 anti-scalant system within the MRO, and is not a point of discussion in this manual. If your unit has been fitted with a PT401 anti-scalant system due to a water pre-treatment system not being installed ahead of the MRO, refer to the PT401 manual.

## **8.3 MEMBRANE MAINTENANCE INSTRUCTIONS**

### **MEMBRANE REPLACEMENT PROCEDURE:**

Turn off the incoming tap water supply to the MRO and unplug the device from the GFI receptacle. Power down the disconnect for the motor starter. (The following procedure will cause water to leak and spill – This could occur at different times during the procedure - You may get wet.)

1. Place a container under the CHLORAMINE SAMPLE (TEST) PORT and slowly open the port to relieve the pressure on the MRO system.
2. Place a container under the PRODUCT SAMPLE (TEST) PORT on the front panel and open to allow to drain.
3. Open the back panel of cabinet.
4. Press release button on Product Water Manifold (Manifold located near top at back of left wall – looking in back of cabinet) to disconnect product water hose from all membranes being removed.
5. Disconnect the pump feed and reject discharge hose from the membrane being replaced.
6. Remove the unistrut clamps from membrane and pull the membrane assembly from the cabinet.
7. With membrane removed, loosen inlet cap clamp and remove inlet cap from the membrane assembly.
8. Remove used membranes from the housing.
9. Note the serial number of the replacement membrane and indicate this on the outer housing of the membrane assembly with a label maker.
10. Insert the new membrane into the housing inlet.

**NOTE:** You must insert membranes into the inlet end of the housing. Inserting a membrane from the discharge end will damage the membrane's brine seal.

11. Install the membrane assembly by reversing the order of steps 1 through 10.
12. Repeat these steps for each membrane that will need to be replaced.
13. Once all membranes have been replaced, return power to the motor starter, plug the device back into the GFI receptacle and turn on the incoming water supply.

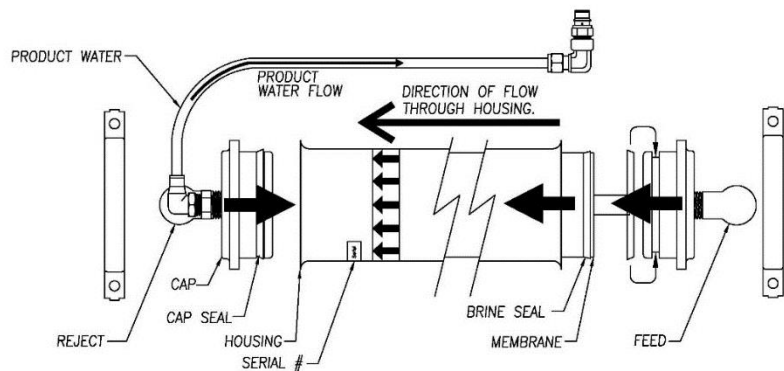

**FIGURE 8.6**

**WARNING:** The Reverse Osmosis (RO) membrane(s) contains a preservative solution to prevent microbiological growth and freezing. Discard all product water for at least two hours of operation before placing the RO back into service.

### Rinse Out Cycle

After the exchange is complete, it is important to put the RO+ through a rinsing out cycle to flush the preservative out of the new membrane.

1. Put the PRODUCT WATER hose at a sink.
2. Turn the Reject Flow Control Knob counterclockwise to give full reject flow. The Pump pressure will be lower than normal during this rinse out cycle.
3. Turn on the RO+ and allow water to run through the system for a minimum of 2 hours to rinse out the preservative. During this operation, verify that the membranes are leak free.
4. Turn the knob on the Reject Flow Control Knob clockwise so that the Product Water flow and Reject Water flow are approximately equal. Allow the RO+ to run about 30 minutes until the conductivity is below the setpoint, and no longer alarming. Turn off the RO+.
5. Disinfect the system per the instructions in section 5.1.
6. Pull an AAMI analysis. The RO+ can be used after disinfection when it begins producing water to the specifications.
7. Reconnect the PRODUCT WATER hose to the dialysis machine.
8. Turn on the RO+. The rinse out cycle is now complete, and the RO+ is ready for use.

**WARNING:** If the product water conductivity does not come out of alarm, do not use the system! Continue rinsing, or call AmeriWater for guidance.

# SECTION 9, TROUBLESHOOTING AND REPAIR

## 9.1 TRUBLESHOOTING CHART

**WARNING:** Only those persons who have read the complete operations manual or who have received authorization from the medical facility director should attempt to troubleshoot and/or repair the MRO system.

To assist you in quickly restoring your system into service, AmeriWater will send your replacement part out immediately and check your bad part when it comes in to verify if it is covered under your equipment warranty.

<b>PROBLEM</b>	<b>POSSIBLE CAUSE</b>	<b>CORRECTIVE ACTION</b>
MRO will not start	MRO not plugged in  Circuit breaker blown  MRO in a FAULT condition	Plug into electrical outlet.  Reset the breaker.  Check MRO controller display for FAULT condition and correct the FAULT.
System has power but no water flow	Feed source not open  Feed pressure < 20 PSI  Incoming hose kinked  Prefilter clogged  Circuit board relay is not operating	Open Incoming Tap Water valve.  Increase pressure to $\geq$ 20 PSI.  Straighten kinks from the INCOMING TAP WATER hose.  Check the prefilter gauges for pressure drop; replace the prefilter if the pressure drop is 10 PSI or greater than initially recorded.  Replace the controller circuit board (Section 9.2)
System has power but no water flow (continued)	Feed solenoid is not operating	Test the solenoid (Section 9.5). Replace the valve if it is defective (see Section 9.6).

<b>PROBLEM</b>	<b>POSSIBLE CAUSE</b>	<b>CORRECTIVE ACTION</b>
Disinfect cycle will not operate when holding the ENTER key	<p>DISINFECT MODE has not been accessed correctly.</p> <p>Circuit board relay not operating in DISINFECT MODE.</p> <p>Disinfect Solenoid Valve not operating</p>	<p>Access DISINFECT MODE (see Section 5.1).</p> <p>Replace the controller circuit board (see Section 9.2).</p> <p>Test solenoid valve (Section 9.5). Replace the valve if it fails (Section 9.6).</p>
Pump making excessive noise	<p>Low pressure or flow rate feeding the MRO</p> <p>Feed solenoid is not operating</p> <p>Pump motor or impeller failing</p>	<p>Check the prefilter outlet gauge PSI (must be <math>\geq 20</math> PSI), and verify that the product flow (flowmeter) <math>&gt; 1</math> GPM.</p> <p>Test the solenoid (Section 9.5). Replace the valve if it is defective (see Section 9.6).</p> <p>Check PUMP PSI GAUGE to verify that it is within operating parameters. Replace the pump assembly if necessary (see Sections 9.3 and 9.4).</p>
Poor quality product water	<p>High Chlorine levels</p> <p>MRO not rinsed thoroughly</p> <p>Reject Flow Meter not properly adjusted.</p> <p>Fouled membrane</p>	<p>Backwash the carbon filter or rebed.</p> <p>Rinse membrane (see Section 8.4).</p> <p>Turn the Reject Flow Meter knob so that the Reject Water flow is equal or slightly greater than the Product Water flow.</p> <p>Exchange membrane. (see Section 8.3).</p> <p>Verify that the conductivity cell accuracy with a known good meter. Follow the calibration procedures in Section 6.5 or replace cell if necessary.</p>

<b>PROBLEM</b>	<b>POSSIBLE CAUSE</b>	<b>CORRECTIVE ACTION</b>
Low product flow rate	Low pressure feeding membrane	Verify that the incoming tap water supply is fully open. The pressure on the prefilter gauges should be $\geq 20$ PSI when the MRO is operating.
	Low pump PSI	Pump should be operating at 175 – 250 PSI.
	Reject GPM flow rate too high	Adjust Reject Water flow rate.
	Excessive PRODUCT line backpressure	Check for restrictions in the PRODUCT WATER FOR DIALYSIS hose. Check the feed pressure gauge on the dialysis machine. If the dialysis machine does not have a pressure gauge, install one inline.
	Low temperature incoming tap water	Consult the Temperature Correction Chart to determine if the flow rate is normal in relation to the feed water temperature.
	Prefilter clogged	Check the prefilter gauges for pressure drop. Replace the prefilter cartridge if the pressure drop is $\geq 10$ PSI.
	Membrane needs replaced	Replace the membrane.
High Bacteria Count	Too long since the last disinfection or the procedure was not performed correctly	Disinfect the MRO following the procedures in Section 5.

## 9.2 CONTROLLER TROUBLESHOOTING

**CAUTION:** Hazardous voltages are present when power is applied to the unit. Care should be taken when troubleshooting any of the input power or output circuits. When disconnecting or connecting any board or accessory, be sure power is unplugged.

Before contacting AmeriWater for technical help, verify the programming of all Setpoints, check the display and check the status of all lights and indicators. The more information available when you contact us, the easier it will be to determine the source of the problem. Standard setpoints, and drawings of the controller and pc boards can be found in Section 6.

PROBLEM	INVESTIGATION	CORRECTIVE ACTION
System Inoperative	<p>Is the yellow CPU active LED blinking?</p> <p>If no, is the green power LED, DS1 Lit?</p> <p>If no, is the fuse OK?</p> <p>If no, replace the fuse.</p> <p>If yes, with a voltmeter, verify power is applied to the power terminals L1 and L2.</p>	<p>If power is applied to the power terminals and the other checks are OK, the pc board is defective and should be replaced.</p> <p>If no power is applied to the board, check the power wiring to the system.</p>
Display Blank	<p>Is the green power LED, DS1 lit?</p> <p>If yes, is the CPU active LED, DS9 blinking?</p> <p>If yes, adjust the display contrast adjustment, R3. Is the display still blank?</p>	<p>If no, refer to the system inoperative section.</p> <p>If no, replace the board.</p> <p>If yes, replace the board.</p>
Inlet Valve Will Not Operate	<p>Is the system in standby?</p> <p>If no, are any shut down conditions active?</p> <p>If no, is the inlet LED, DS8 lit?</p> <p>If yes, with a voltmeter, verify if there is power on the inlet terminals. Is there power?</p>	<p>If no, replace the board.</p> <p>If no, replace the board.</p> <p>If yes, check the valve and wiring.</p>

<b>PROBLEM</b>	<b>INVESTIGATION</b>	<b>CORRECTIVE ACTION</b>
RO Pump Will Not Operate (Cont.)	<p>Is the system in standby?</p> <p>If no, are any shut down conditions active?</p> <p>If no, is the RO LED, DS6 lit?</p> <p>If yes, with a voltmeter, verify if there is power on the RO pump terminals. Is there power?</p>	<p>If no, replace the board.</p> <p>If no, replace the board.</p> <p>If yes, check the pump and wiring.</p>
No or incorrect conductivity reading	<p>Is sensor wired correctly?</p> <p>If yes, is sensor installed inline as shown in the tubing diagram on page 14?</p> <p>If yes, verify correct Conductivity range. Range correct?</p> <p>Does unit calibrate OK?</p> <p>If no, disconnect green and white wires of sensor. Does reading show 0?</p> <p>If yes, reconnect wires and remove sensor from piping and dry. Does reading show 0?</p> <p>If yes, short terminals of cell together. Does reading show '^^^' ?</p>	<p>If no, correct wiring.</p> <p>If no, install correctly.</p> <p>If no, correct range.</p> <p>If yes, calibrate unit.</p> <p>If no, replace board.</p> <p>If no, replace cell.</p> <p>If no, replace board.</p>



### **9.3 PUMP REPAIR**

The following procedures are instructions for removing the pump from the unit. **The MRO5X Series has a 3HP pump with a .75 throttle valve. The repair and removal on the MRO5X is slightly different. The differences are noted in the instructions below where applicable.**

Before replacing the pump, be sure the pump's thermal overload has not tripped. Allow the pump to sit at least 5 minutes to allow it to reset, then try to re-start the pump.

1. Turn off the water supply and the MRO. Unplug the power cord from the electrical outlet and turn off the wall disconnect for the high voltage. If the high voltage cannot be disconnected by a twist-lock plug, make sure there is a "lockout" placed on the handle of the wall disconnect.
2. Open the back panel of the cabinet. Disconnect the pump from the motor starter control box by removing the wires from the connectors
3. Disconnect the feed hose on the pump inlet by loosening the hose clamp on the inlet elbow. **On the MRO5X**, disconnect the feed tube from inlet header by loosening the hose clamp on the hose barb tee.
4. Disconnect the pump discharge hose. Remove the pump PSI tubing by loosening the compression fitting.
5. Remove the clamp securing the pump assembly and remove the assembly from the cabinet.
6. Pull the release tab from the top of the pump to allow the old pump to be removed from the housing. Remove all fittings from the exterior portion of the cap to be re-used on the replacement pump.
7. Allow the pump assembly to fully drain before shipping (warranty replacement only).

### **9.4 INSTALLING A REPLACEMENT PUMP ASSEMBLY**

The following procedures are instructions to install the replacement pump assembly. **The MRO5X Series has a 3HP pump with a .75 throttle valve. The installation on the MRO5X is slightly different. The differences are noted in the instructions below where applicable:**

1. Compare the new pump to the existing to ensure that the voltage is correct.
2. Slide the new pump assembly into the housing taking care that the o-ring does not roll.
3. Secure the cap to the housing with the plastic locking ring previously removed.
4. Clean the threads from the fittings that were previously removed. Apply a suitable thread sealant and install into the cap.

5. Insert the pump assembly and reconnect the pump to the frame using the unistrut clamps.
6. Connect the membrane feed tubing and pump pressure gauge tubing to the pump housing outlet port (at the top), and tighten the ferrule nut. **On the MRO5X**, connect the pump discharge hose to the inlet connection on the 1<sup>st</sup> membrane housing by tightening the fitting, install the throttle valve with hose, tee, nipple and fittings to the outlet of the pump. Connect the feed tube from the inlet header to the hose barb tee by tightening the hose clamp on the hose barb tee.
7. Connect the pump feed hose to the inlet of the pump by tightening the hose clamp.
8. Connect the pump wires to the motor starter box by inserting the wires through the Sealcon fitting on the bottom of the enclosure, and connecting them to the terminal block. Connect the green (ground) wire to the threaded lug in the control box.
9. The pump valve on the MRO5X is factory set, if you need to adjust after pump is replaced, opening the valve will reduce the product flow rate, while closing the valve will increase the product flow rate. As the valve is being adjusted, check product flow rate and pump pressure on the front of the unit. The pump pressure is not to exceed 270psi and the flow rate cannot exceed 6.5gpm or damage to the pump and or over fluxing the membranes will occur.

## **9.5 SOLENOID TEST PROCEDURE**

### **Feed Solenoid**

1. With the MRO Off, turn the Incoming Tap Water supply on. **If there is water flowing to the drain, the solenoid has failed open.**
2. Turn on the MRO, with the Incoming Tap Water supply still on. **If there is no flow to the drain, the solenoid has failed closed.**
3. Use a voltmeter to verify that power is not being supplied to the INLET SOLENOID VALVE terminal when the MRO is off, and that power is being supplied to the terminal when the MRO is on. If the power supply is normal, the solenoid valve is bad. If the power supply is not correct, see Section 9, Controller Troubleshooting.

### **Disinfect Solenoid**

1. Turn off the MRO.
2. Turn the knob on the Reject Water flow meter counterclockwise about 2 – 3 revolutions.
3. Press and hold the LEFT ARROW KEY and press the RIGHT ARROW KEY to access the DISINFECT MODE.
4. Hold in the ENTER KEY until water flows to the drain. **If there is no water flow to the drain, the solenoid has failed closed.**

## **9.6 SOLENOID VALVE REPLACEMENT**

### **For all valves, Feed, Disinfect, or Product Divert Solenoid Valves**

1. Turn off the MRO by pressing the POWER key (the display will show STANDBY), unplug the 120 VAC power cord from the electrical outlet, turn off the wall disconnect, and place a lockout in the disconnect handle.
2. Turn off the incoming tap water supply to the MRO.
3. Open the back panel of the cabinet.
4. Remove the membrane(s) and pump (see Section 9.4).
5. Disconnect the solenoid wiring harness plug from the solenoid valve.
6. Disconnect the hoses/tubing from the solenoid valve.
7. Remove the valve from the MRO cabinet by unbolting it from the cabinet.
8. Remove the hose/tube fittings from the defective valve.
9. Make sure that the flow direction arrow located on the side of the valve is pointing in the correct direction (same as one being replaced).
10. Install per the kit instructions.
11. Reattach the hose/tubing to the corresponding fittings on the valve.
12. Reconnect the wire harness to the valve.
13. Replace the membrane(s), and pump.
14. To verify that the solenoid valve is installed correctly, follow the Solenoid Test Procedures in Section 9.5.

## **SECTION 10, WARRANTY**

This product is covered under the standard AmeriWater warranty policy. For specific terms and conditions, please contact your AmeriWater Sales Representative.

# SECTION 11 SPARE PARTS LISTING

ITEM #	DESCRIPTION	PART NUMBER	ITEM #	DESCRIPTION	PART NUMBER
1	FLOW METER 1-10 GPM	41530612	14b	PUMP, 208V, 3 PH, MRO2X THRU MRO4X	R080-0007
2	VALVED METER 1-10 GPM	41-0024	14c	PUMP, 230V, 3 PH, MRO2X THRU MRO4X	R080-0009
3	SIDE ENTRY HOOD	0167-0014	14d	PUMP, 460V, 3 PH, MRO2X THRU MRO4X	R080-0010
4	BALL VALVE	041003	14e	PUMP, 208V, 3 PH, MRO5X	0180-3208
5	PRESSURE GAUGE 0-100 PSI	43-0012	14f	PUMP, 230V, 3 PH, MRO5X	0180-3230
6	1/2" HB x MPT ELBOW	14520406	15a	MOTOR STARTER 3 PH	60760445
7	3/4" HB x 1/2" MPT ELBOW	14520408	15b	MOTOR STARTER 460V, 3 PH	61-0005
8	3/4" HB x MPT ELBOW	14520410	16	CONDUCTIVITY SENSOR	69446017
9	PAA QUICK DISCONNECT	16-0042	17	0.5" FPT, NC SOLENOID	R59-0002
10	PAA BOTTLE ASSY	0185-0039	18	0.5" FPT, NO SOLENOID	R59-0006
11	0-300 PSI GAUGE	43530714	19	0.75" FPT, NC SOLENOID	R59-0015
12	CONTROLLER ASSEMBLY	R69446010	20	0.75" EJECTOR	40531603
13	MEMBRANE	R22-4040	21	PRESSURE SWITCH	65-0014
14a	PUMP, 220V, 1 PH, MRO2X THRU MRO4X	R080-0008	22	PUMP, 208V, 3 PH, 3HP, MRO5X	R080-0012

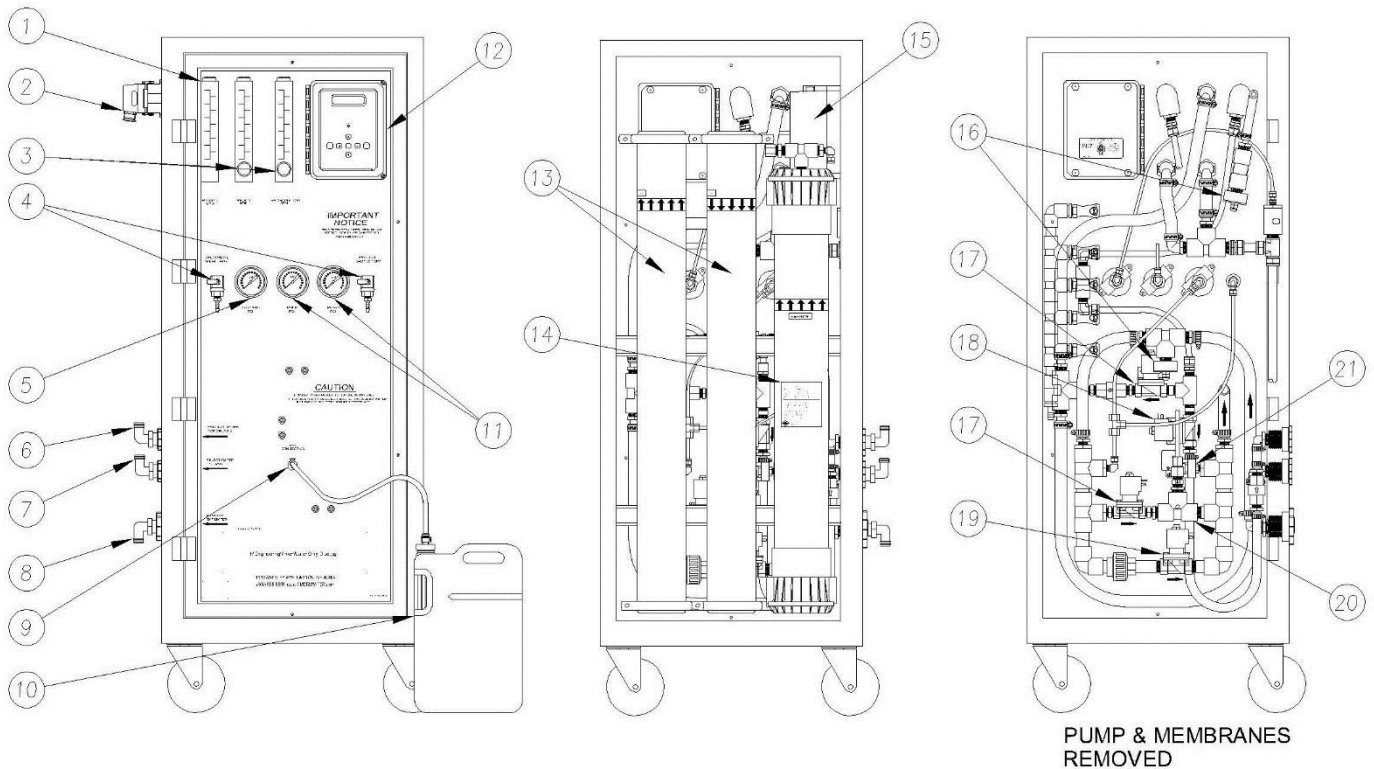

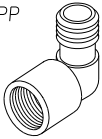
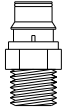
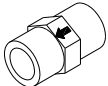
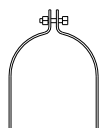
<p>ADPT,STAINLESS STEEL, .25FPT,.25T PN: 10-0024</p> 	<p>FEMALE CON, NPT X TUBE 1/4" PN: 10-L026 3/8" PN: 10-L027</p> 	<p>MALE ELBOW, NPT X TUBE 1/4" PN: 10-L051 1/2" PN: 10-L107</p> 	<p>PLUG IN ELBOW .25 PN: 10-L376 .38 PN: 10-L377 .5 PN: 10-L378</p> 
<p>REPLACEMENT NUTS, SS .25 PN: 10-0026 .75 PN: 10-0035</p> 	<p>REPLACEMENT FERRULES, SS .25 PN: 10-0029 .75 PN: 10-0036</p> <p>FITTING SIDE  NUT SIDE </p> <p>SOLD IN SETS OF 10 ONLY.</p>	<p>ADPT, STAINLESS STEEL, .25MPT, .25T PN: 10-0032 .75MPT, .75T PN: 10-8001</p> 	<p>TEE, BRANCH .75MPTx .75T, STAINLESS STEEL PN:10-8005</p> 
<p>TEE, RUN, .75MPTx .75T, STAINLESS STEEL PN:10-8006</p> 	<p>MALE CON, NPT X TUBE SS .75 NPT X .5 T PN: 10-8007</p> 	<p>BUSHING, SOC X THRD .75 x .25, PVC PN: 041530218 .75 x .5, PVC PN: 041531612 1 X .75 PVC PN: 041530952</p> 	<p>FIP, SOC X THRD .75 PN: 04162075</p> 
<p>TEE, NPT THREAD .5 PP, PN: 046531601 .5 PVC80, PN: 041531509 .75 PP, PN: 046520421 .75 PVC80, PN:041531504</p> 	<p>BUSHING THRD X THRD .5 X .25 SS, PN: 044530212 .75 X .5 PP, PN: 046531845 1 X .5 PP, PN: 046520419</p> 	<p>NIPPLE .5 X CL PP, PN: 046531105 .5 X 2 SS, PN: 044531108 .5 X 4 SS, PN: 044-0014 1 X CL PVC, PN: 041720151 1.25 X CL SS, PN: 044531606</p> 	<p>JACO,CONNECTOR: FPT x TUBE .5 FPT x .38 TUBE PN: 10720812</p> 
<p>HOSES INLET &amp; REJECT 3/4" : 12677130 PRODUCT 1/2": 12677125</p> 	<p>MALE ADAPTER, NPT X HB .5 X .5,PP PN:14520506 .5 X .75, PP PN:14110000 .75 X .75, PP PN:14570115 .75 X .5, PP PN:14520509 .75 X .75, PVC PN:14730014</p> 	<p>MALE ADAPTER ELBOW .5 X .5 PP, PN: 14520406 .5 X .75 PP, PN: 14520408 .75 X .5 PP, PN: 14520409 .75 X .75 PP, PN: 14520410 1 X .75 PP, PN: 14520412</p> 	<p>FEMALE ADAPTER ELBOW .75 NPTx .75 HB, PP PN- 14520411</p> 
<p>HOSE CLAMP STAINLESS 1/2" = PN: 15650050 3/4" = PN: 15650075</p> 	<p>PAA CONNECTION PN: 16-0042</p> 	<p>Q-CON, FEMALE, W/ SHUTOFF PN: 16-0077</p> 	<p>Q-CON, MALE, NO SHUTOFF PN: 16-0078</p> 
<p>CHECK VALVE,.5FPT PN: 55-0010</p> 	<p>STRAIN RELIEF FITTING PN:66510621 3 HOLE BUSHING PN: 66-0041 4 HOLE BUSHING PN: 66-0042</p> 	<p>STRAIN RELIEF ELBOW .5NPT, SPIRAL, BLK PLASTIC PN: 66510619</p> 	<p>INLET PRESSURE SWITCH P/N: R65511105 SET AT 3 PSI</p> 
<p>LINE CORD PN: 66932111</p> 	<p>SOLENOID WIRE HARNESS PN: 66932109</p> 	<p>CLAMP PN: 91730149 MEMBRANES PN: 91730173 PUMP</p> 	<p>CASTER, 5" PN: 94-0009 W/BRAKE PN: 94-0010</p> 
<p>TUBING MEMBRANE AND FLOWMETER ASSEMBLY 3/4": 08-7001</p> 	<p>MALE CON, NPT X TUBE SS .75 NPT X .75 T PN: 10-8003</p> 		

ROUTINE REPLACEMENT ITEMS (NON-DURABLE COMPONENTS)

<b>PART #</b>	<b>DESCRIPTION</b>
0013-0002	O-Ring Kit for 24-0007 Membrane Housing
22-4040	MRO Membrane
95-0006	PERACIDIN DISINFECTANT, 2 QUARTS
95-0007	PERACIDIN DISINFECTANT, 4 QUARTS
97WS20301	Test Strips Water Soft, Water Hardness (6 bottles of 100 strips each)
97HP20401	Test Strips Peracid Test (6 Bottles of 100 Strips each) For Measuring High Range Paracetic Acid
97PX20501	Test Strips Renal Check (6 Bottles of 100 Strips each) For Measuring Residual Peroxide
97PH20901	Test Strips pH (6 Bottles of 100 Strips each) For Measuring pH/Water/Acid,Base/Bicarbonate/Dialysate
97RC22101	WaterCheck RC (6 Bottles of 100 Strips each) For Measuring Residual Chlorine
97CM20201	WaterCheck 2 (6 Bottles of 100 Strips each) For Measuring Low Level Chlorine/Chloramine
LAL	LAL Endotoxin Testing, Exact results in just a few days
AAMI	AAMI Chemical Analysis, Results within one week

\*Call AmeriWater or your AmeriWater distributor for pricing.

## EXPLANATION OF THE 0013-0002 O-RING REPLACEMENT KIT FOR THE 24-0007 MEMBRANE HOUSING

The 24-0007 membrane housing is purchased from (2) different vendors, Pureteck & Axeon. To identify the correct housing being used with your product, reference the pictures below.

The 0013-0002 o-ring kit contains a quantity of (2) of the 24-0029 o-rings and a quantity of (2) of the 24-0028 u-packing seals that are used on the Pureteck membrane housing for the (2) end caps.

Also included in the kit are a quantity of (4) of the 24-0018 o-rings used on the Axeon membrane housing for the (2) end caps. See the drawing below.

